

SHAWNEE STATE UNIVERSITY

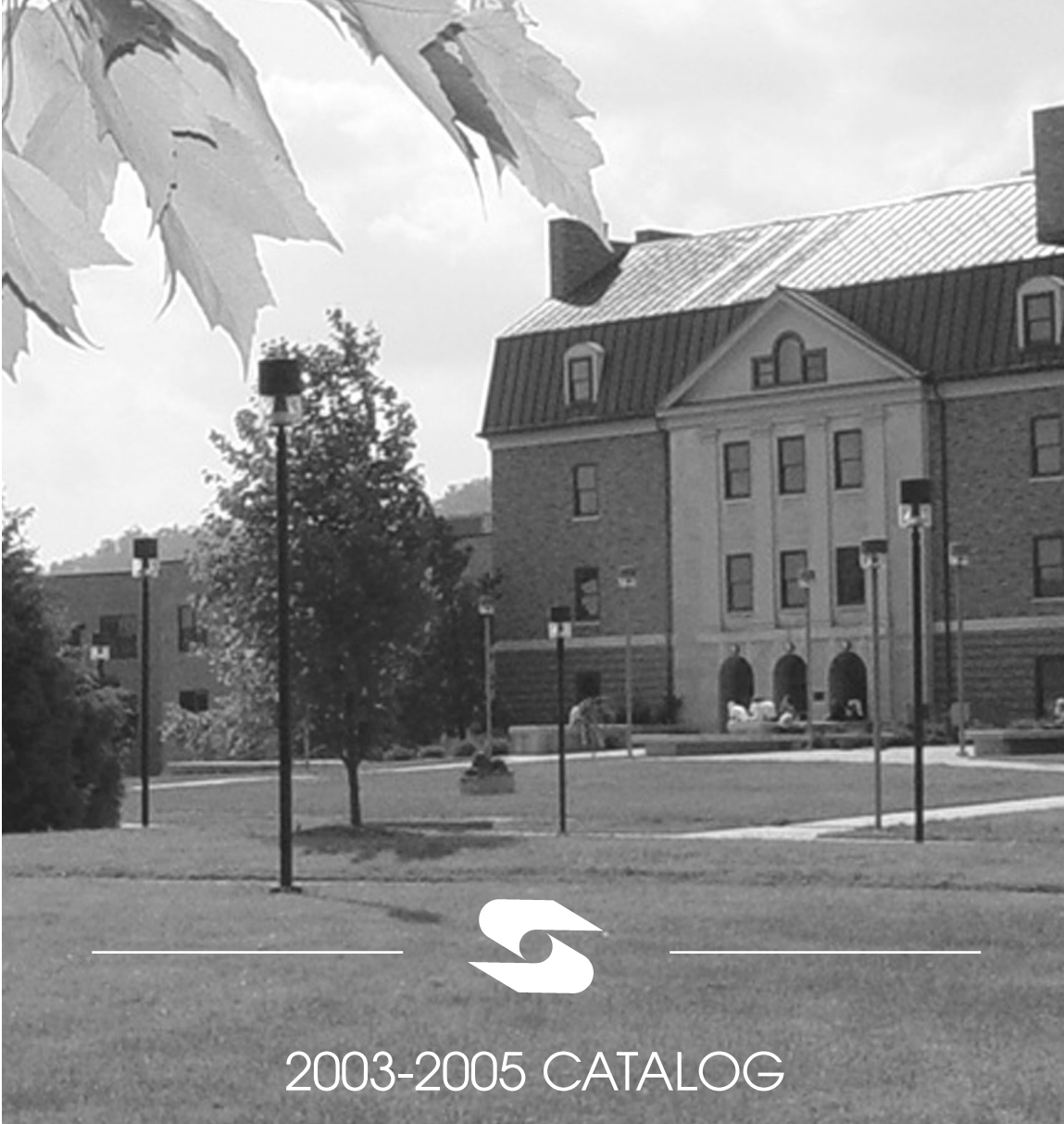

2003-2005 CATALOG

Shawnee State University does not discriminate in admission, access, or treatment in programs and activities or employment policies or practices on the basis of race, creed, sex, color, national or ethnic origin, religion, marital status, age, sexual orientation, Vietnam-era or qualified disabled veteran status, or qualified handicap. Accordingly, Shawnee State University complies with Title VI (34 C.F.R. Part 100) and Title VII of the Civil Rights Act of 1964, Title IX of the Education Amendments of 1972 (34 C.F.R. Part 106), the Age Discrimination in Employment Act of 1967, The Age Discrimination Act of 1975, the Equal Pay Act of 1963, Section 504 of the Rehabilitation Act of 1973 (34 C.F.R. Part 104), the Americans with Disabilities Act of 1990, and other appropriate state and federal statutes, regulations, and/or guidelines as they exist and may be amended from time to time. Inquiries regarding compliance with Title VI, Title IX, and Section 504 may be directed to the Affirmative Action Coordinator, located in the Office of the President, Commons Bldg., Shawnee State University, Portsmouth, OH 45662, telephone 740.354.3205; to the Director, Ohio Civil Rights Commission, 220 Parsons Ave., Columbus, OH 43266; to the Director, Office for Civil Rights, U.S. Department of Education, Region V, 401 S. State St., Chicago, IL 60605; or to the Assistant Secretary for Civil Rights, U.S. Department of Education, Washington, D.C. 20202.

© Shawnee State University, 2003

3	Welcome	58	College of Arts and Sciences
4	How to Reach Us	65	English and Humanities
5	About the University <i>Past and Present • Mission Statement • The Strategic Plan • Accreditations and Approvals</i>	72	Fine, Digital, and Performing Arts
10	Academic Calendar <i>2003 -2004 Academic Calendar • Tentative 2004-2005 Academic Calendar</i>	79	Mathematical Sciences
14	Admission Policies <i>Degree-Seeking High School Graduates • Applicants with the GED • Undeclared Major/Undecided Student • Freshman Studies • Transfer Students • International Students • Non-Degree Students • Campus Tours</i>	86	Natural Sciences
24	Registration Information <i>Registration • Student Success Center • Placement Testing • Orientation</i>	96	Social Sciences
28	Fees and Financial Aid <i>Fees and Expenses • Financial Aid</i>	107	Teacher Education
36	Academic Policies and Programs <i>Academic Integrity • Grading/Awarding of Credit • Catalog Rights • Class Ranking • Incomplete Grades • Administrative Hold • Academic Assessment • Dean's List/President's List • Pass/No-Credit • Credit by Examination • College Level Examination Program • Credit for Military Experiences • Prerequisites • Repeating Coursework • Grade Appeals • Grade Point Average • Academic Probation • Fresh Start • Academic Suspension/Dismissal • Audit (Non-Credit) • Course Credit by Arrangement • Internship Guidelines • Faculty Advising • Faculty Expectations and Responsibilities • Visitors to Class • Bringing Children to or Leaving Children at the University • Adding a Class • Dropping a Class • Withdrawing Completely • Transcripts/Grade Reports • Graduation Requirements • Graduation with Honors • Honors Program • Graduate Center • Center for International Programs and Activities • Academic Support • Developmental Education • Clark Memorial Library</i>	126	College of Professional Studies
46	Student Development <i>Athletics • Bookstore • Children's Learning Center • Counseling • Health Services • Student Activities</i>	130	Business Administration
53	Academic Programs <i>Programs of Study • General Education Program</i>	143	Health Sciences
		165	Industrial and Engineering Technologies
		176	Pre-College Programs <i>BASICS • BEAR CUBS Program • Talent Search • Upward Bound • Upward Bound Math Science Center</i>
		179	University Outreach Services <i>College Tech Prep Ohio South Consortium • Contract and Targeted Industries Training • School-to-Work, Urban/Rural Opportunities Grant • 21st Century Community Learning Centers</i>
		183	Affiliated Organizations <i>Ohio Appalachian Center for Higher Education • Ohio Appalachian Educational Opportunity Center • ROAD:MAP 2005</i>
		185	Course Descriptions
		277	Trustees, Staff, & Faculty
		285	Index
		291	Survey



Message from the President

When you prepare to go on vacation or a business or recreational trip, most likely you will take out the atlas and map out your travel route. You may be one of the many who utilizes services on the World Wide Web for directions to your destination. An accurate roadmap is extremely important to ensure that you reach your travel objective in a timely fashion.

This 2003-2005 edition of the Shawnee State University catalog is your “roadmap” to reaching your academic and career objectives. Each course you take complements others that add up to the route you follow to get to your destination. The courses you take may not mean much individually. Collectively, however, they represent the overall outcome—a two- or four-year degree that prepares you to succeed in whatever field you choose.

Do not lose sight of your overall objective, and do not simply read your “roadmap” once and then stash it in a drawer somewhere. Keep it handy so you reach your “travel” objective in an accurate and timely fashion. The General Education Program and the curriculum that was designed by your academic department give you the solid foundation and background, respectively, to become the best educator, graphic designer, business owner, author, health care professional, engineering technology professional, or other professional that you can possibly become.

Always remain focused. Through hard work, perseverance, and following your “roadmap” closely, you will attain your goals. I wish you the best at Shawnee State University.

Sincerely,

A handwritten signature in cursive script that reads "Rita Rice Morris".

Rita Rice Morris, Ph.D.
President

How to Reach Us

Mailing Address

Shawnee State University
940 Second Street
Portsmouth, Ohio 45662-4344

Telephone Number

740.354.3205
740.351.3205
TTY 740.351.3159

FAX Number

740.351.3416

E-Mail

To_SSU@shawnee.edu

World Wide Web

www.shawnee.edu

Communication with Shawnee State will be easier if your first message is addressed to the people listed below. The telephone numbers listed provide direct access to those offices.

Admission • 351.4SSU
Alumni Relations • 351.3810
Arts and Sciences, College of
• 351.3554
Assessment Office • 351.3583
Athletic Center • 351.3285
Athletics, Intercollegiate and
Intramural • 351.3285
BASICS • 351.3325
Bookstore • 351.3418
Business Administration, Dpt. of
• 351.3215
Business Office (payment of bills)
• 351.3279
Cafeteria • 351.3617
Campus Tours • 351.4778
Career Services • 351.3259
Center for International Programs
• 351.3127

CLEP Testing • 351.3594
Clubs and Organizations • 351.3217
Communications • 351.3810
Counseling and Psychological
Services • 351.3539
Degree Programs, Admission
• 351.4778
Dental Hygiene Clinic • 351.3241
Development • 351.3284
Developmental Education:
English & Humanities • 351.3300
Mathematics • 351.3301
Disability Services • 351.3276
Donations, Gifts, Bequests
• 351.3284
English and Humanities, Dpt. of
• 351.3300
Financial Aid • 351.4AID
Fine, Digital, & Performing Arts,
Dpt. of • 351.3118
General Education Program
• 351.3137
Graduate Center • 351.3177
Greek Council • 351.3541
Health Sciences, Department of
• 351.3225
Housing • 351.3217
Industrial and Engineering
Technologies, Department of
• 351.3224
Institutional Research • 351.3450
International Students • 351.3221
L.E.A.D. (Leadership Development
Program) • 351.3217
Library • 351.3323
Mathematical Sciences, Dpt. of
• 351.3301
Media Services • 351.3319
Millers Analogies Test • 351.3594
Multicultural Student Services
• 351.3553
Natural Sciences, Department of
• 351.3456
Orientation, New Student
• 351.3594
Personnel, Faculty • 351.3260
Personnel, Staff • 351.3420
Placement Testing • 351.3594

Presidential and Trustee Affairs
• 351.3208
Professional Studies, College of
• 351.3270
Provost's Office • 351.3472
Registration • 351.3262
Social Sciences, Department of
• 351.3234
Student Activities • 351.3217
Student Affairs • 351.3280
Student Employment • 351.3213
Student Government Association
• 351.3320
Student Newspaper • 351.3278
Student Programming Board
• 351.3467
Student Success Center • 351.3594
Student Support Services • 351.4777
Talent Search • 351.3436
Teacher Education, Dpt. of
• 351.3451
Title III • 351.3594
Transcripts • 351.3403
Transfer Admission • 351.4778
Tutoring, Supplemental
Instruction, Learning Assistance
• 351.3594
University Advancement
• 351.3171
University Outreach Services
• 351.3274 or 866.672.8778
University Center • 351.3217
Upward Bound • 351.3439
Veterans Coordinator • 351.4441

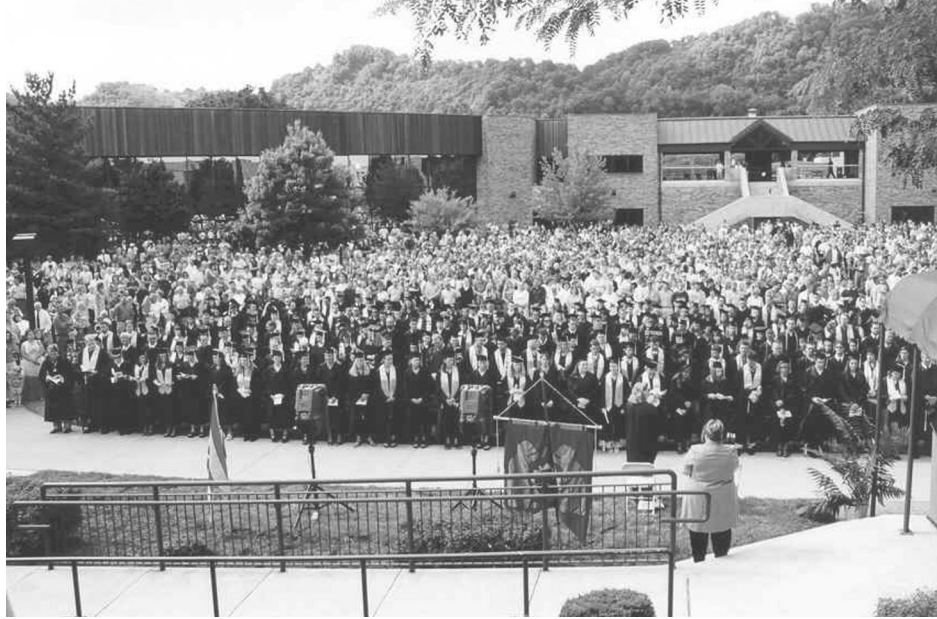

ABOUT THE **UNIVERSITY**



Shawnee State University: Past and Present

In 1986, an act of the Ohio Legislature (put in effect on July 2) created Shawnee State University, from what was formerly a community college. Since then, Shawnee State University—the regional state university of south central Ohio—has continued to incorporate baccalaureate degree programs with its already successful associate degree programs.

Shawnee State offers more than 80 bachelor's and associate degree programs in areas such as the fine, digital, and performing arts; English and humanities; mathematical sciences; natural sciences; social sciences; teacher education; business administration; industrial and engineering technologies; and health sciences. Shawnee State University, the university of opportunity, has one of the lowest tuition rates among Ohio's public universities, and it offers an in-state tuition rate to eligible students in Kentucky. Enrollment at Ohio's newest four-year institution is typically around 3,600.

Shawnee State University's federally funded TRIO programs prepare qualified individuals from disadvantaged backgrounds for programs of post-secondary education. The University features five TRIO programs—Upward Bound, Educational Talent Search, Student Support Services, Educational Opportunity Center, and Upward Bound Math Science—and has made application to begin a sixth program, Veterans Upward Bound.

Shawnee State University is also home to the Ohio Appalachian Center for Higher Education (OACHE), an organization that sponsors projects in 40 partner public school districts and ten member institutions. Its goal is to break down the barriers to access and success in higher education. Twenty-nine Ohio Appalachia counties are in the project area, and OACHE-sponsored projects have been responsible for increasing the college-going rate in the school systems in these counties.

The only public university in Ohio located on the banks of the Ohio River, Shawnee State features a beautifully landscaped campus. Its 26 buildings include the Advanced Technology Center, home of one of only 50 Digistar II planetariums in the

world. Clark Memorial Library offers multimedia and streaming video resources, access to both traditional hard copy and electronic full-text books and articles, a variety of study-space options, and personal assistance to students and faculty. The 102,000 square foot Vern Riffe Center for the Arts features an acoustically superior 1,139 seat Main Theater and is home to both cultural and academic programs. The James A. Rhodes Athletic Center offers a gymnasium that is home to the Shawnee State Bears, weight rooms, racquetball courts, a dance classroom, and a junior Olympic-size swimming pool. Shawnee State's Children's Learning Center serves as a center of learning for area children as well as a lab school for teacher education students at the University.

Shawnee State has a rich tradition of success in athletics. A member of the National Association of Intercollegiate Athletics, the University has participated in 18 national championships in 5 of 11 sponsored sports. The women's basketball team won the NAIA Division II National Championship on March 16, 1999. A member of the American Midwest Conference since 1991, formerly the Mid-Ohio Conference, the Shawnee State Bears have garnered 17 championships in 4 sports.

Engaged in relationships with universities in Germany, China, and Spain, Shawnee State University attracts a growing number of international students while SSU students themselves have the opportunity to travel and study abroad thanks to the Hodgden Travel Fund and the Center for International Programs and Activities (CIPA).

Students come to SSU for many reasons including a low student/teacher ratio, more than \$1.5 million in scholarships, and proven programs that ensure success in the classroom and in finding jobs.

Because of these and many other reasons, more and more individuals are realizing that Shawnee State University is southern Ohio's Dream Machine—where student dreams become careers.

Mission Statement

Shawnee State University—the regional state university of Southern Ohio—prepares students for the changing needs of business, industry, education, and society through its diversified degree programs. Recognizing the importance of knowledge, values, and cultural enrichment, Shawnee State University is committed to providing education that fosters

competence in oral and written communication, scientific and quantitative reasoning, and critical analysis/logical thinking. To enrich the lives of the community, the University provides opportunities for continuing personal and professional development, intellectual discovery, and appreciation for the creative and performing arts.

Goals and Priorities

Dedication to the region. The University's primary focus is the higher education of the region's first-generation college population, offering baccalaureate and associate degrees in traditional academic fields, innovative interdisciplinary curricula, and technical and career-oriented programs. While emphasizing undergraduate education, Shawnee State through its Graduate Center provides the opportunity for other institutions to offer graduate programs on the Portsmouth campus. Currently the University is exploring select graduate programs of its own. Although Shawnee State's programs focus on the interests and needs of the Southern Ohio region, increasing numbers of students from other areas of Ohio, the tri-state, and the nation are enrolling. They are attracted by the quality and distinctiveness of the programs and the appeal of a moderate-cost education offered at a small, public university by a friendly, accessible faculty and staff.

Focus on excellence in teaching. Teaching and learning are Shawnee State's most important functions. Service and scholarship, including creative activities and applied research, are essential parts of this function, especially as they inform teaching. Faculty are evaluated first and foremost on excellence in teaching and second on scholarship and/or service to the University and the community.

Dedication to motivating college attendance and graduation. Shawnee State University serves an ever-increasing number of traditional, nontraditional, and transfer students who find themselves competing for jobs and careers in a global technological society. The vision of larger size for the University is a calling to increase the quality of life of people—through education.

Pledge to developing cooperative relationships. As a state university, SSU fulfills Ohio's public service expectations by meeting state priorities, including the continuing education and training needs of business and industry. Shawnee State is, therefore, a willing partner in cooperative ventures with educational institutions and organizations

that assist in developing the economic, educational, and cultural base of South Central Ohio.

Commitment to increasing quality. Shawnee State University is committed to a process of quality improvement in its desire to serve the changing needs of society, its institutions, and agencies. That improvement is implemented at SSU in several ways: conducting required academic program reviews every five years, meeting the quality standards of professional accrediting agencies, conducting multiple assessments of student learning outcomes, utilizing selective degree program advisory groups of practicing professionals, surveying alumni and employers annually, and applying Total Quality Improvement principles in selected classrooms and student-serving offices.

The Strategic Plan

Theme: Teaching and Learning

Goal: To be widely recognized as an exemplary public university committed to student success and excellence in teaching and learning.

STRATEGIC OPPORTUNITIES:

1. Promote the value of higher education to the community and region.
2. Support and advance effective teaching.
3. Improve student proficiency levels in basic knowledge and skills needed for success in the 21st century, such as oral and written communication, mathematics, and computer skills.
4. Create a "culture of planning" to guide decisions about possible changes in academic programs and services.
5. Sustain academic and student services supporting technical, career-oriented, and professional programs.

Theme: Growth and Development

Goal: To assure the full development of the University through planned enrollment growth and wise investment in educational initiatives.

STRATEGIC OPPORTUNITIES:

1. Increase enrollment.
2. Respond selectively to opportunities for growth and expansion of academic programs.
3. Improve graduation and completion rates of students significantly.

4. Improve institutional procedures through organizational change and continuous attention to student needs and human resource development.

Theme: Community

Goal: To increase opportunities for students, the campus community, and area residents by pursuing joint initiatives with the larger community and by cultivating a shared sense of purpose within the University.

STRATEGIC OPPORTUNITIES:

1. Enhance internal and external communication.
2. Enhance commitment to collective planning and decision making through effective shared governance.
3. Build a more vital campus life.
4. Develop partnerships that involve the University in collaborative activities with other groups and institutions.

Accreditations and Approvals

Shawnee State University is accredited by The Higher Learning Commission and a member of the North Central Association, 30 North LaSalle Street, Suite 2400, Chicago, IL 60602-2504, telephone 312.263.0456 or 800.621.7440. Graduates of the University are awarded baccalaureate and associate degrees and certificates.

In addition, the institution or specific programs are accredited or approved by the following agencies:

Accreditation Council for Occupational Therapy Education

4720 Montgomery Lane
P.O. Box 31220
Bethesda, MD 20824-1220
301.652.2682
www.aota.org

American Dental Association, Commission on Dental Accreditation

211 East Chicago Avenue
Chicago, IL 60611
312.440.2500
www.ada.org

Association of Collegiate Business Schools and Programs

7007 College Boulevard, Suite 420
Overland Park, Kansas 66211
913.339.9356
www.acbsp.org

Committee on Accreditation for Respiratory Care (CoARC)

1248 Harwood Road
Bedford, TX 76021-4244
800.874.5615

Commission on Accreditation in Physical Therapy Education, American Physical Therapy Association

1111 North Fairfax Street
Alexandria, VA 22314-1488
703.706.3245
703.684.2782
www.apta.org

Commission on Accreditation of Allied Health Education Programs (CAAHEP)

35 East Wacker Drive, Suite 1970
Chicago, IL 60601
312.553.9355
www.caahep.org

Joint Review Committee on Education in Radiologic Technology

20 North Wacker Drive, Suite 900
Chicago, IL 60606-2901
312.704.5300

National Accrediting Agency for Clinical Laboratory Sciences

8410 West Bryn Avenue, Suite 670
Chicago, IL 60631-3415
773.714.8880
www.nacls.org

National Council for Accreditation of Teacher Education (NCATE)

2010 Massachusetts Ave. NW, Suite 500
Washington, DC 20036-1023
202.466.7946 • Fax: 202.296.6620
www.ncate.org

National League for Nursing Accrediting**Commission, Inc. (NLNAC)**

61 Broadway, 33rd Floor
New York City, NY 10006
800.669.1656 x153
www.nlnac.org

Ohio Board of Nursing

17 South High Street, Suite 400
Columbus, OH 43215-3413
614.466.3947
www.state.oh.us/nur/

Ohio Board of Regents

30 East Broad Street
36th Floor
Columbus, OH 43266-0417
614.466.6000

**Ohio Department of Public Safety, Division of
Emergency Medical Services (EMT-B and
Paramedic Training Programs)**

1970 West Broad Street
P.O. Box 182073
Columbus, OH 43218
614.466.3250
www.state.oh.us/odps

**State of Ohio, Board of Examiners of Nursing
Home Administrators**

246 North High Street
Columbus, OH 43216
614.466.5714

State of Ohio, Department of Education

65 South Front Street
Columbus, OH 43216-4183
614.466.4838

**State of Ohio, Department of Education,
Division of Vocational Education**

65 South Front Street, Room 910
Columbus, OH 43215-4183
614.466.2901

United States Department of Education

400 Maryland Avenue, SW
Washington, DC 20202-0498
800.U.S.A.LEARN (800.872.5327)

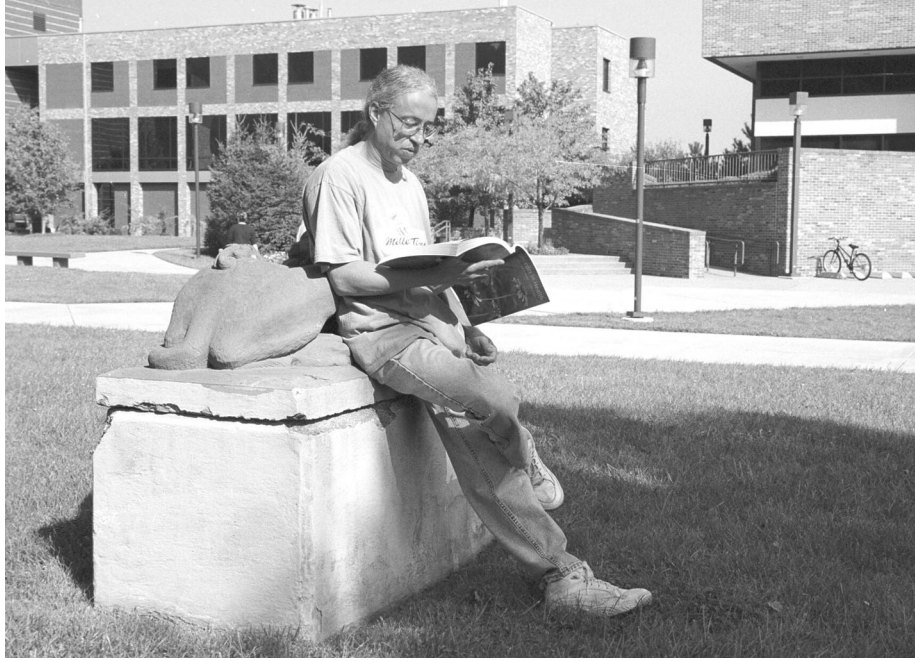

ACADEMIC
CALENDAR



2003-2004 Academic Calendar

Please note the 2003-2004 Academic Calendar as approved by the SSU Board of Trustees on April 17, 2003. The calendar is subject to change.

Summer Quarter, 2003

May 5	Advance registration opens for summer quarter
June 23	Late registration for summer qtr.; First day of summer quarter — classes begin (full summer quarter and first five-week term)
June 25	Last day to add a class (first five-week term)
June 27	Last day for 100% refund upon complete withdrawal (all summer terms); Last day to apply for pass/no-credit (first five-week term); Last day to add a class (full summer term)
July 4	Independence Day Holiday — University closed
July 7	Last day to apply for pass/no-credit (full summer term); Last day to apply for non-credit (first five-week term)
July 17	Last day to drop a class (first five-week term)
July 25	Last day of first five-week term
July 21-26	Final Exams (first five-week term) <i>Final exams scheduled for last class session of this week</i>
July 28	First day of second five-week term
July 29	Grades due in Office of the Registrar by noon (first five-week term)
July 30	Last day to add a class (second five-week term)
August 1	Last day to apply for summer quarter graduation
August 4	Last day to apply for pass/no-credit (second five-week term)

August 11	Last day to apply for non-credit (full summer quarter); Last day to drop a class (full summer quarter)
August 21	Last day to drop a class (second five-week term)
August 25	Last day to apply for non-credit (second five-week term)
August 25-30	Final Exams (second five-week term and full summer term) <i>Final exams scheduled for last class session of this week</i>
August 30	Last day of quarter (full summer term and second five-week term)
September 3	Grades due in Office of the Registrar by noon (full summer qtr. and second five-week term)

Fall Quarter, 2003

May 8	Advance registration opens for fall quarter
September 1	Labor Day — University closed
September 8	Late registration for fall quarter; First day of fall quarter — classes begin
September 12	Last day for 100% refund upon complete withdrawal from full quarter; Last day to add a class
September 19	Last day to apply for pass/no-credit
October 1	Last day to apply for fall quarter graduation
October 6	Yom Kippur — University open
October 13	Columbus Day — Univ. open; Last day to apply for non-credit
October 27	Last day to drop a class
November 3	Advance registration opens for winter quarter
November 11	Veteran's Day Observed — University closed
November 15	Last day of fall quarter
Nov. 17-22	Final Exams
November 26	Grades due in Office of the Registrar by noon
November 27	Thanksgiving Day — University closed
November 28	Thanksgiving Holiday — University closed (in lieu of Columbus Day)
December 25	Christmas Day — Univ. closed
December 26	Christmas Holiday — University closed (in lieu of President's Day)

Winter Quarter, 2004

November 3	Advance registration opens for winter quarter
January 1	New Year's Day — Univ. closed
January 5	First day of winter quarter — classes begin;
	Late registration for winter quarter
January 9	Last day for 100% refund upon complete withdrawal from winter quarter;
	Last day to apply for winter quarter graduation;
	Last day to add a class
January 19	Martin Luther King, Jr. Day — University closed
January 20	Last day to apply for pass/no-credit
February 16	President's Day — Univ. open
February 18	Advance registration for spring quarter opens
February 23	Last day to drop a class;
	Last day to apply for non-credit
March 13	Last day of winter quarter
March 15-20	Final Exams
March 22-26	Spring Break
March 23	Grades due in Office of the Registrar by noon

Spring Quarter, 2004

January 31	Last day to apply for spring qtr. graduation (and participate in June commencement)
February 18	Advance registration opens for spring quarter
March 29	First day of spring quarter — classes begin;
	Late registration for spring qtr.;
	Last day for 100% refund upon complete withdrawal from spring quarter
April 2	Last day to add a class
April 12	Last day to apply for pass/no-credit
May 3	Advance registration opens for summer quarter
May 10	Advance registration opens for fall quarter
May 14	Last day to apply for non-credit
May 18	Last day to drop a class
May 31	Memorial Day — Univ. closed
June 5	Last day of spring quarter
June 7-11	Final exams
June 12	Commencement
June 15	Grades due in Office of the Registrar by noon

**Tentative
2004-2005
Academic
Calendar**

The following calendar for the 2004-2005 academic year is tentative and subject to change.

Summer Quarter, 2004

May 3	Advance registration opens for summer quarter
June 21	First day of summer quarter — classes begin (full summer term and first five-week term)
June 23	Last day to add a class (first five-week term);
	Last day to apply for pass/no-credit (first five-week term)
June 25	Last day for 100% refund upon complete withdrawal (all summer terms);
	Last day to add a class (full summer term)
July 2	Last day to apply for pass/no-credit (full summer term)
July 5	Independence Day Holiday Observed — University closed
July 14	Last day to apply for non-credit (first five-week term)
July 22	Last day to drop a class (first five-week term)
July 23	Last day of first five-week term
July 19-23	Final Exams (first five-week term)
	<i>Final exams scheduled for last class session of this week</i>
July 26	First day of second five-week term
July 28	Grades due in Office of the Registrar by noon (first five-week term);
	Last day to add a class (second five-week term)
July 30	Last day to apply for summer quarter graduation
August 2	Last day to apply for pass/no-credit (second five-week term)

August 9	Last day to apply for non-credit (full summer term); Last day to drop a class (full summer term)
August 17	Last day to apply for non-credit (second five-week term)
August 19	Last day to drop a class (second five-week term)
August 27	Last day of quarter (full summer term and second five-week term)
August 23-27	Final Exams <i>Final exams scheduled last class session of this week</i>
September 1	Grades due in Office of the Registrar by noon (full summer term and second five-week term)

Fall Quarter, 2004

May 10	Advance registration opens for fall quarter
September 6	Labor Day Holiday — University closed
September 8	First day of fall quarter — classes begin
September 14	Last day for 100% refund upon complete withdrawal from fall quarter; Last day to add a class
September 21	Last day to apply for pass/no-credit
September 25	Yom Kippur — University open
October 1	Last day to apply for fall quarter graduation
October 11	Columbus Day — Univ. open
October 26	Last day to apply for non-credit
October 27	Last day to drop a class
November 1	Advance registration opens for winter quarter
November 11	Veteran's Day Observed — University closed
November 17	Last day of fall quarter
Nov. 18-24	Final Exams
November 25	Thanksgiving Day — Univ. closed
November 26	Thanksgiving Holiday — Univ. closed (in lieu of Columbus Day)
December 1	Grades due in Office of the Registrar by noon
December 23	Christmas Holiday Observed — University closed
December 24	Christmas Holiday — University closed (in lieu of President's Day)

Winter Quarter, 2005

November 1	Advance registration opens for winter quarter
December 31	New Year's Day Observed — University closed
January 3	First day of winter quarter — classes begin;
January 7	Last day for 100% refund upon complete withdrawal from winter quarter; Last day to apply for winter quarter graduation; Last day to add a class
January 17	Martin Luther King, Jr. Day — University closed
January 18	Last day to apply for pass/no-credit
February 21	Last day to apply for non-credit; Last day to drop a class; President's Day — Univ. open
February 23	Advance registration opens for spring quarter
March 12	Last day of winter quarter
March 14-19	Final Exams
March 21-26	Spring Break
March 21	Grades due in Office of the Registrar by noon

Spring Quarter, 2005

January 31	Last day to apply for spring qtr. graduation (and participate in June commencement)
February 23	Advance registration opens for spring quarter
March 28	First day of spring quarter — classes begin
April 1	Last day for 100% refund upon complete withdrawal from spring quarter; Last day to add a class
April 11	Last day to apply for pass/no-credit
May 2	Advance registration opens for summer quarter
May 13	Last day to apply for non-credit
May 16	Advance registration opens for fall quarter
May 17	Last day to drop a class
May 30	Memorial Day — Univ. closed
June 4	Last day of spring quarter
June 6-11	Final exams
June 11	Commencement
June 15	Grades due in Office of the Registrar by noon



ADMISSION

POLICIES

Admission to the University

Admission to degree programs at Shawnee State University is open to graduates who hold a state-approved diploma from state chartered or regionally accredited high schools and to students who have earned high school equivalency through the General Education Development (GED) program. However, admission to the University does not guarantee admission to specific programs of study. If you intend to apply for admission to a health science program in the College of Professional Studies, you should refer to the appropriate section of this catalog for specific admission requirements.

Admission to students not seeking a degree at Shawnee State University is also open.

You may request an application for admission to the University by contacting the Office of Admission, or you may complete and submit the application form on-line via the SSU home page at www.shawnee.edu.

There are varying additional requirements for students in different categories, including recent high school graduates, transfer students, special non-degree students, transient students, international students, and eligible students who are still attending high school. Requirements for each are discussed in the following sections.

It is recommended that the high school background of the entering freshman pursuing a degree include:

- 4 units English
- 3 units mathematics (algebra 1 and 2, geometry)
- 3 units social studies
- 3 units science
- 2 units foreign language
- 1 unit visual, performing arts (drama, music, art)

These courses are recommendations, not requirements. However, if you have a deficiency in English or mathematics, you will be required to take developmental courses prior to attempting college level work.

You must apply to the University prior to applying to a health science program. A separate health science application form is available in the Office of Admission.

ACT/SAT

All students pursuing the four-year baccalaureate or two-year associate degrees or the one-year certificate are required to have scores from the American College Test (ACT) or Scholastic Aptitude Test (SAT) forwarded to Shawnee State University. Only applicants who are 21 years of age or older, as of the first day of their first quarter of enrollment, are exempt from providing ACT or SAT scores.

Although Shawnee State has an open admission policy and does not use the ACT or SAT for determining admission to the University, it does require results of these tests for use in advisement and placement. Students who have not yet taken the ACT or SAT may contact the Shawnee State University Admission Office for information about future ACT test dates. Applicants who have not taken the ACT or SAT will be accepted as “provisional students” but must take the exam during the initial quarter of enrollment.

Degree-Seeking High School Graduates

High school graduates who have been awarded a state-approved diploma are required to submit a final, official transcript of academic work to Shawnee State University. Students may send a high school transcript request form (which is attached to the application) or a written request to the high school requesting an official transcript to be forwarded directly to the University.

Transcripts may be mailed directly from the high school to the following address: Office of Admission, Shawnee State University, 940 Second Street, Portsmouth, Ohio 45662-4344. Applicants may also hand-carry the transcript in an envelope sealed with a guidance counselor’s signature. Guidance counselors or high school officials may send transcripts via FAX to 740.351.3111 if accompanied by a signed transmittal form or by electronic transfer. The University reserves the right to verify the final, official authenticity of any student’s transcript. Any transcript document found to be fraudulent becomes the student’s responsibility and the University reserves the right to withdraw admission acknowledgement and/or approval of acceptance.

Advanced Placement

You may be awarded college credit for satisfactory performance on certain proficiency examinations. Each May, participating high schools provide their students with an opportunity to take examinations in a variety of subject areas through the Advanced Placement Program (APTM), sponsored by the College Board and administered by Educational Testing Service (ETS). Students who achieve a grade of 3 or above may receive college credit on the basis of these examinations. Credit given through the AP program does not apply toward the residency requirement for graduation.

In addition, Shawnee State University recognizes that some courses completed in high school or vocational school may be equivalent to some entry-level coursework at Shawnee State. In order to avoid repetition of such courses and to encourage advanced study in the respective disciplines, Shawnee State has entered into “Articulation Agreements” with high schools, vocational schools, and school districts. This allows the award of advanced placement credit for certain coursework completed at the high school where articulation agreements are in place. Such credit waives your course requirement. A more advanced class must be completed to replace the waived course.

Please contact the registrar for information concerning eligibility for credit through advanced placement.

Applicants with the GED

Students who have successfully completed the GED may use the special GED transcript request form (available in the admission office) to have official GED transcripts sent to the University or they may request official transcripts directly from the State GED Office, Ohio Department of Education, 25 South Front Street, Room 210, Columbus, Ohio 43215 or State GED Office, Kentucky Department of Education, Frankfort, Kentucky 40601. If you obtained your GED in another state, please contact the respective state department directly.

Transcripts should be mailed to the following address: Office of Admission, Shawnee State University, 940 Second Street, Portsmouth, Ohio 45662-4344. Transcripts must be received directly from the State GED Office.

If the University is not in receipt of your GED transcript, you may only register for classes as a special non-degree student and are ineligible for financial aid awards.

Undeclared Major/ Undecided Student

If you intend to pursue a degree but are undecided about a major, you may remain “undeclared” until you earn your first 45 quarter hours of credit. At the completion of 45 hours, you are required to declare a major or you are prohibited from registering for classes. The Student Success Center will assist you with this process. Please see Freshman Studies below.

Freshman Studies

All new degree seeking students are admitted to the Freshman Studies Program. By the end of the 45th credit hour attempted, students must move into academic major areas as follows:

1. Score at the collegiate level on the required Shawnee State University placement test(s). ACT or SAT scores may be used to satisfy placement test requirements as stated in this catalog.

and

Declare an academic major or be accepted into a selective program.

OR

2. Satisfactorily complete prescribed developmental education courses if placement test scores are not at the collegiate level.

and

Declare an academic major or be accepted into a selective program.

The Freshman Studies Program has two goals:

- To prepare students to meet the academic standards of the faculty.
- To help students select the appropriate degree program that leads toward graduation.

Transfer Students

Students who have attended other regionally accredited colleges or universities may transfer to Shawnee State University provided they were in good academic standing at the institution attended most recently. In addition to the application for admission and high school transcript, you are required to provide an official transcript from each college or university previously attended. **College transcripts must be received directly from those institutions. Photocopies, fax, and hand-carried transcripts are not accepted.** You may be admitted as a “provisional student” until such time as the official transcripts are received from all previous colleges.

Credits applicable to the curriculum for which you are applying which were earned at regionally accredited colleges or universities are accepted at the time of admission. Generally, courses completed with a grade of C or better are eligible for transfer. Under certain circumstances, a D may be transferable. See the registrar for further information. The credit hours transferred do not become a part of the grade point average at Shawnee State University.

To receive transfer credit, you must file an official transcript of previous college work. You must earn a minimum of 30 credit hours at Shawnee State University to be considered for the award of an associate degree and a minimum of 45 credit hours to be considered for the award of a baccalaureate degree.

If you have attended non-regionally accredited colleges or universities, you may transfer to Shawnee State University provided you meet all admission standards applicable to other transfer students. Credits applicable to the curriculum for which you are applying which were earned at non-regionally accredited institutions will be considered for acceptance as transfer credit if:

- You have completed the associate degree at that institution, and
- You validate the award of credit by completing, with a grade of C or better, a planned program of courses totaling a minimum of 30 credit hours applicable to a four-year curriculum as approved by the registrar. For students transferring credit from non-regionally accredited colleges or universities, a maximum of 90 quarter hours will be considered for transfer.

State Policy On Articulation and Transfer

Institutional Transfer. The Ohio Board of Regents, following the directive of the Ohio General Assembly, has developed a statewide policy to facilitate movement of students and transfer credits from one Ohio public college or university to another. The purpose of the State Policy is to avoid duplication of course requirements and to enhance student mobility throughout Ohio’s higher education system. Since independent colleges and universities in Ohio may or may not be participating in the transfer policy, students interested in transferring to an independent institution are encouraged to check with the college or university of their choice regarding transfer agreements.

Transfer Module. The Ohio Board of Regents’ Transfer and Articulation Policy established the Transfer Module, which is a specific subset or the entire set of a college or university’s general education requirements. The Transfer Module contains 54-60 quarter hours or 36-40 semester hours of specified course credits in English composition, mathematics, fine arts, humanities, social science, behavioral science, natural science, physical science, and interdisciplinary coursework.

A transfer module completed at one college or university will automatically meet the requirements of the transfer module at the receiving institution, once the student is accepted. Students may be required, however, to meet additional general education requirements that are not included in the Transfer Module.

Conditions for Transfer Admission. Students meeting the requirements of the Transfer Module are subject to the following conditions:

1. The policy encourages receiving institutions to give preferential consideration for admission to students who complete the Transfer Module and either the associate of arts or the associate of science degrees. These students will be able to transfer all courses in which they received a passing grade of D or better. Students must have an overall grade point average of 2.0 to be given credit for the Transfer Module.
2. The policy also encourages receiving institutions to give preferential consideration for admission to students who complete the Transfer Module with a grade of C or better in each course and 90 quarter hours or 60 semester hours.

Students must have an overall grade point average of 2.0 to be given credit for the Transfer Module and only courses in which a C or better has been earned will transfer.

3. The policy encourages receiving institutions to admit, on a non-preferential consideration basis, students who complete the Transfer Module with a grade of C or better in each course and less than 90 quarter hours or 60 semester hours. These students will be able to transfer all courses in which they received a grade of C or better.

Admission to a given institution, however, does not guarantee that a transfer student will be automatically admitted to all majors, minors, or fields of concentration at that institution. Once admitted, transfer students shall be subject to the same regulations governing applicability of catalog requirements as all other students. Furthermore, transfer students shall be accorded the same class standing and other privileges as native students on the basis of the number of credits earned. All residency requirements must be successfully completed at the receiving institution prior to the granting of a degree.

Responsibilities of Students. In order to facilitate transfer with maximum applicability of transfer credit, prospective transfer students should plan a course of study that will meet the requirements of a degree program at the receiving institution. Specifically, you should identify early in your collegiate studies an institution and major to which you desire to transfer. Furthermore, you should determine if there are language requirements or any special course requirements that can be met during the freshman or sophomore year. This will enable you to plan and pursue a course of study that will articulate with the receiving institution's major. You are encouraged to seek further information regarding transfer from both your advisor and the college or university to which you plan to transfer.

Appeals Process. A multi-level, broad based appeal process is required to be in place at each institution. A student disagreeing with the application of transfer credit by the receiving institution shall be informed of the right to appeal the decision and the process for filing the appeal. Each institution shall make available to students the appeal process for that specific college or university.

If a transfer student's appeal is denied by the institution after all appeal levels within the

institution have been exhausted, the institution shall advise the student in writing of the availability and process of appeal to the state level Articulation and Transfer Appeals Review Committee.

The Appeals Review Committee shall review and recommend to institutions the resolution of individual cases of appeal from transfer students who have exhausted all local appeal mechanisms concerning applicability of transfer credits at receiving institutions.

Appeal Procedure Regarding Transfer Credit Applicability

Historical Context. On November 16, 1990, the Ohio Board of Regents passed a resolution mandating that public institutions of higher education establish a multilevel appeal procedure to be followed by students dissatisfied with the applicability of transferred credit. The following multilevel appeal procedure at Shawnee State University is designed to meet the needs of these students and to comply with the Ohio Board of Regents' mandate.

Acceptance of Transfer Credit. Transfer credit is awarded and posted to your Shawnee State University transcript in accordance with accepted national and state standards. Generally, all courses satisfactorily completed at regionally accredited institutions are transferable. The Office of the Registrar is responsible for posting this credit to your transcript.

Applicability of Transfer Credit. After transfer credit has been posted to your transcript, the Office of the Registrar posts the courses to your Degree Audit and provides you with a copy of the audit.

Multilevel Appeals Procedure. State mandate requires that you be notified of your right to appeal a transfer credit applicability decision. You must file your written appeal within ninety days following receipt of your Degree Audit. The University must respond to your appeal within thirty days of receipt of the appeal, at each appeal level. The appeal levels are defined below.

Level 1

You meet with the dean of the college in which you are enrolled to discuss the course(s) in question. If both the dean and you are in agreement that a change in applicability is desirable, the dean reports the necessary change with rationale to the registrar.

Shawnee State University Transfer Module (TM)

Field	I. General Education Requirements Needed to Meet Minimum Required Hours in Each Category	II. Additional General Education Requirements to Complete TM	III. Additional General Education Requirements Beyond the TM for Graduation at SSU
English minimum 6 qtr. hours	ENGL 111S (4) ENGL 115S (4)	ENGL 112S (4)	
Mathematics minimum 3 qtr. hours	One of the following: MATH 110S (4) MATH 201 (4) MATH 131 (4) MATH 220 (4) MATH 170 (4) MATH 250 (4) MATH 190 (4)	MATH 132 (4) MATH 202 (4)	
Arts/Humanities minimum 9 qtr. hours	One of the following: IDST 225S (4) PHIL 200 (4) IDST 226S (4) and two of the following: ARTH 101 (4) MUSI 120 (4) ENGL 275 (4) MUSI 220 (4) IDST 227S (4) THAR 100 (4)	ARTH 261 (4) MUSI 221 (3) ARTH 262 (4) MUSI 222 (3) ENGL 200 (4) MUSI 223 (3) ENGL 211 (4) PHIL 105 (4) ENGL 212 (4) PHIL 200 (4)	
Social Science minimum 9 qtr. hours	One of the following: ANTH 250 (4) SOCI 101 (4) GEOG 130 (4) SOSC 110S (4) and two of the following: ANTH 101 (4) HIST 111 (4) ECON 202 (4) HIST 112 (4) GEOG 125 (4) HIST 113 (4) GOVT 101 (4) PSYC 101 (4)	ECON 201 (4) HIST 203 (4) GEOG 201 (4) PSYC 151 (4) GOVT 240 (4) PSYC 273 (4) GOVT 250 (4) SOCI 201 (4) HIST 201 (4) SOCI 205 (4) HIST 202 (4)	
Natural Sciences minimum 9 qtr. hours	Select at least 9 hours from the following courses: BIOL 151 (5) GEOL 111 (4) BIOL 162 (5) GEOL 112 (4) BIOL 202 (5) GEOL 201 (4) BIOL 203 (5) PHYS 201 (4) CHEM 121 (4) PHYS 202 (4) CHEM 122 (4) PHYS 203 (4) CHEM 141 (5) PHYS 210 (4) CHEM 142 (5) PHYS 211 (4) CHEM 143 (5) PHYS 212 (4) CHEM 200 (4) PHYS 213 (4) Note: Credit is not allowed for both CHEM 121/122 and CHEM 141/142 series.	GEOL 202 (4) NTSC 240 (4)	
Interdisciplinary up to 9 qtr. hours	NTSC 110S (4) may substitute for a natural science course in column I (above).		
Subtotal minimum 36 qtr. hours	45-48 qtr. hours	9-12 qtr. hours	IDST 490S (4) and one of the following: PHIL 320S (4) PHIL 331 (4) PHIL 330 (4) ROCI 485S (4)
Total	54 - 60 qtr. hours		

If the dean determines that an applicability change is not warranted, the dean notifies you, the Transfer Credit Appeals Committee chair, and the provost regarding the decision and the rationale.

Level 2

If you and the dean are unable to reach a mutually agreeable resolution, you present your case before the Transfer Credit Appeals Committee. The Transfer Credit Appeals Committee is charged with reviewing the manner in which transfer credit has been applied to your degree program when you and the appropriate dean are unable to reach a mutually satisfactory agreement. The committee may vote to support the dean's position, your position, or suggest alternatives for the dean and you to consider. This committee reports to the provost and is composed as follows:

- One faculty representative from each of the following departments
 - Business Administration
 - English and Humanities
 - Fine, Digital, and Performing Arts
 - Health Sciences
 - Industrial and Engineering Technologies
 - Mathematical Sciences
 - Natural Sciences
 - Social Sciences
 - Teacher Education
- The registrar and the GEP director serve as voting *ex officio* members of the committee.

If the committee determines that a change in applicability is desirable, the committee chair reports the necessary change with rationale to you, the dean, and the registrar. If the committee determines that an applicability change is not warranted, the committee chair notifies you, the dean, and the provost regarding the decision and the rationale.

Level 3

If you and the Transfer Credit Appeals Committee are unable to reach a mutually agreeable resolution, you present your case to the provost. If the provost determines that a change in applicability is desirable, he or she reports the necessary change with rationale to you, the dean, the Transfer Credit Appeals Committee chair, and the registrar. If the provost determines that a change in applicability is not warranted, the provost notifies you, the dean, and the Transfer Credit Appeals Committee chair of the decision and the rationale. You have no further recourse within the institution. However,

if you wish to pursue the matter further, a state-wide appeals procedure is available.

Transfer Credit Appeals Committee

Membership. Faculty representatives to the Transfer Credit Appeals Committee are determined by a procedure agreed upon by the faculty within their respective units as indicated in Level 2. Committee members annually elect a chair. The committee chair votes only in the event of a tie. Staggered terms of three years begin January 1. Elected representatives may be required to meet during the summer months if a student submits an appeal during that time period. Deans may appoint alternates if necessary. The registrar and the GEP director serve as voting *ex officio* committee members.

International Students

International students who are seeking admission to Shawnee State University must submit the following materials:

- An application for admission and \$50.00 nonrefundable application fee
- All official secondary and postsecondary transcripts. These transcripts must be in the student's native language and be accompanied by a certified English translation. If these credentials cannot be evaluated by the University, they will be sent to an evaluation service, and you will be responsible for the cost of the evaluation.
- An official score of at least 500 on the Test of English as a Foreign Language (TOEFL) or an equivalent score on the Michigan Test of English Language Proficiency (MTELP) is required for admission to a degree program for students whose native language is not English.
- Proof of financial resources which are adequate to support the student for one year. If you intend to finance your education yourself, you must supply a statement from your bank showing funds equal to those required for one year. If you are being sponsored, an affidavit of support and a bank statement showing adequate funds for one year must be submitted.

International students are required to purchase health insurance while in the United States. Health insurance information may be found in the Bursar's Office.

Those international applicants who are accepted for admission will receive an acceptance letter and

an I-20 form to be used to secure a student visa. The acceptance letter and I-20 will not be issued until the Office of Admission has received all required materials. To be assured consideration for admission, all required materials must be received 60 days prior to the beginning of the quarter in which you plan to enroll.

Questions pertaining to a student visa should be directed to the local office of the Department of Immigration.

Non-Degree Students

Special Non-Degree Students

Students who are not interested in pursuing a degree but who wish to take courses are required to file an application for admission. Transcripts of high school and college work are not required, nor is ACT/SAT testing. However, if at a later time, you decide to pursue a degree program, all admission requirements in effect at the time of initial enrollment must be met. These requirements include official transcripts from high school (and/or GED) and college work and testing, recommendations, etc., if any of these are required for the major being declared.

Special, non-degree students may take courses which have no prerequisites or courses for which they have the appropriate prerequisite. For courses assuming prior knowledge or a certain degree of proficiency, placement testing may be advised or required prior to registration.

Transient Students

Students who are enrolled at or seeking a degree at another college or university, but who wish to take coursework temporarily at Shawnee State University, are considered transient students. As non-degree students (at Shawnee State), such students are required only to file an application for admission.

Although transcripts of high school and college work are not required of transient students, such transcripts, especially those from your home campus, are helpful in advising appropriate coursework. Unofficial transcripts or grade cards are acceptable if these are needed to verify prerequisites for courses to be taken at Shawnee State University.

Transient students are strongly advised to consult with the appropriate counselor or advisor

at the home college or university as to the appropriate coursework to be taken at Shawnee State and how that coursework will transfer to the home campus of the transient student.

If, as a transient student, you decide to seek a degree at Shawnee State University, you become a “transfer student” and are bound to all requirements for a degree-seeking transfer student, including whatever requirements existed for the major to be pursued at Shawnee State at the time of your initial enrollment.

Senior Citizens

Shawnee State University admits senior citizens (60 years of age or older) for courses on an audit, space-available basis. Although formal application and registration are required, no tuition fees are charged. Senior citizens who wish to take courses for credit may participate in the SSU Senior Scholar program, which pays tuition only. All other fees are the student’s responsibility. Applications are available in the Office of Financial Aid.

There is also a special, no cost, fitness program for seniors. Applications may be obtained at the James A. Rhodes Athletic Center.

High School Students

The Postsecondary Options Program (POP) offers academically talented high school students the opportunity to take, in a college setting, courses which enhance coursework available at their high schools and which are clearly at the college level. Students interested in this program must qualify during their eighth grade year to participate as a freshman, their freshman year to participate as a sophomore, sophomore year to participate as a junior, or in their junior year to participate as a senior.

Because the courses taken under this program are at the collegiate level, it should be expected that these courses are more demanding and completed at a faster pace than those taken in high school. They generally require more out-of-class preparation than high school classes. You and your parents should also consider the emotional and social maturity necessary to study in an adult environment in which most students are in their late teens/early twenties and assess your ability to accept independence and responsibility for your academic performance.

Eligibility

To be eligible for the Postsecondary Options Program, you must:

- Be a resident of the state of Ohio.
- Have completed eighth grade and be of freshman status, as defined by the school district. The application process begins during the student's eighth grade, freshman, sophomore, or junior years.
- Be commuting from your permanent residence and attending a high school within commuting distance.
- Meet two of the four following requirements: Provide evidence of passing all sections of the Ninth Grade Proficiency Examination or pass the High School Graduation Test (new in the 2002/03 academic year).

OR

Take the Shawnee State University placement test and place at a collegiate level in reading, English, and mathematics (i.e., 100 level or above). The test may be taken prior to application for the POP program.

OR

Provide official results of the ACT, with a score of at least 22 and 19, on the English and mathematics sections, respectively.

OR

Show evidence of a 3.0 grade point average (GPA) for the student's home school.

- Maintain a cumulative GPA of 2.0 (C average) for coursework at Shawnee State.

Qualified students have two options:

Option A (college credit only)

- You/your parents/your guardian pay for tuition, fees, books, and materials.
- All requirements listed under Option B below (except method of payment) apply to Option A.

Option B (high school and college credit)

- You must take placement tests and place at collegiate levels in math, English, and reading (or place by minimum ACT scores) if wishing to register for those areas. POP applicants are not required to take the placement test unless they wish to take English or math courses or courses requiring those competencies.
- You should seek counseling from high school personnel as to which college courses will meet graduation requirements at your school.

- Tuition, fees, books, and materials are paid for by the state, based on an established formula. **Note:** If you withdraw from a class prior to the end of the quarter, any and all fees may become the responsibility of you and your parent(s) or guardian(s), depending upon the school district policy.
- Successfully completed courses under Option B receive appropriate high school credit as determined by your school district. After graduation from high school, the college credits earned at Shawnee State as a high school student may be applied toward a Shawnee State degree or transferred to another university according to the transfer policies of the receiving institution.
- Courses may be taken under POP during fall, winter, and spring quarters only. However, students may take summer courses at their own expense.
- POP participants may register for a maximum of 16/18 credit hours per quarter, based upon remaining number of Carnegie equivalent units available at the high school.

Program Continuation

Students participating in Shawnee State's Postsecondary Options Program are required to maintain a cumulative GPA of at least 2.0 for all college courses completed. Students in Option B (tuition paid by state) whose cumulative GPA falls below 2.0 are not permitted to continue in the POP under Option B. They may participate under Option A (paying their own tuition) until the point at which their college GPA is once again 2.0 or above and their high school GPA is 3.0. Once the minimum GPA requirements are met at both Shawnee State and at the high school, they may continue under Option B again.

POP students must remain in academic and disciplinary "good standing" at the University and their local high school to remain eligible for this program. **Note:** Shawnee State University will honor any disciplinary action taken by the high school affecting a student in the Postsecondary Options Program.

Application

You must complete the POP application for admission and submit it to your high school counselor. The counselor should send the application, a copy of the applicant's high school transcript, and the Shawnee State verification/

acknowledgement form (acknowledging the student's understanding of the advantages, risks, and responsibilities involved in participation in the program), to the following address:

Office of Admission
POP Program
Shawnee State University
940 Second Street
Portsmouth, OH 45662-4344

A current transcript is required for each quarter of enrollment. The acknowledgement form is needed only once, at the time of application.

To participate in the POP program you must meet all requirements and apply by the May 15 deadline in the previous academic year. Students are not admitted after the May 15 deadline.

POP Orientation and Registration

A required POP orientation for students accepted into the program is held in August. Parents are encouraged to attend with their student.

Registration for fall quarter classes is by appointment for students who have attended the required orientation. Registration for classes is on a space-available basis and classes are subject to cancellation.

Students admitted to this program are permitted to register for most courses, provided necessary prerequisites are met.

Acceptance, Notification, and Reporting

In compliance with the law, ten days after completion of the application process, the following individuals are notified regarding admission status: the student, the student's parents (or guardian), the high school counselor, the district superintendent, and the state superintendent.

Validation of Credit

Grades are reported to you and/or your parent(s) or guardian as appropriate. For students who have chosen to use courses to complete high school requirements, the University will supply an official transcript of grades to the student's high school principal/counselor.

Other High School Students

Students in high school who wish to enroll outside of the POP program may do so under the following requirements:

- Courses are to be taken for college credit only.

- Your status will be Special Non-degree.
- Tuition, books, and fees are the responsibility of the student/parent(s)/guardian.
- You may attend only one course per quarter.
- You must show evidence of a 3.0 (A=4.0) grade point average (GPA) in your local high school. (The 3.0 GPA is not required for summer quarter attendance by high school students.)
- You must place into collegiate level math and English to enroll in courses requiring either proficiency.
- You must apply for admission, submitting the high school application for admission, and provide a written recommendation by your high school counselor or principal along with written permission from your parent(s)/guardian.
- School and parent/guardian recommendation and permission forms must be submitted each quarter of enrollment.
- Your course schedule must be approved by the Office of Admission or the Registrar.

Campus Tours

The Office of Admission, located in the Administration Building, offers group tours of campus, Monday through Friday, at 10:00 a.m., 1:00 p.m., and 3:00 p.m. The office also schedules Saturday appointments. For an individual campus tour and personal appointment, please contact the Office of Admission at 740.351.4SSU or 800.959.2SSU to schedule a time that is convenient for you.



REGISTRATION

INFORMATION



Registration

New students for fall quarter must register for their initial quarter during the New Student Orientation held each summer. (See “Orientation,” on page 26.)

If you are a degree-seeking freshman, you must contact the Student Success Center. Staff there help you obtain an advisor who assists you in planning your schedule. The approval signature of the academic advisor is **required** of degree-seeking freshmen with fewer than 45 credit hours earned. (See page 26 for more information on the Student Success Center.)

Continuing or returning students may register for subsequent quarters during any registration period. (Dates are found in the Academic Calendar, beginning on page 10.)

Designated registration “windows” are established to offer the opportunity to register on a priority basis. See the quarterly course schedule for more information.

The Office of the Registrar is open 8:00 a.m. to 5:00 p.m., Monday through Friday.

Improper Registration

Admission or registration may be canceled by the director of admission or the registrar in cases of improper registration or when false or incomplete information is provided on the application for admission, registration forms, or other official documents. In such cases, you will be notified in writing as to the action that was taken and the reasons for such action.

Selective Service Registration

Ohio law requires male students between the ages of 18 and 26 to be registered with the Selective Service System, unless they are on active duty with the armed forces of the United States (other than the National Guard or reserves) or legally excluded, to be eligible for state educational assistance programs. Residents who are not registered or have not indicated they do not need to register by the first day of the quarter are required by Ohio law to pay the out-of-state tuition. You can register with Selective Service in the year you become 18, and you must complete registration by 30 days after your 18th birthday. Selective Service registration can be accomplished in a few minutes at any

U.S. Post Office or via the Internet. If you wish to indicate exempt status, you can request materials to do so by contacting the Office of the Registrar.

Residency Information

A nonresident surcharge is assessed to any student who does not qualify as a resident for subsidy and tuition surcharge purposes, in addition to other university fees. You are treated as a resident of Ohio and are assessed in-state fees if:

- You are dependent upon at least one parent or legal guardian who has been an Ohio resident for the 12 months preceding your enrollment.
- You have been a resident of Ohio for the 12 months preceding your enrollment and during this time you have not received financial support from outside the state.
- You are the dependent child of a parent or legal guardian, or the spouse of a person, who, as of the first day of your enrollment, has accepted full-time employment and established a domicile in Ohio for other reasons than gaining the benefit of favorable tuition rates.

You may also qualify if you are self-supporting while in Ohio pursuing a part-time course of study (conditional residents), are stationed in Ohio while on active duty in the military or have been an Ohio resident while involved in active duty military service prior to enrollment, have worked as a migrant in Ohio, or have been requested to be out of the country by your employer. If you qualify under one of these conditions, your dependents may qualify as well.

Proof of residency may be presented in a Request for Resident Classification to the Office of the Registrar. This form and all documentation must be submitted by the following deadline dates in order to be effective for the desired quarter:

- May 1 for summer quarter
- August 1 for fall quarter
- November 1 for winter quarter
- February 1 for spring quarter

Retroactive residency determinations cannot be made for tuition surcharge purposes.

For information on residency, conditional residency, Selective Service requirements, or to receive a Request for Resident Classification, write or visit the Office of the Registrar.

Notification of Rights Under the Family Educational Rights and Privacy Act

The Family Educational Rights and Privacy Act (FERPA) affords students certain rights with respect to their education records. They are:

1. The right to inspect and review the student's education records.
2. The right to request the amendment of the student's education records to ensure that they are not inaccurate, misleading, or otherwise in violation of the student's privacy or other rights.
3. The right to consent to disclosures of personally identifiable information contained in the student's education records, except to the extent that FERPA authorizes disclosure without consent.
4. The right to file with the U.S. Department of Education a complaint concerning alleged failures by the State University to comply with the requirements of FERPA.
5. The right to obtain a copy of Shawnee State University's student records policy. You can obtain a copy of the policy from the registrar's office.

Student Success Center

The Student Success Center is designed to offer advising and registration services in many different areas. Staff work collaboratively with faculty members to provide advising for course sequencing and career goals.

Issues affecting your successful participation within the Shawnee State learning community are always at the forefront of the services the Student Success Center provides.

Determining your degree/program plan by using the Degree Audit System and the current Shawnee State catalog makes your decisions for registration much easier.

Other advising services include prerequisite checks, counseling at the time of complete withdrawal, reentry procedures for those students who wish to return, the completion of Academic Improvement Plans, and orientation to the University.

Placement Testing

All first-time, entering, degree-seeking students must participate in the University's placement testing program prior to registering for English and mathematics courses. If you are entering the University with credits from other colleges or universities, you must participate in the English and mathematics placement testing process if you lack transferable English or mathematics credits.

ACT or SAT scores may be used in place of placement results. If you enter Shawnee State University with an ACT English subscore of 22 or higher or an SAT English subscore of 520 or higher, you will be permitted to register for ENGL 111S. If you enter with an ACT mathematics subscore of 19 or higher or an SAT mathematics subscore of 460 or higher, you will be permitted to register for MATH 110S, 130, and/or 150.

Note: Students wanting to waive placement testing with ACT/SAT scores must present an "official" ACT/SAT score report at the time of testing or take it to the Student Success Center prior to registering for classes.

For students taking the placements and also, later, submitting ACT/SAT scores, ACT/SAT scores will have precedence over any placement results.

If you meet the qualifications for the mathematics portion of the test and wish to register in a mathematics class at a level higher than MATH 130, you must take the Advanced Placement Test. For information about this option, contact the Student Success Center.

The placement tests direct you into the university curriculum and ensure that you register for courses that match your level of academic preparedness for college-level coursework. If your placement is not determined by the above criteria, placement testing is mandatory. Placement is determined by test scores and other factors, which are determined by the appropriate division and may include ACT scores and high school background information.

Please contact the Student Success Center at 740.351.3594 for more information about the English and mathematics placement tests.

Orientation

New student orientation is required of every degree-seeking student entering Shawnee State University. As a first-year or transfer student at Shawnee State, you are special to us and we

endeavor to provide information that is crucial to being successful in college. The orientation process includes skills assessment in mathematics, English, and reading for appropriate placement into your initial courses in mathematics and English. Advising and registration for your first quarter courses occurs during the orientation session.

New student orientation also introduces you to the myriad of support services across campus. In and out of classroom success is vital during your college life. The Division of Student Affairs has committed to total student development by offering you the opportunity for personal and social growth. Orientation programs at Shawnee State provide you with an introduction to cocurricular activities. Student Orientation Leaders direct you throughout the session on student life, leadership programs, activities, and clubs and organizations that you can join. All sessions are fully interactive and allow you the opportunity to get answers to all of your questions and concerns. Sessions for entering first year and transfer students for fall term are held during spring quarter and throughout the summer. If you plan to enroll for winter or spring terms, a modified session is available during the term preceding your entry. For more information, please contact the Student Success Center at 740.351.3594.



FEES &
FINANCIAL
AID

Fees and Expenses

Registration fees are payable at the Bursar's Office prior to the opening of classes and in accordance with instructions issued with your quarterly bill. For students registering during late registration, fees are assessed as part of the registration process and are due at that time. If you make changes in your class schedule which result in an increase in your fees, it is your responsibility to go to the Bursar's Office to get a revised bill. No additional bills will be mailed to you as a result of dropping and adding classes.

The Bursar's Office is located on the second floor of the University Center. This places it near the Offices of the Registrar and Financial Aid and should make it easier for you to—in one place—take care of the “business” of going to college.

Fees may be paid by cash, check, money order, Visa, or MasterCard. It is important that you retain all fee receipts. Payment of fees owed is a prerequisite for continuing enrollment, and you should have sufficient funds (cash and/or financial aid) to cover expenses. Shawnee State University is not required to furnish services (registration, transcripts, etc.) to a student with unpaid fees.

Student Load

Students scheduled for 12-18 credit hours are considered full-time students. Students scheduled for fewer than 12 credit hours are considered part-time students. The permission of the registrar is required for you to schedule over 18 hours of credit. Please refer to the fee schedule for the rate per credit hour.

Certain students are restricted from carrying a course load greater than twelve hours. These students include first-time entering freshmen placed into two or more developmental education courses and any student placed on academic probation for a second consecutive quarter. A student affected by this policy may appeal to the director of the Student Success Center. In special cases, when this policy would jeopardize a student's participation in a degree program, a department chairperson may also request to waive the twelve-hour limit.

Quarterly Tuition

Special Note Regarding Fees

The fees listed below are current for the 2002-2003 academic year for “new” students (first term of attendance — Summer 2002 or after). Current fees for “continuing” students (first term of attendance Spring 2002 or before) are available from the Bursar's Office or by accessing the SSU website — www.shawnee.edu/offices/brsr/tuition.html. All fees are subject to change. Shawnee State University reserves the right to make, without prior notice, any fee adjustments that may become necessary.

Reciprocity

Students residing in the following Kentucky counties — Boyd, Carter, Elliott, Fleming, Greenup, Lawrence, Lewis, Mason, Rowan — may attend Shawnee State at Ohio resident rates. This reduction in fees is the result of a reciprocity agreement made by several colleges and universities in the area. This fee structure is subject to possible modification or cancellation.

Full-Time Students (12-18 hours)

Instructional Fee	\$ 1,275.00
General Fee	150.00
Technology Fee	24.00
Total Tuition (Ohio Resident)	1,449.00
Out-of-State Student Fee	1,032.00
Total Tuition (Out-of-State)	2,481.00

Part-Time Students

(Fees are per credit hour, up to 11 and above 18)

Instructional Fee	\$ 106.25
General Fee	12.50
Technology Fee	2.00
Total Fees per cr. hr. (Ohio Resident)	120.75
Out-of-State Student Fee	86.00
Total Fees per cr. hr. (Out-of-State)	206.75

Miscellaneous Student Fees

Bad Check	\$ 35.00
Credit by Arrangement(per cr. hr.)	155.00
Tuition	105.00
Administrative Fee	50.00

Credit by Exam	105.00
Education Field	155.00
Graduation Petition	45.00
Graduation Re-Petition	5.00
Health Sciences Application	17.00
ID Card Replacement	5.00
International Student Application	50.00
Lab Fees	<i>see below</i>
Late Payment	105.00
(Short Term Loan not selected)	
Late Payments on Short Term Loan (max. \$90.00 per quarter)	
First Late Payment	40.00
Second Late Payment	25.00
Third Late Payment	25.00
Parking Tag Replacement	20.00
Private Music Lessons	85.00
Short Term Loan	10.00
Transcript	5.00

Graduation Petition Fee

A graduation fee is required. You are not billed for this fee. It is your responsibility to pay this when you submit your petition to graduate. Your eligibility to graduate is determined by the registrar after you petition for graduation. See the above list for the graduation fee.

Health Science Application Fee

A nonrefundable health sciences program application fee must accompany all health science admission applications.

Lab Fees

A current schedule of lab fees is available in the Office of the Registrar. Formulas for the fees which exist at the time of this catalog's printing are listed on page 186.

Transcript Fee

The University will produce an official transcript upon written request from the student. See the above list for the transcript fee.

Responsibility for Fees

A student may register for classes by submitting a registration form in person or via the Web. With the act of registering, a student promises to pay all tuition and fees for the quarter. This financial obligation may only be discharged by paying in full, by choosing the Short Term Loan option, by

having adequate financial aid to pay the fees, or by withdrawing from Shawnee State University by the published deadlines. Please review the SSU course schedule, published in advance of each quarter, for details.

Short Term Loan

Shawnee State University provides a Short Term Loan (a payment plan option) that can help you with the payment of tuition, books, and certain fees.

Information about the Short Term Loan is available in the Bursar's Office.

Bad Check Policy

Payment of fees owed is a prerequisite to official enrollment, and you should have sufficient funds (cash and/or financial aid) to cover these expenses.

A check returned for insufficient funds is a federal offense and constitutes nonpayment of your obligation to Shawnee State University. Therefore, any student who has a check returned for insufficient funds shall be subject to all related fees; and, until the same is cleared, the student shall be considered in noncompliance with institutional policy and may be administratively dismissed.

Any student administratively dismissed due to a bad check has no recourse for readmission for the current quarter.

Student Insurance

Student health insurance coverage is available to all full-time students. If you wish to participate in this plan, please complete and return the enrollment form along with your payment to the insurance company. Enrollment forms may be picked up in the Bursar's Office.

Refund of Fees

Continuing students dropping hours through the fourteenth day of the quarter, when such changes result in a reduction of fees, are entitled to receive the reduction. Changes made after the fourteenth day of the quarter result in no refund.

Students who officially withdraw/drop from Shawnee State receive a refund, if due, based upon the following schedule. If you do not officially withdraw or drop, you are not eligible for any refund and fees assessed are due and payable.

Withdrawal/Drop Dates

Full Quarter

1 to 7 calendar days	100% of Tuition
8 to 14 calendar days	90% of Tuition
15 calendar days	0% of Tuition

Five-Week Summer Sessions

1 to 3 calendar days	100% of Tuition
4 to 5 calendar days	90% of Tuition
6 calendar days	0% of Tuition

Please Note: The five-week summer session refund schedule applies to students registered only in a five-week session. If you take classes from both a full summer (ten-week) quarter and a five-week session, refunds are issued under the regular term policy. Questions concerning the above information should be referred to the Bursar's Office.

Students wishing to see examples of these refund calculations may do so in the Financial Aid Office.

Late Payment Policy

A late payment fee is assessed when you fail to make payment in accordance with the due dates established by the Bursar's Office. Such fees are assessed in accordance with the fee schedule approved by the University's Board of Trustees.

Room and Board

Shawnee State University provides apartment-style residence halls within walking distance of all campus facilities. Students living on campus have access to a full service, buffet-style cafeteria in the University Center. The fees listed below include the 2003-2004 rates for each residence facility on campus and a 15-meals-per week meal plan.

Housing Application Fee \$ 150.00

First-time applicants, refundable (less a \$35 administration fee) if housing cancellation notice is received 30 days prior to first day of summer, winter, or spring quarters or prior to May 1 for upcoming fall quarter

Communications Feeper quarter \$ 68.00

telephone and internet services

Campus View Rates

Double Occupancyper academic year	\$6,309.00
.per quarter	2,103.00
Private Room (available as space permits)	
.per academic year	7,134.00
.per quarter	2,378.00

Carriage House Rates

Triple Occupancyper academic year	\$5,583.00
.per quarter	1,861.00
Double Occupancy (available as space permits)	
.per academic year	\$6,297.00
.per quarter	2,099.00

Cedar House Rates

Double Occupancyper academic year	\$5,928.00
.per quarter	1,976.00
Private Room (available as space permits)	
.per academic year	6,681.00
.per quarter	2,227.00

University Townhouse Rates

Double Occupancyper academic year	\$5,583.00
.per quarter	1,861.00
Private Room (available as space permits)	
.per academic year	6,339.00
.per quarter	2,113.00

Please see the special note regarding fees on page 29.

Financial Aid

An extensive financial aid program is available to help you meet the expenses of a college education. The financial aid program is administered by the Financial Aid Office and includes four categories: scholarships, grants, loans, and employment.

Application Procedure

To apply for federal assistance at Shawnee State University, you must complete and submit an original or renewal Free Application for Federal Student Aid (FAFSA) form to the federal processor. Federal aid consists of the Pell Grant, the Supplemental Educational Opportunity Grant (SEOG), Federal Work Study, Stafford Student Loan, and the Parent Loan for Undergraduates. Forms may be obtained from your high school counselor or the Financial Aid Office at Shawnee State. The FAFSA should be submitted as early as possible beginning in January preceding the academic year.

Federal regulations and institutional policies are subject to change without prior notice, but the Financial Aid Office attempts to keep you updated through various media on campus and with written notices. Therefore, it is very important that you update your permanent and local addresses with

the Office of the Registrar as necessary. Failure to notify the University of address and name changes can seriously delay your award and can be very costly to you.

Eligibility Requirements

Federal financial aid, Ohio Instructional Grants, and institutional scholarships require that you be fully admitted to a degree program. Federal aid also is available for approved study abroad programs. Federal recipients must have a complete financial aid file, including necessary verification documents, before funds will be awarded.

Federal aid is available to full-time students and, in lesser amounts, to part-time students. Eligible students enrolled for a less-than-half-time course load may receive Pell Grant funds. Full-time and part-time Ohio Instructional Grant funds are awarded.

Ohio residents are required to provide documentation of residence, including Selective Service numbers for male students, to the Office of the Registrar. Financial aid will not be disbursed until this requirement is met.

Notification and Disbursement

After your FAFSA needs analysis and other documents have been received and reviewed for accuracy (verified if applicable), you are notified in writing of any award for which you are eligible. If you are denied scholarships or grants, you are encouraged to continue in the process to be considered for supplemental forms of assistance such as loans or employment.

Disbursement dates and procedures vary depending on the type of assistance. Generally, financial aid awards are credited toward your account each quarter. When your grants and scholarships are greater than your university charges, you are issued a refund, in the form of a check, approximately three weeks after the quarter starts and weekly thereafter. Loan balances are returned to you by check after your scheduled disbursement dates.

Scholarships

The Financial Aid Office administers a number of special scholarships for students who demonstrate a high degree of academic ability or special

talent. Please apply on-line or contact the Financial Aid Office if you are interested in applying for a scholarship. The deadline for scholarship application is January 15. Your FAFSA should be submitted by February 15 for scholarship consideration.

Grants

■ **Federal Pell Grant.** Pell Grant funds are awarded based on expected family contribution, enrollment status, and the cost of education.

■ **Federal Supplemental Educational Opportunity Grant (SEOG).** SEOG is a federal grant awarded to undergraduate students on the basis of exceptional financial need beyond the Pell Grant. These funds are limited to the amount allocated to the University by the U.S. Department of Education. First priority is given to students who complete the FAFSA by March 1.

■ **Ohio Instructional Grant (OIG).** The OIG is a state-funded grant made available to eligible Ohio residents for meeting the cost of education. All Ohio residents who complete the FAFSA will be considered. Ohio Instructional Grants can be used for tuition only.

Please Note: Under the OIG program, you must be enrolled in an eligible associate or bachelor degree program.

Student Loans

■ **Federal Stafford Loan.** The Federal Family Education Loan Program (FFELP) includes subsidized and unsubsidized Federal Stafford Loans. The interest on a subsidized loan does not start to accrue until you graduate, drop below half time, or withdraw from school. The federal government pays the interest for you while you are in school. Payment of principal and interest does not begin until six months after you leave school, and you have up to 10 years to repay the loan.

You may also be awarded an unsubsidized Stafford loan. Interest on this loan is not government subsidized; interest begins accruing at the time the loan is disbursed. You may choose to pay the interest while you are in school or have the interest added to the principal loan amount (capitalized). As with the subsidized Stafford loan, payment of principal begins six months after you leave school and you have up to 10 years to repay the loan.

DEPENDENT UNDERGRADUATE STUDENT

Freshman (0-44 hours)	\$ 2,625
Sophomore (45-89 hours)	\$ 3,500
Junior/Senior (90+ hours)	\$ 5,500

INDEPENDENT UNDERGRADUATE STUDENT

(Loan limits also apply to dependent undergraduate students whose parents were denied a PLUS loan.)

Freshman (0-44 hours)	\$ 6,625
Sophomore (45-89 hours)	\$ 7,500
Junior/Senior (90+ hours)	\$10,500

■ **Federal PLUS Loan.** Additional opportunities to borrow are available through the Federal Parent Loan for Undergraduate Students (PLUS) program. Students should apply for, and finalize, a Stafford loan before applying for a PLUS loan because a PLUS loan could reduce the Stafford loan amount for which a student is eligible. (For most families, the terms of a Stafford loan are more attractive than those of a PLUS loan.)

PLUS loans allow parents to borrow up to the full cost of education minus other financial aid (including the unsubsidized Stafford loan). PLUS loans are not dependent upon your family's income or assets; however, a credit check is required. No collateral or cosigners are required.

The Federal PLUS Loan must be used for educational expenses at the school the student is or will be attending. Repayment begins in 60 days at a variable interest rate each academic year. The parent borrower is responsible for all interest from the day the loan is disbursed.

Please Note: Loan applications can be obtained from the Financial Aid Office. First-year, first-time borrowers cannot receive Federal Stafford funds until successful completion of 30 days of their first quarter. If you withdraw from the University, you are not eligible for your next quarter's loan check and you must reapply if you wish to continue receiving student loan funds.

■ **Student Emergency Loan Fund.** The Bursar's Office makes available to students, on a limited basis, small, short-term loans for direct or related educational expenses. These loans are interest free, but if not paid back, your academic records will be placed on administrative hold.

Employment

■ **Federal Work Study (FWS).** The FWS program is available to students who demonstrate financial need through the completion of the FAFSA. All vacant positions are posted on SSU's College Work-Study web page at www.shawnee.edu/prospective/financial. It is the student's responsibility to secure an interview. You must stop by the Financial Aid Office to obtain an "Authorization to Hire" form before being interviewed.

You are paid in accordance with current policy and, in most cases, work 10-20 hours per week. You are paid, based on the number of hours worked, every two weeks with the regular university payroll. Funding for FWS is limited, and first priority for open positions is given to students who complete the FAFSA by March 1. Indicate on the FAFSA that you are interested in a job. You may apply for work-study throughout the year in the Office of Financial Aid and will be placed on a job availability basis.

■ **Student Employment.** Regular student employment is available to all full-time university students, regardless of financial need, on the basis of current openings. Please contact the Office of Career Services for further details.

Veterans, State Programs

Veterans and students receiving assistance through approved state agency programs (Vocational Rehabilitation, National Guard, etc.) should contact the Financial Aid Office for assistance with course and attendance requirements and tuition payment.

Standards of Satisfactory Progress for Federal Financial Aid for Applicants and Recipients

Federal legislation requires Shawnee State University to define and enforce Standards of Academic Progress for students receiving federal financial aid. Failure to meet these requirements will result in the loss of federal aid until action is taken to regain eligibility. This policy is established for students who are receiving financial aid from one or more of the following programs: (1) Federal Pell Grant, (2) Federal Supplemental Educational

Opportunity Grant (SEOG), (3) Federal Work Study, (4) Federal Stafford Loan, and (5) Federal PLUS Loan.

Standards Requirements

Maintain Grade Point Average

Students must meet the grade point average requirements as defined in the “Academic Policies” section of the current Shawnee State University catalog. The student’s cumulative grade point average will be reviewed quarterly to ensure the following:

Credit Hrs. Attempted	GPA
Up to 40	1.00
41-55	1.30
56-65	1.55
66-75	1.80
76-85	1.90
86 and above	2.00

Complete 66% of Attempted Credit Hours

Satisfactory progress will be evaluated quarterly. Following the first quarter for which the student fails to meet minimum credit hour requirements, the student will receive a financial aid probation letter. Following the second consecutive quarter, financial aid will be terminated. Students who receive the following grades are considered to have attempted those credit hours: withdrawals (WD), incomplete (I), no credit (NC), failure (F), not reported (NR), and all passing grades (A, B, C, D, P). Course repetitions (R) count as hours attempted.

Complete Your Degree Within a Specified Time (150% of Graduation Requirements)

The financial aid regulations permit a student to use financial aid until the student has attempted 150 percent of graduation requirements. Bachelor degree students are eligible to receive federal aid through the quarter in which they attempt to earn their 279th credit hour. Associate degree students are eligible to receive federal aid through the quarter in which they attempt or earn their 135th credit hour.

Additional Definitions and Explanations

Attempted: “Cumulative number of hours” are the total hours attempted at Shawnee State University during all enrollment periods, irrespective of receiving financial aid. Course repetitions (R)

count as hours attempted. Total hours attempted may include no more than 45 quarter hours of developmental education credits.

Hours Earned/Hours Passed: Successful completion is measured by the number of “hours passed” recorded on the student’s academic transcript at the end of the evaluation period.

Academic Year: For purposes of measurement of progress, academic year is defined as enrollment during any or all of the following quarters: summer, fall, winter, and spring.

Enrollment Status: Federal financial aid recipients must be enrolled in approved degree or certificate programs.

Stafford Student Loans: In addition to the progress requirements listed above, federal regulations require that students progress from one grade level to the next before they are eligible to receive additional loan amounts. Students in associate degree programs may be certified for loans only at the freshman and sophomore levels.

Enrollment in a Second Degree: Students seeking federal financial assistance and pursuing a second associate or second bachelor degree must submit a degree audit signed by their academic advisor so that progress within the second program may be measured. This form is also used to determine grade level for federal loan certifications.

Failure to Maintain Satisfactory Progress

Students who fail the grade (qualitative) portion of the requirement are notified of their probation, or dismissal status by the Office of the Registrar.

The first time a student does not complete successfully the hours passed (quantitative measure), he or she is placed on **financial aid probation**. The deficiency must be satisfied in the next quarter of attendance. The probationary status, for students who continue to have a marginal deficiency at the end of the initial probationary period, may be extended. If the student does not achieve the required number of credit hours at the end of the probationary, or extended probationary, period, he or she is suspended from financial aid.

Suspension Due to Non-Attendance

Federal regulations require adjustment of financial aid awards for students who do not begin attendance in all classes upon which the awards were based. Adjustments are based on registrar records, including add/drop and withdrawal forms. Students are required to repay adjustment

amounts. Students who do not meet repayment terms are suspended from financial aid. (See appeal section.)

Reinstatement of Financial Aid

Unless eligibility is reinstated through appeal, students remain ineligible until that time when they are again in compliance with the standards. It is the responsibility of students seeking reinstatement to request the Financial Aid Office to review their records when they believe they are again in compliance with the requirement.

Appeals

Students may appeal to the director of financial aid. Students must submit a letter explaining the reason(s) for the failure and may be required to submit a degree audit from the student's advisor or other supporting documentation. If the director denies the appeal, the student may request, in writing, that the appeal be reviewed by the Financial Aid Advisory Committee.

Extenuating Circumstances Regarding Appeals

The major acceptable circumstances for making an appeal are the documented personal illness of the student, serious illness or death of an immediate family member (mother, father, sister, brother, husband, wife, child, legal guardian), or enrollment in a bachelor's program requiring more than 186 credit hours or an associate program requiring more than 90 credit hours.

The maximum number of credit hours attempted is considered to be adequate and fair under the progress policy. Change of major field of study, completion of developmental courses, or transfer of credits normally are not considered satisfactory grounds for appeal for additional time, but such appeals may be submitted using the process indicated above.

Unacceptable circumstances for appeals are: continued enrollment while seeking admission to an academic program (i.e., health science) or the prior nonreceipt of Title IV aid since this is irrelevant to maintaining satisfactory progress in the course of study.

Comments about the Progress Requirement

Students are encouraged to work with their academic advisors, the Student Success Center, the counseling center staff, and Student Support

Services' staff to receive study skills and tutoring assistance.

Students who withdraw from courses after the official add/drop period and students who receive grades of F, W, NC, R, and I greatly increase their potential for failing to meet the progress requirement.

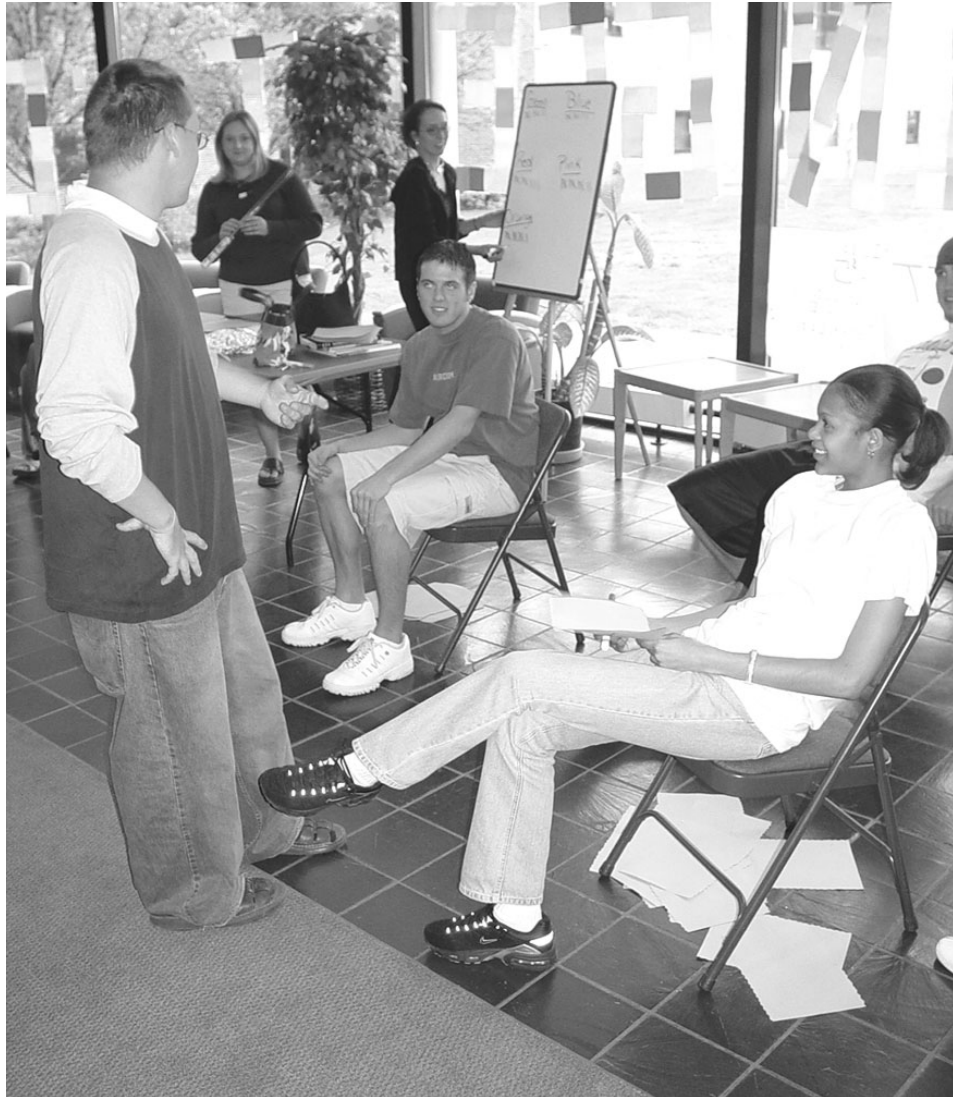

ACADEMIC
POLICIES AND
PROGRAMS

Academic Policies and Programs

Academic Integrity

Students at Shawnee State University are required to do their own work on all tests and assignments. Any form of cheating may result in your being withdrawn from a particular course or courses, as well as possible dismissal from the University. (See Student Handbook.)

Grading/Awarding of Credit

Final grades are mailed at the end of each quarter by the Office of the Registrar. Grades will not be issued orally.

Grade	Description	Quality Points
A	Excellent	4.00
A-		3.67
B+		3.33
B	Good	3.00
B-		2.67
C+		2.33
C	Average	2.00
C-		1.67
D+		1.33
D	Poor	1.00
D-		0.67
F	Failing	0.00
TC	Transfer Credit	0.00
KE	Credit by Exam	0.00
NC	No Credit	0.00
WD	Withdrawal	0.00
I	Incomplete	0.00
P	Pass	0.00
AP	Advanced Placement	0.00
AU	Audit	0.00
NR	No Report	0.00

A grade of F receives no credit. Students making this grade must repeat the course if credit is to be received.

Catalog Rights

The academic requirements and policies that a student must follow are determined by the course catalog in place at the time of initial registration at Shawnee State University. If a student fails to enroll for four consecutive quarters, he or she must follow requirements and policies in the course

catalog in place at the time of return to SSU. A student has the right to petition the academic department that offers his or her major for a change in catalog. A student also has the right to request course substitutions and waivers of requirements.

Waiver and/or substitution of a required course or courses must comply with SSU **“Guidelines Regarding Waivers and Substitutions of Required Courses.”** Copies of these guidelines are available from the dean’s office, College of Professional Studies; the dean’s office, College of Arts and Sciences; or the Office of the Registrar.

Finally, it is important to note the following statement printed on the inside cover of this catalog:

“These requirements are subject to change prior to graduation in order to comply with federal, state, and accreditation requirements. Shawnee State University reserves the right to make changes in its programs, policies, and procedures prior to your graduation, which you will be required to meet unless specifically exempted from the changes.”

Class Ranking

Student class ranking is determined by your cumulative credit hours earned and your degree program (please note the following chart). Non-degree seeking students do not possess class rank.

Degree Program	Class Rank	Cumulative Hrs. Earned
Associate	Freshman	0 - 44
Associate	Sophomore	45 - no upper limit
Baccalaureate	Freshman	0 - 44
Baccalaureate	Sophomore	45 - 89
Baccalaureate	Junior	90 - 134
Baccalaureate	Senior	135 - no upper limit

Incomplete Grades

If you are unable to attend class for an extended period of time, you may contact the faculty member responsible for the class to request an incomplete grade. Incompletes must be converted to a grade 30 calendar days after the quarter or they are recorded as Fs. This 30-day period begins the day after the last day of the quarter.

Administrative Hold

With the approval of the registrar, an administrative hold may be placed on the records or accounts of any student who fails to comply in a

reasonable period of time with an obligation imposed under university rules or who has an overdue debt or fine. An administrative hold will cause certain services to be withheld, including, but not limited to: obtaining current quarter grades, registering or enrolling, being certified as eligible to obtain a degree or certificate, receiving a transcript, borrowing books or equipment, or being certified to be eligible to participate in athletics.

The unit originating an administrative hold on your records or accounts will notify you in writing of the obligation that is overdue by providing another itemized bill or list of action requested, specifying when the administrative hold will become effective, whom you should contact for additional information, and how you should contact this person.

Any disputes concerning the legitimacy of the hold or its processing will be resolved by the registrar.

Academic Assessment

The value of an educational degree is directly related to the reputation of the university that awards it. For this reason, students on our campus are given the unique opportunity to actively participate in academic assessment. The feedback provided through assessment leads to changes that assure and maintain the quality and value of the academic programs at Shawnee State University.

Formal assessment testing, portfolio review, surveys, and exit interviews allow the University to assess the strengths and weaknesses of our programs. And, for all its benefits, the process actually requires a minimal amount of your time.

All students—except for transfer students and those classified as special nondegree students (see page 21 of this catalog)—are required to complete the Academic Profile twice. The first time is during your first quarter—before your grades are issued—and the second time is prior to your graduation. Special nondegree students are not required to participate. Please note: the Academic Profile is **not** the same test as Placement Testing (see page 26).

You must complete the Academic Profile during the quarter you are completing your degree or certificate or are enrolled in Senior Seminar in order to receive your degree or certificate.

By measuring what you've learned as well as what you can do with what you've learned, assessment helps you monitor your own progress, and it leads to changes that benefit future Shawnee State students and the University as a whole.

Dean's List/President's List

Full-time students (12 or more hours per quarter) who achieve a 3.5 to 3.99 grade point average are placed on the Dean's List for that quarter. Full-time students who achieve a 4.00 grade point average are placed on the President's List for that quarter.

Pass/No-Credit Policy

The pass/no-credit option is designed to permit you to take a select number of courses for which no traditional letter grade (of A through F) is recorded on your grade report and transcript. If you wish to take a course on a pass/no-credit basis, you must complete the proper forms at the registrar's office within the first 14 calendar days of a regular quarter or the first 7 calendar days of a 5-week term. Your decision to take a class on a pass/no-credit basis is not subject to change.

To be eligible for the pass/no-credit option, you must have earned a cumulative G.P.A. of 2.0 or better. First quarter freshmen are considered as having met the above requirement.

The pass/no-credit option is subject to the following restrictions:

- You may complete up to 8 quarter hours to be counted toward an associate degree or 16 quarter hours to be counted toward a baccalaureate degree under this option.
- You may take only one (1) course pass/no-credit per quarter.
- Applicability of courses taken pass/no-credit toward your major program of study is subject to departmental approval.
- To receive a grade of P (pass), you must earn a grade of C- or better in the course. If you do not receive a grade of C- or better, a grade of NC (no credit) is awarded.
- A grade will be turned in at the regular grade-processing time and will be converted to a P or NC on the transcript by the Office of the Registrar.

Credit by Examination

Students have the opportunity to earn credit for selected courses offered at Shawnee State University via proficiency examinations. If you have prior training, innate skills, extensive preparation, or experience, you may qualify to attempt the examination. You should first secure the advice of

your advisor or program director as to its appropriateness for your program of study. Then, final approval must be obtained from the appropriate chairperson, program director, or dean. Please note that only selected courses are available “by examination.”

A fee is charged for course credit by examination and must be submitted prior to attempting the examination. A “KE” symbol, indicating “credit by exam,” is recorded on the academic transcript of those students who demonstrate proficiency by passing the exam. Credit earned by examination is not included in the calculation of your cumulative grade point ratio. You are not eligible to attempt a proficiency examination for a course in which you have been enrolled for 20 class days or more.

Credit hours awarded by examination do not apply toward the residency requirement for graduation.

College Level Examination Program (CLEP)

Students may be awarded credit for College Level Examinations taken under the College Entrance Examination Board. If you take the general examinations in English composition, mathematics, natural sciences, humanities, social sciences, and history and achieve the recommended scores of the Commission on Educational Credit and Credentials of the American Council on Education (ACE), you are given KE credit for the first sequential course in the above areas.

Many subject examinations may be used to earn KE credit for courses in the same subject areas, but you must achieve recommended ACE scores to receive credit.

Credit given through the College Level Examination Program does not apply toward the residency requirement for graduation.

For more information regarding taking a CLEP exam, contact the Student Success Center.

Credit for Military Educational Experiences

Credit may be awarded for military educational experiences. The Guide to the Evaluation of Educational Experiences in the Armed Forces, published by the American Council on Education, is used to determine possible college credit eligibility.

Credit awarded for military educational experiences does not apply toward the residency requirement for graduation. Please contact the Office of Transfer Placement for more information.

Prerequisites

Most learning beyond basic skills is dependent upon the mastery of some prior skill or subject content. As a result, many courses at the University require the satisfaction of prerequisites prior to course enrollment. Prerequisites may be met by successful completion of the prior courses listed or by placement, via testing, into the course.

The academic division/school may request that a student be withdrawn from a course for which prerequisites have not been satisfied.

Repeating Coursework

Courses may be repeated for credit if so identified in the course description located elsewhere in this catalog. Courses may also be repeated for other purposes (e.g., attempt to raise grade), but only the highest grade earned and the associated credit will be reflected in your GPA (grade point average). The lower course grade will be replaced by the symbol R, indicating the course was repeated.

While most courses are eligible for repetition, the following transcript symbols cannot be removed by subsequent course repetition: WD, AP, P, KE, NC, AU, TC (please note Grading/Awarding of Credit section on page 37 of this catalog).

Grade Appeals

If you question a grade in a particular course, you must contact the faculty member or the academic department responsible for the class for information on the grade appeal process.

Grade Point Average

Quality points for a course are determined by multiplying the total credit hours by the numerical equivalent of the letter grade received in the course. The formula for calculating grade point average is:

$$\frac{\text{Total Quality Points}}{\text{Total Division Hours}} = \text{Grade Point Average}$$

Academic Probation

A student achieving a grade point average of 1.5 or less for any quarter is placed on academic probation for the following quarter provided the cumulative grade average does not fall below that required to remain enrolled.

Fresh Start

The Fresh Start policy allows former students with poor grades and other circumstances to reenter the University and have prior grades disregarded for GPA computation purposes. For details, please contact the Office of the Registrar.

Academic Suspension/Dismissal

Students are academically suspended when their cumulative grade point average falls below that listed for each category of credit hours attempted:

Credit Hrs. Attempted	<40	41-55	56-65	66-75	76-85	86+
GPA	1.00 or below	1.30 or below	1.55 or below	1.80 or below	1.90 or below	2.00 or below

An academically suspended student may reenroll on “academic warning status” after two quarters. A second suspension results in academic dismissal. “Academic dismissal” is the permanent withdrawal of the privilege of enrollment and attendance.

Audit (Non-Credit)

You may elect to take a course for non-credit (audit) during the first 35 class days of a quarter (17 days of the 5-week summer sessions) by completing the proper forms in the Office of the Registrar. Election of this option may affect federal financial aid eligibility.

Course Credit by Arrangement

Students have the opportunity to fulfill requirements for selected courses offered at Shawnee State University via independent study or specially arranged instruction. If you are interested in pursuing this educational option, you should first secure the advice of your faculty advisor as to its appropriateness for your program of study. You should then contact the appropriate dean, director, or chairperson. This individual, after consultation with appropriate faculty, makes a determination as to the feasibility of your request. You may earn up

to 18 credit hours toward graduation in this manner, with all credit being considered resident credit, but you are limited to eight hours of credit by arrangement per quarter. Students enrolling in a course by arrangement have until the date grades are due the following quarter to have all work completed in the course.

Credit hours attempted/earned via this option do not count toward full-time student status except in the computation of federal financial aid eligibility. See the fee schedule for course by arrangement fees. All fees must be paid prior to the beginning of the course.

Internship Guidelines

Guidelines for internship have been established by faculty for those programs which require internship as part of their graduation requirements. If internship is a part of the program in which you are enrolled, you are urged to request a copy of the guidelines from your faculty advisor.

Faculty Advising

Academic advising is intended to help you with your immediate academic concerns. Toward that end, advising is provided to degree-seeking students by faculty advisors.

Faculty members will meet with you by appointment, and each faculty member has available hours posted near his or her office.

Undecided students, pre-health science students, and students who place into two or more developmental courses (math and/or English) are guided by Student Success Center advisors.

Faculty Expectations and Responsibilities

Faculty expect regular and punctual attendance at all classes. Attendance policy for individual classes is made by the faculty member responsible for the class. Grades are also controlled by the faculty member responsible for the class.

In the event that a faculty member is not present at the normal time class begins, you are to remain in the classroom an additional 15 minutes. If the class meets once a week for 3 to 5 hours, you must remain in the classroom for 45 minutes. If the faculty member has not arrived or no special instructions have been received within that time, you may leave class without penalty.

All faculty members post office hours during which they are available to discuss individual problems relating to your academic progress. You are encouraged to take full advantage of your academic advisors. They want to see you succeed.

Visitors to Class

Students planning to bring a visitor to a class with them are asked to obtain the permission of the faculty member responsible for the class in advance of the visit.

Bringing Children to or Leaving Children at the University

Children are welcome at the University, with you, at any family event. However, please do not bring children to the University and leave them unattended while you are in class or at another university-related event. The University cannot be responsible for children who are left unattended.

Adding a Class

You may add a class to your schedule through the first five class days of the quarter (three days of a five-week summer session) by completing a registration form in the Office of the Registrar.

Dropping a Class

You may withdraw from a class through the seventh calendar day of the quarter by completing the proper form (or its electronic counterpart) in the Office of the Registrar. During the first seven calendar days, if class withdrawal affects fees, a refund is possible. Any withdrawal after the seventh calendar day results in a WD being placed on your academic record. Withdrawing from courses may affect Title IV student financial aid funds. Please read the Financial Aid Satisfactory Progress section on pages 33 through 35 of this catalog.

You may withdraw from a class the 8th through 49th calendar days of the quarter by obtaining the signature of the instructor on a form obtained from the Office of the Registrar. The form must be returned to the Office of the Registrar.

In case of emergency, as determined by the college dean, you may withdraw from a class after the 49th calendar day, but no later than 5:00 p.m. on the final day of class, by obtaining permission from the college dean and completing appropriate

forms. Faculty members are notified by the college dean of these emergency withdrawals.

Withdrawing Completely

Should your circumstances warrant a complete withdrawal from the University, you must contact the Office of the Registrar to complete the proper forms. The staff will direct you to the Student Success Center where proper information is given regarding the possible academic and financial aid ramifications of complete withdrawal. Many times, staff in the Success Center can provide alternatives so that departure can be avoided. It is never advisable to withdraw from the University without first speaking to a representative from the Success Center. Additionally, reentry into the University is made more convenient for you by the Center's staff. You will automatically receive subsequent quarter schedules with an invitation to register.

Grades for scheduled classes are recorded as withdrawals (WD). See the fee schedule for our refund policy.

If you do not follow the withdrawal procedure, you are considered enrolled in the class and are graded accordingly.

Transcripts/Grade Reports

Each quarter you receive a grade report that includes grades achieved that quarter. Please contact the registrar within 30 days of receiving the grade report if you discover an error.

You may request transcripts from the Office of the Registrar. Requests for official transcripts must be in writing and addressed to the Office of the Registrar. Refer to the "Fees and Expenses" section of this catalog for the transcript fee.

Shawnee State University is not required to furnish a transcript to any student whose financial obligation to the University has not been satisfied.

Graduation Requirements

In addition to the specific requirements listed by the individual divisions, the following are general graduation requirements for all students at Shawnee State University:

- **Baccalaureate Degrees**—A minimum of 186 credit hours, including the 48 credit hours of the General Education Program.
- **Associate Degrees**—A minimum of 90 credit hours.

- A minimum of a 2.0 cumulative grade point average for all courses taken at Shawnee State University and in your major field of study.
- A minimum of 60 credit hours in the major field of study (baccalaureate's degrees).
- Petition for graduation in accordance with the rules prescribed by the University.
- Receive recommendations of faculty in academic major.
- Complete a minimum of 30 hours of credit for the associate degree or 45 hours of credit for the baccalaureate in residence at Shawnee State University.

Students having outstanding institutional bills or notes are not issued a degree. You must petition to graduate by the deadline published in the calendar. Petitions are available in the Office of the Registrar.

Graduation with Honors

■ **Students entering SSU prior to the 1997-98 academic year.** Students who achieve a cumulative grade point average of 3.25-3.49 prior to the quarter of graduation are graduated cum laude. Students who have achieved a cumulative grade point average of 3.50-3.74 prior to the quarter of graduation are graduated magna cum laude. Students who achieve a cumulative grade point average of 3.75 or above prior to the quarter of graduation are graduated summa cum laude.

■ **Students entering SSU during the 1997-98 academic year and thereafter.** Students who achieve a cumulative grade point average of 3.5-3.74 prior to the quarter of graduation are graduated cum laude. Students who have achieved a cumulative grade point average of 3.75-3.89 prior to the quarter of graduation are graduated magna cum laude. Students who achieve a cumulative grade point average of 3.9 or above prior to the quarter of graduation are graduated summa cum laude.

Honors Program

Shawnee State University has designed its Honors Program for students with exceptional academic ability and curiosity. The courses designated as fulfilling the Honors Program give these students unique opportunities for reflection, discussion, and investigation while also fulfilling certain standard graduation requirements. The program brings these students together in a challenging but

supportive environment which nourishes their intellectual, social, and creative growth.

■ **Honors Classes.** The Honors Program requires 20 hours of special Honors sections of general education requirements. In addition, Honors Students are required to take one Honors Symposium. Symposia focus upon subject matter and texts not typically taught in other courses, and which not only challenge the students intellectually, but also give them insight into significant thinkers, ideas, or historical eras.

■ **Other Activities.** The Honors Program organizes special trips, outings, and activities for Honors Students that are both academic and social in nature.

Honors Program Admission Policy

Honors applicants qualify for admission if their academic standing places them in one or more of the following categories.

- Incoming full-time freshmen whose scores on the ACT or SAT provide evidence of high academic potential;
- Incoming full-time freshmen who are (a) in the upper 10 percent of their high school graduating class, or (b) in the upper 10 percent of the incoming freshman class;
- Current full-time Shawnee State University students who have completed at least 40 credit hours and have earned a cumulative GPA of 3.5 or higher. This includes associate degree students who decide to obtain a baccalaureate degree.

Requirements for Honors Program Graduation

Satisfactory completion of the 20 hours of general education requirements specifically designated as Honors Courses and the Honors Symposium qualify a student for graduation from the Honors Program. Honors students must maintain a cumulative GPA of 3.25 or higher to remain in the Honors Program.

For further information about the Honors Program, please contact Dr. Clifford Poirot, director, Honors Program, Commons Building, room 125 or phone 740.351.3396.

Graduate Center

Shawnee State University's Graduate Center provides busy professionals and community residents with a means of achieving their educational goals within close proximity to their homes and places of employment. In partnership with other universities, graduate classes leading to master's degrees are offered on the Shawnee State University campus. Most courses are taught by these universities in the evenings or on weekends, using various modes of delivery, including interactive video and in-person instruction.

Shawnee State is currently developing two master's degree programs in occupational therapy and education.

For more information or to inquire about the status of these new programs or about graduate studies in general, please call the Graduate Center at 740.351.3177.

Center for International Programs and Activities

Shawnee State University welcomes students from many cultures. The Center for International Programs and Activities (CIPA) is designed to help our international students fully participate in their college experience. The CIPA director coordinates campus services and programming which enhance our international students' social and academic success. Working in conjunction with various campus offices, CIPA assures that our international students find individual attention specific to their concerns and to their own life, educational, and career goals.

The Center's mission is to provide Shawnee State University's students and its community with opportunities to appreciate different values and cultures around the world. These experiences prepare our students for the increasingly global nature of society, encourage their understanding of other people, and enable them to contribute to the well being of our world community. On behalf of Shawnee State University, the Center for International Programs and Activities fosters and promotes international understanding and global perspective to the university community and the region served by Shawnee State.

For More Information

John H. Lorentz, Ph.D., Director
Center for International Programs and Activities
Shawnee State University
940 Second Street
Portsmouth, Ohio 45662-4344
Phone: 740.351.3127
Fax: 740.351.3153
E-mail: jlorentz@shawnee.edu
Web Site: www.shawnee.edu/acad/cipa/cip.htm

International Relations Degree

Located academically in the Department of Social Sciences in the College of Arts and Sciences, the bachelor of arts with a major in international relations examines the nature of the global economy, communications, politics, and cultures; the consequences of environmental interdependence among regions of the world; and the unfolding of a variety of other crossborder issues. The BA in international relations provides its graduates with the conceptual and substantive tools necessary to function more advantageously and effectively in a "shrinking" world.

International Study Programs

To give you an opportunity to broaden your foreign study experience, the University sponsors international awareness and exchange programs, as well as travel and language study abroad. Shawnee State also takes great pride in the international faculty who teach at the University. These faculty, and the students we welcome from other countries, share their international perspectives every day and enrich the lives of everyone in the Shawnee State academic community. International programs at Shawnee State may take many forms: courses taught by university faculty, courses at foreign educational institutions, field studies, internships, and student exchange programs. On occasion, the University sponsors an International Awareness Week and hosts visiting foreign scholars and lecturers. In order for its students to benefit from a variety of international study options, Shawnee State University has established sister-university agreements with the Zhejiang University of Technology in China, with James I University in Spain, and with the University of Applied Science in Zittau, Germany. If you are interested in an international exchange opportunity, you should

plan early, consulting with your faculty advisor and with the director of the Center for International Programs and Activities.

Academic Support

Supplemental Instruction (SI)

The Student Success Center, in conjunction with selected academic departments, offers supplemental instruction (SI) on a course-by-course basis. Facilitated by student leaders under the direction of a faculty member and the Student Success Center, SI is intended to help students understand course material presented by faculty and to augment in-class activities. Contact the Student Success Center or academic department chairperson for more information.

Tutoring

The Student Success Center offers peer tutoring to students who may be experiencing difficulty with their courses. If you need help understanding course concepts or completing assignments, you can request a peer tutor. If you would like to be a tutor, you must be recommended by faculty from the discipline and must have received no lower than a B in the course. Interested students should apply at the Student Success Center.

Computer Labs

The Student Success Center is home to the largest open computer lab at Shawnee State University. There are nearly ninety computers dedicated for student use and networked via a Windows NT server, which allows for quick, user-friendly access to e-mail, OhioLink, and World Wide Web browsing.

All the computers in the Student Success Center are connected to one of three Hewlett-Packard laser jet printers. Two scanners, one color and one black and white, are also available for students to scan either graphics or text, which can be manipulated similar to a regular word processing program. In addition to the printers mentioned above, a color laser jet is also available for student use. There is a minimal fee for printing color prints.

Developmental Education

If you lack college-level academic skills in basic English, mathematics, or science, you may choose or be advised to take developmental courses in these areas. Furthermore, in instances where placement test outcomes indicate an explicit need for college preparatory coursework, you are required to take certain developmental courses before registering for some university courses.

Developmental courses provide underprepared students an opportunity to gain the skills and knowledge necessary to attempt college-level coursework. They are intended for students who have had no background in a subject (e.g., biology and physics), inadequate preparation in a subject (e.g., mathematics, writing, reading), or have been away from school and need review. Credit hours earned in developmental courses, excluding UNIV 101 and 102, cannot apply toward degree requirements.

The Departments of Arts and Humanities and Mathematical Sciences offer the following courses. Their descriptions are found in the "Course Description" section of this catalog, beginning on page 183.

BIOL 099	Fundamental Biology
ENGL 095	Basic Writing 1: Mechanics
ENGL 097	Reading Development 1
ENGL 098	Reading Development 2
ENGL 099	Basic Writing 2: Parag. and Essays
MATH 099	Fundamental Mathematics
PHYS 099	Fundamental Physics
UNIV 101	Academic Development Skills
UNIV 102	Personal Development Skills

Clark Memorial Library

Opened in 1991, but designed for the 21st Century, the Clark Memorial Library, a charter member of OhioLINK, offers high tech library options in relaxed, friendly surroundings. Comfortable seating for reading and study, conference rooms for group work, seminar rooms with satellite and Web technology for teleconferencing and other distance learning activities, and a 350-seat lecture hall provide for a diverse range of student needs. Printers, scanners, and computers (PC and Macintosh) loaded with software for wordprocessing/spreadsheets/databases, presentation packages,

e-mail, and Web applications allow students to accomplish many different activities within the Library.

Reference and information counter staff are always present and ready to personally assist any student who wants help locating information or using the Library's resources.

On-line catalogs and research databases, accessible in the Library and across campus, can also be used from homes, schools, and businesses across the region around the clock. Seventeen thousand ebooks and 10,000 magazines, journals, and newspapers, in electronic full text, augment the Library's hard copy collections. Multimedia, streaming video, audiovisual materials, and production facilities complement Clark Memorial Library's traditional print collections.

To supplement local cataloged resources, students can order, electronically and at no cost, virtually any of the millions of items available in the OhioLINK system. An intercampus circuit of pickup and delivery assures that items requested from other campuses will be available for checkout at the Clark Memorial Library Circulation Counter within three working days. And, as a member of the U.S. Government Depository program, the Clark Memorial Library also provides not only government documents in print but also Web access to many government resources.

Clark Memorial Library shares the University mission statement and recognizes the importance of knowledge, values, and cultural enrichment. The library program is committed to collaborating with faculty to provide undergraduates an education that fosters competence in oral and written communication, scientific and quantitative reasoning, and critical analysis/logical thinking. Library staff promote information literacy and are committed to helping students gain "the ability to access, evaluate, and use information from a variety of sources." Service to the library user is a high priority whether the user is in the library to research for a class assignment or logging into the library website to link to one of the numerous online reference resources.

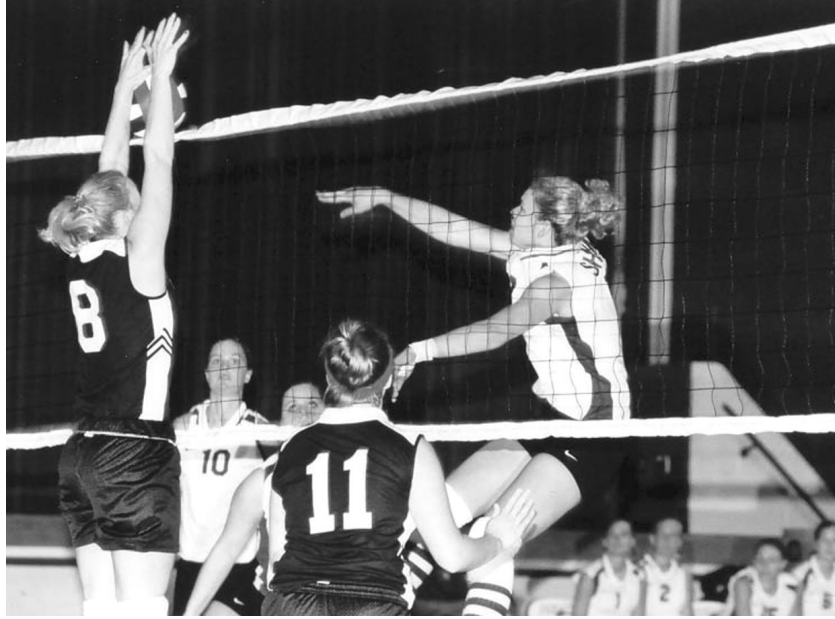

STUDENT DEVELOPMENT



Athletics

Shawnee State University's philosophy holds that there is more to learning than academics. Besides attending classes, every student has the opportunity to participate in recreational or athletic activities, which at Shawnee State are intercollegiate, intramural, or individual in nature. You may review the annual report disclosing "Equity in Athletics," which is available in the athletic office and the office of the vice president for student affairs.

Intercollegiate Athletics

Intercollegiate athletics at Shawnee State University promotes the education and development of student athletes through athletic participation. The athletic department shares the University's commitment to high standards and embraces the concept of the student athlete. Educational development is the central focus of the department.

We believe that a learning experience is not confined to the classroom or laboratory, but is a combination of your total college experience. That's why our athletic program is viewed as a cocurricular activity and, as such, is considered an educational experience. Students are involved in our athletic programs as student athletes, student assistant coaches, statisticians, trainers, managers, cheerleaders, and ushers. The goal of the Shawnee State Athletic Department is to insure that the intercollegiate athletic experience is one from which our students can learn and grow.

Athletic policies at Shawnee State conform to the National Association of Intercollegiate Athletics (NAIA). Currently, Shawnee State fields teams in men's and women's basketball, cross country, and soccer; men's golf and baseball; and women's volleyball, softball, and tennis. The University's intercollegiate athletic teams are affiliated with the American Midwest Conference (AMC).

Intramural Sports

Competitive sports and recreational activities are a desirable part of your educational program. Through participation, you develop an appreciation of the worthy use of leisure time and a wholesome attitude toward physical activity.

The Intramural Department conducts activities of interest to the men and women of Shawnee State University. The department's goal is to provide an

opportunity for every individual to participate in some activity of his or her own choosing. Intramural activities are organized on a team and individual basis so that everyone can participate. Ability is not the issue; the only requirement is a desire to participate.

Bookstore

The Shawnee State University Bookstore operates on a self-serve basis for the convenience of students, faculty, staff, and the public at large. The Bookstore provides the textbooks and supplies necessary to complete required coursework and also makes available items such as calculators, computer supplies, swimming and racquetball equipment, art and drafting supplies, gift items, and a wide selection of imprinted campus wear.

Children's Learning Center

The Children's Learning Center (CLC) is a preschool operated in conjunction with Shawnee State University. The director and members of the CLC staff serve as adjunct faculty for the Department of Teacher Education. Preschool teachers hold a minimum of a bachelor's degree with expertise in the field of early childhood education, and teacher assistants are enrolled as full-time students in teacher education licensure programs.

The Center serves the University and community.

Academic Support The CLC is an important resource for SSU students enrolled in two-year and four-year early childhood programs. Pre-service teachers observe and interact with children as part of their required coursework. Clinical work may consist of field experiences, practicums, or internships in a specified area of study.

A Community Resource As a model early childhood site, the CLC may be the only point of contact for individuals not associated with Shawnee State University. It is for this reason that the CLC strives to provide positive and effective communication between the University and the surrounding community.

For More Information

Cynthia Ferguson, M.Ed., Director
 Becky Herpy, Secretary
 Children's Learning Center
 Shawnee State University
 940 Second Street
 Portsmouth, OH 45662-4344
 Phone: 740.351.3252
 Fax: 740.351.3184
 E-mail: bherpy@shawnee.edu
 cferguson@shawnee.edu

Counseling

The University provides a variety of counseling services through the different offices of Student Affairs. Placement, financial aid, veteran's, educational, personal, and vocational counseling are available to you free of charge.

Counseling and Psychological Services

The Counseling Center offers personal, confidential counseling to help you cope with problems which may affect your personal life or interfere with your academic progress. Services include:

- Individual evaluation and assessment
- Crisis intervention counseling
- Individual, couple, and group counseling
- Safe sex counseling
- HIV/AIDS testing and counseling
- Biofeedback therapy
- ACT Residual Testing
- Skills development training (i.e., stress management, coping with test anxiety, time management)
- Education/prevention workshops (i.e., drugs and alcohol, safer sex, personal safety)
- Referral services
- Consultation services

Counseling and Psychological Services, located on the second floor of the University Center, is open from 8:00 a.m. to 5:00 p.m., Monday through Friday, and evenings by appointment. You are encouraged to schedule an appointment by calling

740.351.3213, but every attempt will be made to accommodate students on a walk-in basis. All services are free to Shawnee State students.

Career Services

The Office of Career Services is designed to serve your career planning and job placement needs. You are invited to meet with a career counselor to explore various career options. In addition, a career lab houses computers equipped with a wide variety of career exploration software. You may work independently, at your own pace, exploring career fields and educational opportunities afforded by graduate or professional schools.

As graduation approaches, you are encouraged to take advantage of the job placement services available through the Office of Career Services. Workshops in resume writing, cover letter composition, interviewing skills, and job search strategies prepare you for the job search process. In addition, the annual Job Fair brings employers to campus for the purpose of meeting and interviewing students nearing graduation. Representatives from business, industry, education, health care, and social service agencies regularly attend the Job Fair. Furthermore, the office maintains a Web page that lists selected job opportunities, updated regularly.

While you are attending college, the office can assist you in securing on-campus or off-campus part-time employment. Following graduation, the office provides alumni services to accommodate your changing job placement needs.

The office is located on the second floor of the University Center and is open Monday through Friday, 8:00 a.m. to 5:00 p.m. The office may be reached by calling 740.351.3213 or via fax at 740.351.3551. If you are interested in viewing our web page, please point your browser to www.shawnee.edu and click on Career Services.

Student Success Center Multicultural Student Affairs

International students arrive from many parts of the globe to study at Shawnee State. Some are from Japan, Indonesia, Mexico, Brazil, Belarus, Nigeria, Kenya, Ethiopia, Cambodia, and Spain.

Services offered through Multicultural Student Affairs include on campus and diversity enrichment programs for international students, students of

color, and the university community. A variety of services are available, including academic advising, tutorial services, orientation, time management, and study skills. A resource library lists multiethnic publications and literary works available for students to use. Scholarship information is available for undergraduate and graduate students and for students interested in doctoral degree programs. Referrals to community resources for health care and other services are also provided. During spring quarter, international students who are the first to represent their country at SSU are honored with an introduction and flag placement at the University Center.

The Multicultural Student Affairs office also offers guest presentations throughout the academic year to celebrate the different cultural anniversaries. Leadership programs held at other regional campuses in Ohio provide our culturally diverse students the opportunity to meet and interact with their peers. The most rewarding program celebrated is the “Heritage” program that honors each graduating student. The Multicultural Student Affairs office is located in the Student Success Center.

Disability Services

Shawnee State University advocates a barrier free campus and provides a variety of support services to all disabled students. Support includes classroom accommodations, technical assistance to improve learning, and the removal of structural barriers. Documentation of each student’s disability, their capacity for learning, and prior classroom services provided are necessary in order that proper accommodations are established and communicated to the faculty member. Students are asked to submit their class schedule for each academic quarter so that services are consistent with the learning process. Support services allow each student at Shawnee State to pursue a particular area of study, empowering the student to realize their own unique potential for success.

The office also acts as a liaison between the student and sponsoring regional agencies such as the Bureaus of Vocational Rehabilitation and Visual Impairments. Orientation for new students is available during campus visitations or by appointment with the office.

Student Support Services

Student Support Services, funded through a grant from the U.S. Department of Education, offers a variety of assistance to qualified Shawnee State students. To qualify for the program, you must meet income guidelines, be a first generation college student, or have a documented physical or learning disability.

Completion of an application form and a personal interview with program staff are required. Once you are accepted into the program the following services are available:

- Professional tutoring in math, English, and science
- Career counseling
- Personal counseling
- Cultural experiences
- Peer tutoring and mentoring
- Loaner calculators and tape recorders
- Computer lab

Student Support Services is located in the Trio Center on the first floor of the Administration Building. The office is open Monday through Friday from 8:00 a.m. to 5:00 p.m. Evening appointments are also available upon request. Please call 740.351.4SSS (4777) for further information.

Health Services

The University provides an on-campus student health clinic for the treatment of minor illnesses or injuries.

The health clinic is staffed with professional medical personnel to assist and treat medical concerns and, if necessary, make referrals to local agencies or the Southern Ohio Medical Center for major illnesses.

Specific information about the health clinic can be found in the student handbook.

Student Activities

Identification Cards

Identification cards are issued to Shawnee State University students by the Office of the Registrar and are the means of identification necessary for

using the Library and participating in student activities. You must present evidence of registration when you receive your I.D. card.

Office of Student Activities

The Office of Student Activities and Auxiliaries prepares students for their postcollegiate experience by encouraging responsibility, teaching critical thinking skills, and providing opportunities for personal and social development. In addition, the Office provides facilities and services to on- and off-campus constituencies in an effort to build community on campus and within the surrounding areas. Ultimately, the Office provides an environment that fosters our students' social, cultural, and educational experiences.

Shawnee State University is dedicated to the principle that many valuable experiences should be provided for college students outside the academic area. The Office of Student Activities encourages you to share your ideas—and then, to help develop the programs that enrich the lives of Shawnee State's students.

Student activities are a good way for you to meet new friends, develop new interests and skills, and participate in valuable leadership experiences.

Many clubs and organizations are sponsored by the office, including the Student Government Association, the Student Programming Board, and Greek organizations. If you would like information about an existing club or organization or if you're interested in starting a new activity, please contact the staff in the Office of Student Activities.

University Center

Shawnee State's University Center was dedicated in the spring of 1992 and is the hub of cocurricular activities at the University and a home away from home for our students. A variety of functions and services are provided at the center.

Staff at the **Welcome Center** in the main lobby offer a list of campus activities, guide guests and students to their destinations, sell snacks, provide a list of campus clubs and organizations, and in general, assist you with any problem you may encounter.

Dining facilities for the University are located in the University Center. Breakfast, lunch, and

dinner are served, as well as a wide variety of a la carte items. A main dining area and the Internet Café are provided for the convenience of diners. The Bears' Den Cafeteria is open from 7:30 a.m. to 7:00 p.m., Monday through Thursday; 7:30 a.m. to 6:00 p.m., Friday; 11:00 a.m. to 6:00 p.m., Saturday; and 5:00 to 6:00 p.m. on Sunday. A banquet room/study room, located on the second floor, is used for workshops, conferences, meetings, and any activity where food is served.

Two **student lounges** are provided for relaxing or studying. The Micklethwaite Lounge, on the first floor, is warmed by a copper-clad fireplace. The second floor Baxter Lounge has a disklavier player piano and two TV rooms and is located near the Micklethwaite Banquet Hall and three conference rooms.

A **game room** on the first floor has table tennis and pool tables, board games, cards, video games, a 70" big screen TV, and student mailboxes. Also, videos and athletic equipment can be checked out by currently enrolled students with valid IDs.

Located on the first floor of the University Center behind the cafeteria, the **Internet Café** connects users to the rest of the world via the Internet and e-mail. Students, staff, and visitors can grab a cup of coffee or a sandwich and "surf the net" in this comfortable coffeehouse environment.

Offices for Student Activities and Auxiliaries, Housing, Student Government Association, Student Programming Board, Greek Council, Residence Life Council, and other clubs and organizations are located on the first floor. The Offices of the Vice President for Student Affairs, the Registrar, Financial Aid, Career and Placement Services, Counseling and Psychological Services, and the Bursar are located on the second floor.

The building also has **ATM** and **postage stamp machines** for the convenience of students and staff. Copier service is available in the Office of Student Activities.

The University Center's hours of operation during the academic term are as follows:

Monday-Thursday	7:00 a.m. to 8:00 p.m.
Friday	7:00 a.m. to 6:00 p.m.
Saturday	11:00 a.m. to 6:00 p.m.
Sunday	5:00 p.m. to 6:00 p.m.

Hours during university breaks vary and are posted on the front door.

Housing and Residence Life

University Housing Policy

Shawnee State University is committed to the particular educational value that is provided by a residential campus community. The residential setting offers you an unparalleled opportunity to gain from the social interactions and other life experiences that characterize on-campus housing and dining.

As a condition of admission and continued enrollment, first-year students not living within a 50-mile radius of the University with their immediate families are required to live in University Housing, to the extent that space is available, and to take their meals in dining facilities as provided in meal plans approved by the University. Exceptions to this policy include married students, single parents, veterans, and students age 23 or older.

If you feel that you should be exempt from this requirement, you must submit a Housing Requirement Exemption Form to the Office of Student Activities and Auxiliaries. Exemptions may be granted to students who:

- Live and travel to class from the principal residence of their parent(s) or legal guardian(s) which is on the border line of the 50-mile radius or live (at no cost to the student) within the 50-mile radius with a direct relative. A direct relative is defined as a parent, grandparent, sibling, uncle, or aunt. (In some cases, a notarized letter from the relative may be required along with the exemption form.)
- Can demonstrate other acceptable extenuating circumstances.

For exemption forms or more information on exemptions, contact the Office of Student Activities and Auxiliaries. Nonexempt first-year students not residing on campus are considered in violation of this policy and may have their records placed on hold with the University, thus preventing future registration.

Living on Campus

The residence life experience is one you will remember for a lifetime, with lasting friendships, opportunities for involvement, and the chance to learn while living with others. Whether you are required to live on campus, or are simply looking at on-campus housing as an option, you will find that our convenience, service, security, and comfort make University Housing a great place to live!

Our apartments offer students an independent living style with residence life staff there to assure maximum safety and service. All of our apartment complexes are within minutes of any university building. Each apartment is furnished, and you will find many luxuries you would not expect in on-campus housing.

Throughout the year, staff offer many events for resident involvement. Previously, the activities have included such things as sand volleyball tournaments, dances, time management seminars, and alcohol education. We try to provide opportunities for students to socialize and take a look at the issues that face them.

On-Campus Dining

The Bears' Den cafeteria offers Shawnee State students the opportunity to have fresh, nutritionally sound meals in a community atmosphere. Our dining service features an appetizing menu that changes from day to day, a salad bar, a sub bar, and the ever-popular grill items, such as hamburgers, pizza, and fries, which are available every day.

For information on menu choices, visit our web page at www.shawnee.edu/student/food/index.html or call our dining hotline at 740.351.3150.

Shawnee State University offers meal plans to our housing students as well as those students who are commuting. For more information about food service, please contact the dining services manager at 740.351.3617.

Housing and Residence Life Information

Applications and contracts are issued for a three-quarter academic year or the remainder of the academic year in which the student applies.

For further information, contact the Office of Student Activities and Auxiliaries at:

Shawnee State University
940 Second Street
Portsmouth, Ohio 45662-4344
740.351.3217

The University Chronicle

The *University Chronicle*—Shawnee State University's official student newspaper—is packed full of news about the things that matter to SSU students, faculty, and staff. The *Chronicle* also

provides a great means through which students who are interested in journalism and/or communications-related careers can build a solid portfolio that will help them find jobs in the future.

The *University Chronicle* is always looking for reporters, photographers, advertising sales reps, and layout/design personnel. Some positions are paid, while others receive college credit. If you are interested in becoming a part of the *University Chronicle*, please contact Terry Hapney, M.A.J., faculty advisor, at 740.351.3112, or via e-mail at thapney@shawnee.edu.

The Alumni Association

The Shawnee State University Alumni Association is an ever-growing network of over 8,000 graduates of Shawnee State University and its predecessor institutions. The Alumni Association's main purposes include:

- Bringing together and improving communication between SSU alumni and friends;
- Providing a means through which SSU alumni and friends can actively participate in networking;
- Providing scholarship opportunities for the children of SSU alumni and other SSU students;
- Supporting the SSU mission by promoting volunteerism and assisting in development; and
- Working with the Office of Admission and the Student Success Center to help recruit and retain students.

Join the SSU Alumni Association

Shawnee State University hopes, upon graduation from the University, you will become an active member of the SSU Alumni Association.

Dues are not required; however, when alumni or friends of SSU make a contribution to the SSU Annual Fund, they become active members of the SSU Alumni Association.

Membership includes:

- A subscription to *Shawnee State Currents*—SSU's official quarterly publication;
- A membership card, SSU auto window decal, and SSU key chain;
- Information on SSU events;
- SSU Clark Memorial Library card;
- Special discounts on SSU merchandise and in university activities;
- Athletics ticket opportunities; and

- Chances to win tickets to events at the SSU Vern Riffe Center for the Arts.

Honors and Awards

The Shawnee State Alumni Association awards the Silver Star Alumni Award to an outstanding SSU alumnus every May. This award is presented to a graduate of Shawnee State who has contributed time and effort in an exemplary manner to the University, promoted community service to improve the quality of life for residents in their community, participated actively in the Alumni Association, and been a Shawnee State alumnus for at least five years. To nominate someone for this honor, please send an e-mail message to alumni@shawnee.edu.

The SSU Alumni Association also awards the Alumnus of Tomorrow award during the month of May. This honor is presented to a Shawnee State student who graduates the following June, who has displayed commitment to their individual endeavors—academic, social, and personal. To nominate someone for this honor, please contact the Alumni Association at alumni@shawnee.edu.

If you are aware of an alumnus, student, faculty or staff member, or other friend of the University who has done something extraordinary or has received an honor or accomplished an important task which warrants media coverage, please contact the Office of Communications at Shawnee State. The Office produces a newsletter, *Shawnee State Currents*, for the friends of SSU—alumni, legislators, media, and donors, among others. The Office also directs complete photographic coverage of all SSU events and programs and sends news releases to local, regional, statewide, and national media.

Contact the Alumni Association

Terry L. Hapney, Jr., M.A.J., Director,
Communications and Alumni Relations

Shawnee State University
First Floor, Administration Building
940 Second Street
Portsmouth, Ohio 45662

740.351.3810 or 800.959.2SSU (hit "8" and ask for extension 3810)

Fax: 740.351.3179

E-mail: alumni@shawnee.edu
communications@shawnee.edu



ACADEMIC

PROGRAMS



Programs of Study

Bachelor of Arts

English/Humanities
 Communications
 Culture and Medial Studies
 General
 Integrated Language Arts with
 Adolescent to Young Adult
 (Grades 7-12) Licensure
 History
 International Relations
 Psychology
 Social Sciences
 Social Sciences
 Adolescent to Young Adult
 (Grades 7-12) Licensure,
 Integrated Social Studies
 Legal Assisting (2+2)
 Sociology

Bachelor of Fine Arts

Art Education
 Ceramics, Drawing, Painting
 Photography/Imaging
 Studio Arts
 Visualist Digital Design and
 Interactive Media

Bachelor of Individualized Studies

See pages 61 and 128 of the current catalog for description.

Bachelor of Science

Biology
 Business Administration
 Accounting
 General
 Health Management
 Legal Assisting (2+2)
 Management Information
 Systems
 Chemistry
 Computer Engineering Technology
 Education
 with Licensure in:
 Early Childhood (Grades PreK-3)
 Early Childhood Intervention
 Specialist (Grades PreK-3)

Middle Childhood (Grades 4-9)
 Multiage Intervention Specialist
 (K-12)
 Environmental Engineering
 Technology
 Mathematical Sciences
 Mathematical Sciences
 Integrated Mathematics with
 Adolescent to Young Adult
 (Grades 7-12) Licensure
 Natural Science
 Natural Science
 Earth Science, Life Science,
 Physical Science or Integrated
 Science, with Adolescent to
 Young Adult (Grades 7-12)
 Licensure
 Mathematics
 Mathematics and Science with
 Middle Childhood (Grades 4-9)
 Licensure
 Nursing (RN-BSN)
 Occupational Therapy
 Plastics Engineering Technology
 Sports Studies
 Athletic Training
 Fitness Development
 Sports Management

Associate of Applied Business

Accounting Technology
 Business Information Systems
 Business Management Technology
 Legal Assisting Technology
 Office Administration Technology

Associate of Applied Science

Associate Degree Nursing
 Computer Aided Design
 Dental Hygiene
 Early Childhood Development
 with Pre-Kindergarten Associate
 Licensure
 Electromechanical Engineering
 Technology
 Emergency Medical Technology
 Medical Laboratory Technology
 Occupational Therapy Assistant
 Physical Therapist Assistant
 Plastics Engineering Technology
 Radiologic (X-ray) Technology
 Respiratory Therapy

Associate of Arts

Arts/Humanities
 Art
 Communications
 English
 General
 Music
 Social Science

Associate of Individualized Studies

See pages 64 and 129 of the current catalog for description.

Associate of Science

Mathematics
 Sciences

Certificates

Computer Aided Drafting and
 Design (CADD)
 Deaf Studies
 Emergency Medical Technology
 (EMT)
 Environmental Science
 Plastics Engineering Technology
 Web Engineering Technology

Other degrees and programs are in various stages of development and may be available before the next catalog is published. If you'd like more information, please call:

College of Arts and Sciences
 • 740.351.3554

College of Professional Studies
 • 740.351.3270

Office of Admission
 • 1.800.959.2SSU

General Education Program

All students studying toward a baccalaureate degree at Shawnee State are required to complete the University's General Education Program (GEP). This group of courses gives students the opportunity to acquire the characteristics of an educated person—something quite distinct from the goals of other courses associated with the degree programs offered by Shawnee State. Most courses required for a specific degree program are meant to give students the opportunity to study a particular discipline and the ability to practice a profession. The goal of Shawnee State University, however, goes beyond professional education to preparing you to function effectively in the multiple roles demanded by contemporary life. In this respect, the General Education Program supports the University's mission statement.

The GEP is a combination of required and elective courses, grouped in categories, each chosen for the contribution it makes to the skills or knowledge characteristic of university graduates.

For More Information

Robert Mauldin, Ph.D., Director

General Education Program
Shawnee State University
940 Second Street
Portsmouth, Ohio 45662-4344

Office Location: Vern Riffe Center for the Arts,
Room 313
Phone: 740.351.3137
Fax: 740.351.3501 (Provost's Office)
E-mail: rmauldin@shawnee.edu

Our Commitment to Your Success

Shawnee State's General Education Program is committed to:

- Providing an undergraduate education that includes competence in written communication, oral communication, scientific and quantitative reasoning, critical analysis, and logical thinking.

- Providing a breadth of knowledge that goes beyond education for a specific discipline or profession.
- Providing a breadth of experience that includes knowledge and understanding of multicultural factors.
- Ensuring that you have the ability to reflect carefully upon ethical issues and can enter into reasoned dialogue about these issues.
- Preparing you to become an independent and continuing learner.

As part of our commitment to the success of our students, Shawnee State University has adopted the goal of integrating information literacy and computer literacy into the courses included in the General Education Program.

General Education Program Requirements by Content Category

The GEP requirements are arranged in two levels. You should complete requirements at the Foundational Level before you take courses that satisfy the Integrative Level of the program. Also, it is suggested that you begin by taking courses in English and mathematics and continue to take courses in these areas until you have completed requirements in English composition and quantitative reasoning.

A more complete description of each category follows. Specific course descriptions are found in their own section of this catalog, beginning on page 183.

Foundational Level:

English Composition	12 Hours
Quantitative Reasoning	4 Hours
Fine and Performing Arts	4 Hours
Social Sciences	4 Hours
Natural Sciences	8 Hours

Integrative Level:

Cultural Perspectives	8 Hours
Ethics	4 Hours
Capstone	4 Hours

Total Hours Required **48 Hours**

Note: It should be noted that in cases where a single course meets requirements of the General Education Program and the major, the total number of hours required for the GEP will be reduced by

the number of related course hours. The minimum credit hours required for the baccalaureate degree shall not, however, be less than 186.

English Composition (12 Hours)

These courses provide an opportunity for you to develop as a writer. Their goal is for you to learn to write clearly, concisely, and creatively in a variety of formats.

☞ Take *all three* of the following courses:

- ENGL 111S¹ Discourse and Composition (4)
- ENGL 112S¹ Composition and Research (4)
- ENGL 115S¹ Composition and Literature (4)

Note: All three English composition courses must be completed prior to taking coursework at the Integrative Level of the GEP.

Quantitative Reasoning (4 Hours)

This component of the General Education Program addresses the nature of mathematical thought and its impact on modern life. To fulfill the quantitative reasoning component of the GEP, each course contains active communication about mathematics (which includes reading and/or writing and/or speaking), exercises designed to stimulate critical thinking, the use of mathematical-related technology, and an emphasis on problem solving. In addition, each course stresses data and data analysis, demonstrates the application of mathematics to a variety of disciplines, and incorporates activity-based learning.

☞ Choose *one course* from the following list:

- MATH 110S¹ Mathematics Core Course (4)
- MATH 131¹ Precalculus 1 (4)
- MATH 150 Principles of Statistics (4)
- MATH 170¹ Applied Finite Mathematics (4)
- MATH 190¹ Brief Calculus with Applications (4)
- MATH 201¹ Calculus 1 (4)
- MATH 220¹ Discrete Mathematics (4)
- MATH 250¹ Statistics 1 (4)

Fine and Performing Arts (4 Hours)

You should leave the GEP with a greater appreciation of how the arts contribute to an enriched quality of life. Courses in this category include either an art history, art appreciation, music, or theatre component.

☞ Choose *one course* from the following list:

- ARTH 101¹ Introduction to Art (4)
- ENGL 275¹ American Film History (4)
- MUSI 120¹ Introduction to Music Literature (4)
- MUSI 220¹ Music Literature (4)
- PHIL 300 Philosophy of Film (4)
- THAR 100¹ Introduction to Theatre (4)

Social Sciences (4 Hours)

This GEP component introduces you to the breadth and depth of the influence the social sciences have on contemporary life. Courses reflect an interdisciplinary or cross disciplinary approach with the expectation of increasing your awareness of the interconnectedness of the social sciences.

☞ Choose *one course* from the following list:

- ANTH 250¹ Principles of Cultural Anthropology (4)
- GEOG 130¹ Economic Geography (4)
- GOVT 250 Introduction to Political Science (4)
- GOVT 401 State of the World (4)
- HIST 410 Intellectual History 1 (4)
- HIST 411 Intellectual History 2 (4)
- PHIL 230 Social and Political Philosophy (4)
- SOCI 101¹ Introduction to Sociology (4)
- SOSC 110S¹ Foundations of Social Science (4)

Natural Sciences (8 Hours)

The natural science component of the General Education Program addresses scientific reasoning.

☞ Choose *one* of the following two options:

- OPTION 1** NTSC 110S, Scientific Reasoning and Methodology (4), and one additional natural science course from the following list (all include a laboratory component).
- BIOL 151¹ Principles of Biology (5)
 - BIOL 210 Taxon. of Vasc. Plants (4)
 - BIOL 271 Field Ornithology (4)
 - BIOL 302 Dendrology (4)
 - BIOL 303 Spring Flora (4)
 - BIOL 307 General Entomology (5)
 - CHEM 121¹ Intro. to Gen. Chem. 1 (4)
 - CHEM 141¹ General Chemistry 1 (5)
 - GEOL 111¹ Rocks/Minerals/Fossils (4)
 - GEOL 112¹ Environmental Geology (4)
 - GEOL 201¹ Physical Geology (4)
 - NTSC 372 Ohio's Natural Heritage (5)
 - PHYS 201¹ Physics 1 (Mechanics) (4)
 - PHYS 210¹ Astronomy (4)
 - PHYS 211¹ Calculus-Based Physics 1 (4)
 - PSCI 251 Phys. Sci. by Inquiry 1 (4)
 - PSCI 252 Phys. Sci. by Inquiry 2 (4)

¹ **Note to potential transfer students:** If you plan to transfer from Shawnee State to another state university in Ohio and you plan to complete the general education transfer module (described on page 19), you should select from these courses. Contact the GEP director, 740.351.3137, if you have any questions.

OPTION 2 A minimum of 12 credit hours in natural science courses (BIOL, CHEM, GEOL, NTSC, PHYS, PSCI) above 110, which includes at least one course of four credit hours or more with a laboratory component.

Note: Credit is not allowed for both CHEM 121/122 and CHEM 141/142.

Cultural Perspectives (8 Hours)

The goal of this GEP component is to help you understand aspects of western and non-western cultures and to appreciate the multicultural nature of modern society. Courses may vary as to discipline, content, and approach, but each instills some comprehension of the complex historical, cultural, or sociological contexts which inform contemporary experience.

☞ **Western Perspective:** *Choose one of the following two options:*

OPTION 1

Select one of the following courses pertaining to a western cultural perspective.

- IDST 225S¹ Civilization and Literature 1 (4)
- IDST 226S¹ Civilization and Literature 2 (4)
- PHIL 200¹ Introduction to Philosophy (4)

OPTION 2

Complete a one-year sequence (12 sequenced credit hours) of a western foreign language.

☞ **Non-Western Perspective:** *Choose one of the following two options:*

OPTION 1

Select one of the following courses pertaining to a non-western cultural perspective.

- ARTH 366 Non-Western Survey (4)
- GEOG 201¹ Cultural Geography (4)
- GEOG 351 Regional Geog. of the Middle East (4)
- GOVT 320 Third World Politics (4)
- GOVT 370 Global Politics (4)
- HIST 330 History of Southern Africa (4)
- HIST 360 East Asian History (4)
- HIST 371 Islamic Religion, Culture, & Civil. (4)
- HIST 420 Middle East in Modern Times (4)
- IDST 227S¹ Civilization and Literature 3 (4)
- PHIL 284 East Asian Philosophy (4)

OPTION 2

Complete a one-year sequence (12 sequenced credit hours) of a non-western foreign language.

Ethics (4 Hours)

The requirement in ethics serves several purposes within the GEP's broader goal of enabling students "to function effectively in the multiple roles demanded by contemporary life." First, students are introduced to the most influential moral theories of western civilization. These theories attempt to answer what constitutes the good life and what makes an action ethical, as well as introduce ways of reasoning about the moral life. Second, students learn how these theories affect how we think about public life, including the relationship of morality to law and public policy. Third, students engage in a thorough and careful analysis of contemporary moral issues in order to arrive at a rationally defensible, well-informed conclusion within a context of open and civil dialogue with others. Evaluation is based, first and foremost, on how well students reason about moral issues, not on the particular conclusions.

☞ Choose *one course* from the following list:

- PHIL 320S Ethics in Public and Private Life (4)
- PHIL 330 Ethics and Tech. in the 21st Century (4)
- PHIL 331 Business Ethics (4)
- ROCI 485S Reflect. on Community Involvement (4)

Capstone (4 Hours)

☞ **Senior Seminar (IDST 490S)** comes late in your university experience and gives you the opportunity to write, speak, think, analyze, synthesize, and integrate. A central part of the seminar is the research and writing of a major paper and an oral presentation of your findings.

¹ **Note to potential transfer students:** If you plan to transfer from Shawnee State to another state university in Ohio and you plan to complete the general education transfer module (described on page 19), you should select from these courses. Contact the GEP director, 740.351.3137, if you have any questions.



COLLEGE OF **ARTS**
& **SCIENCES**



College of Arts and Sciences

The overall mission of the College of Arts and Sciences is the liberal arts education and career preparation of Shawnee State students. Liberal arts education provides graduates with intellectual skills, substantive knowledge, and habits of the mind that promise rewarding careers and the more abundant life.

Courses provided by the College of Arts and Sciences contribute to your capability for abstract and systematic analysis and comprehension of the scientific method and encourage appreciation for and understanding of the varieties of artistic expression. These courses contribute to your flexibility, enabling you to see problems in a new light and to pursue alternative solutions. They also provide the communication and interpersonal skills essential for sharing these ideas in an increasingly collaborative and global workplace.

Liberal arts education at Shawnee State incorporates the teaching of these skills into a program that alerts you to the complexity of human history and diversity of cultures while exploring alternative approaches to contemporary social, economic, and political issues. Acknowledging the moral dimension of many of these questions, the liberal arts program explores ethical approaches and encourages you to develop a personal philosophy of life.

The University's commitment to liberal education begins with the College of Arts and Sciences' General Education Program, which emphasizes the importance of knowledge, values, and cultural enrichment. Building on the General Education Program, the College provides a spectrum of liberal arts degree programs in the arts and humanities, mathematics, the natural sciences, the social sciences, and teacher education. These degree programs prepare you for a career or successful matriculation into a graduate or professional degree program.

For More Information

Jerry G. Holt, Ph.D., Dean
Linda D. Plummer, B.A., Secretary
College of Arts and Sciences
Shawnee State University
940 Second Street
Portsmouth, Ohio 45662-4344

Phone: 740.351.3554
Fax: 740.351.3596
E-mail: jholt@shawnee.edu
lplummer@shawnee.edu

Programs Offered

Bachelor of Arts

English/Humanities, Communications
English/Humanities, Culture and Media Studies
English/Humanities, Generalist
English/Humanities, Integrated Language Arts with Adolescent to Young Adult (Grades 7-12) Licensure
History
International Relations
Psychology
Social Sciences
Social Sciences, Legal Assisting (2+2)
Social Sciences, Adolescent to Young Adult (Grades 7-12) Licensure, Integrated Social Studies
Sociology

Bachelor of Fine Arts

Art Education
Ceramics, Drawing, Painting
Photography/Imaging
Studio Arts
Visualist Digital Design & Interactive Media

Bachelor of Individualized Studies

See page 61 of current catalog for description.

Bachelor of Science

Biology
Chemistry
Mathematical Sciences
Mathematical Sciences, Integrated Mathematics with Adolescent to Young Adult (Grades 7-12) Licensure
Natural Science
Natural Science/Earth Science, Life Science, Physical Science, or Integrated Science with Adolescent to Young Adult (Grades 7-12) Licensure
Natural Science, Mathematics
Natural Science, Mathematics and Science with Middle Childhood (Grades 4-9) Licensure
Sports Studies
Athletic Training
Fitness Development
Sports Management

Bachelor of Science in Education

- Early Childhood Licensure (Grades PreK-3)
- Early Childhood Intervention Specialist Licensure (Grades PreK-3)
- Middle Childhood Licensure (Grades 4-9)
- Multiage Intervention Specialist Licensure (Grades K-12)

Minors

- American or British Literature
- Biology
- Chemistry
- Economics
- English Language and Linguistics
- Environmental Science
- Geography
- History
- Journalism
- Mathematical Sciences
- Music
- Philosophy
- Political Science
- Professional Writing
- Psychology
- Sociology
- Sport Coaching
- Teaching English to Speakers of Other Languages
- Theater

Associate of Arts

- Arts/Humanities, Arts
- Arts/Humanities, Communications
- Arts/Humanities, English
- Arts/Humanities, General
- Arts/Humanities, Music
- Social Science

Associate of Individualized Studies

See page 64 of current catalog for description.

Associate of Applied Science

- Early Childhood Development with Pre-Kindergarten Associate Licensure

Associate of Science

- Mathematics
- Sciences

Certificates

- Deaf Studies
- Environmental Science

Faculty: A Commitment to Teaching, Scholarship/Research and Creative Activities, and Service

The College of Arts and Sciences' faculty are dedicated and talented individuals. Their graduate degrees are from the finest universities in the world, and they care deeply about your personal growth and academic success. The outstanding talent and achievements of our alumni are due, in large part, to the high quality of teaching of the faculty.

Quality teaching is the primary emphasis of the College, and its faculty are dedicated to extending the frontiers of knowledge. To enrich their teaching, faculty are contributing to the body of significant research and scholarly work and creative activities in their disciplines as well as providing service to the community, region, state, and nation.

Accelerated Bachelor's Degree Programs

Baccalaureate degrees offered by the College of Arts and Sciences are planned in such a way that you can complete all requirements by taking classes during a twelve-quarter period, spread over four academic years. However, the requirements of some baccalaureate degrees make it possible for you to earn your degree in a shorter period of time.

To earn a degree in three years, you need to take classes in the summer and/or take 18 or more hours each quarter, with the permission of your department chairperson or dean and the registrar. Careful planning of your course schedule is necessary. If you are interested in pursuing a three-year degree program, you should talk to your faculty advisor to make sure that this option is possible.

For more information about an accelerated bachelor's degree, contact the appropriate department chairperson or the dean.

Selecting and Declaring a Degree Major

You should consider a choice of major and career early in your degree program, if not before. You are encouraged to seek the advice of College of Arts and Sciences faculty and, also, staff in the Office of Counseling and Career Services. Your

own interests, aptitudes, and professional/career goals should play a central role in selecting a degree major.

Double Major Guidelines

The completion of at least one major is required for a baccalaureate degree. The completion of a second major is an option which any College of Arts and Sciences student may elect. If you wish to pursue more than one major, you must consult with the appropriate department chairperson(s) or dean.

- The two majors must be in different subject matters.
- Each major must meet all the requirements set by the College of Arts and Sciences and the department offering the major.
- Each major must contain at least 45 hours not found in the other major.

Academic Advising

The College of Arts and Sciences is committed to quality academic advising, because it is essential to the ultimate success of our students. Once you have selected a major, you are advised by the teaching faculty of your department. Please consult your academic advisor regarding the two-year schedule for the department in order to determine when the department plans to offer specific courses. The chairperson of your department will assign you an academic faculty advisor, ensuring that the department's academic advising system meets your individual needs and requirements as well as those of the department, the College, and the University. The dean of the College of Arts and Sciences facilitates answers to interdepartmental questions and exceptions and changes to related academic requirements.

Baccalaureate Degree Requirements

The College of Arts and Sciences awards its baccalaureate degrees to students who meet the following minimum requirements. Please see individual degree programs for any additional requirements.

- A minimum of 186 credit hours, including 48 credit hours in the General Education Program.
- A minimum 2.00 cumulative grade point average for all courses taken at Shawnee State University.

- Completion of at least 90 credit hours at the 200 level or above.
- Completion of at least 45 credit hours at Shawnee State University, of which 35 credit hours must be the upper division courses (300-400 level courses).
- A minimum of 60 credit hours in the major field of study.
- Petition for graduation in accordance with the rules prescribed by the University.

Bachelor of Individualized Studies Degree (B.I.S.)

The bachelor of individualized studies is administered by the College of Arts and Sciences and the College of Professional Studies as appropriate. Students interested in a B.I.S. program should contact the dean of the college most closely associated with their field of study/interest.

The B.I.S. is intended for undergraduate students who wish to pursue an area of study (or combination of areas) which is not available in other academic programs at Shawnee State. The proposed course of study must not closely parallel programs already offered at the university. The desire to avoid certain specific requirements of existing majors or degree programs is not a sufficient justification for choosing a B.I.S. program.

This degree may be particularly useful to working students taking evening, weekend, or off-campus classes. Also, the B.I.S. may be used to combine the coursework from an associate degree program with an area of concentration from another field of study. For example, students completing an associate degree in one of the health sciences programs may elect to include an area of concentration in health management or business administration for a B.I.S. degree.

Students planning to pursue graduate or professional school degrees are advised to complete a traditional major at the undergraduate level rather than complete the B.I.S. degree.

Admission to the Bachelor of Individualized Studies

After admission to the University, a student makes an appointment for a conference with an individualized studies advisor. The student makes this appointment by contacting either the dean of the College of Arts and Sciences or the dean of the College of Professional Studies.

In this conference, the advisor will explore with the student the appropriateness of the bachelor of individualized study given his or her background and academic goals.

To obtain formal admission to the bachelor of individualized studies, the student must complete an application, which includes the following elements:

- A statement explaining that the student understands the nature and intent of the general studies major
- A statement of plans for future education and employment with the individualized studies major as a foundation
- A statement of the goals the proposed course of study will meet, an appropriately detailed outline of the proposed course of study, and a projected graduation date

The application for admission to the bachelor of individualized study will be reviewed by a three-person faculty advisory committee consisting of the student's faculty advisor and two faculty appointed by the appropriate college's dean. If the application and proposed course of study is approved by the advisory committee, these items will be forwarded to the appropriate dean for approval and the registration of these degree requirements by the registrar.

Advising

The student pursuing an individualized studies major is encouraged to seek academic advising each quarter.

Degree Requirements

The individualized studies major must meet and fulfill university requirements for baccalaureate programs and those requirements specific to this degree. These include:

- A minimum of 186 credit hours, including the General Education Program.
- A minimum of 2.00 cumulative grade point average for all courses taken at Shawnee State University.
- Completion of at least 45 credit hours of upper-division level (300-400 courses), no more than 10 hours of which may be transferred in from another accredited university or college.
- A minimum of 45 credit hours completed at Shawnee State. The University's general policies regarding the transferability of courses from other colleges and universities will apply equally to this major.

- A minimum of 60 credit hours in the individualized/specialized area of study and cognate areas, as approved by a three-member faculty committee.
- Completion of the specific program of study initially approved by the student's faculty advisory committee upon admission to the major. Any subsequent alterations in the program, including course substitutions, must receive the approval of the student's advisory committee.
- The completion of at least 45 credit hours after approval of student's program.
- Petition for graduation in accordance with the rule prescribed by the University.

Minors

A minor is a field of study, within the baccalaureate degree, that may be taken to widen your area of interest or increase your career opportunities. Contact specific departments for information regarding minor offerings and minor field of study course requirements. Taking a minor is optional and not required.

Associate of Arts and Associate of Science Degrees

The College of Arts and Sciences offers several programs of study which lead to two-year associate degrees. The associate degree programs allow you to enter the job market immediately after you graduate or to transfer into certain baccalaureate degree programs.

In order to ease the transfer process, the following associate of arts and associate of science degree requirements will be modified to include a revised transfer module. Therefore, if you wish to pursue either degree, you are advised to work closely with an advisor during this transition period.

Associate of Arts Degree

Curriculum

I. General Education Requirements

A. Composition — 12 hours minimum

ENGL 111S Discourse and Composition (4); ENGL 112S Composition and Research (4); ENGL 115S Composition and Literature (4)

Students may take additional courses from the following (optional): ENGL 232 (4); ENGL 240 (4); ENGL 245 (4)

- B. Mathematics — 4 hours minimum
MATH 110S Mathematics Core Course (4)
Students may choose additional mathematics courses from the following (optional): MATH 131 (4); MATH 132 (4); MATH 201 (4); MATH 202 (4); MATH 250 (4)
- C. Arts and Humanities — 16 hours minimum
IDST 225S Civilization and Literature (4)
and two courses from the following: ARTH 261 (4); ARTH 262 (4); ENGL 200 (4); MUSI 220 (3); PHIL 200 (4)
and one course from the following: ENGL 211 (4); ENGL 212 (4); MUSI 221 (3); MUSI 222 (3); MUSI 223 (3); PHIL 105 (4); PHIL 200 (4)
- D. Social Science — 16 hours minimum
SOSC 110S Foundations of Social Science (4)
IDST 226S Civilization and Literature 2 (4)
and one course from the following: ECON 101 (4); GEOG 125 (4); GOVT 101 (4); HIST 111 (4); HIST 112 (4); HIST 113 (4); PSYC 101 (4); SOCI 101 (4)
and one course from the following: ANTH 101 (4); ANTH 250 (4); ECON 102 (4); GOVT 240 (4); GOVT 250 (4); HIST 201 (4); HIST 202 (4); HIST 203 (4); PSYC 151 (4); PSYC 273 (4); SOCI 201 (4); SOCI 205 (4)
- E. Natural Sciences — 12 hours minimum
NTSC 110S Scientific Reasoning & Methodology (4)
and 8 additional hours from the following: BIOL 151 (5) (4 lec./2 lab); CHEM 121 (4); CHEM 122 (4); CHEM 141 (5); CHEM 142 (5); CHEM 143 (5) (all CHEM - 3 lec./3 lab); GEOL 111 (4) (3 lec./2 lab); PHYS 201 (4); PHYS 202 (4); PHYS 203 (4) (all PHYS - 3 lec./3 lab)
Students may choose additional courses from the following (optional): BIOL 162 (5); BIOL 202 (5); BIOL 203 (5); CHEM 200 (4); GEOL 112 (4); PHYS 210 (4)
Note: Students cannot receive credit for both CHEM 121/122 and CHEM 141/142 series.
- II. Concentration Area — 30 hours
- A. Arts
Selected courses in an area of specialization chosen from the following list of humanities subject areas to complete the associate of arts degree:
- | | | |
|------------------|------------|------------|
| Art | Humanities | Music |
| Comparative Arts | Journalism | Philosophy |
| English | Language | Theatre |
- B. Social Sciences
Selected courses in an area of specialization chosen from the following list of subject areas to complete the associate of arts degree:
- | | | |
|--------------|------------|------------|
| Anthropology | Government | Psychology |
| Economics | History | Sociology |
| Geography | | |

Associate of Science Degree

Curriculum

- I. General Education Requirements
- A. Communications — 12 hours minimum
ENGL 111S Discourse and Composition (4); ENGL 112S Composition and Research (4); ENGL 115S Composition and Literature (4)
- B. Mathematics — 8 hours minimum
MATH 110S Mathematics Core Course (4)
and one additional course from the following: MATH 131 (4); MATH 132 (4); MATH 201 (4); MATH 202 (4); MATH 250 (4)
- C. Arts and Humanities — 12 hours minimum
ENGL/HIST 225S Civilization and Literature (4)
and two of the following: ARTH 261 (4); ARTH 262 (4); ENGL 200 (4); MUSI 220 (3); PHIL 200 (4)
Students may take additional courses from the following (optional): ENGL 211 (4); ENGL 212 (4); MUSI 221 (3); MUSI 222 (3); MUSI 223 (3); PHIL 105 (4); PHIL 200 (4)
- D. Social Sciences — 12 hours minimum
SOSC 110S Foundations of Social Science (4)
ENGL/HIST 226S Civilization and Literature 2 (4)
and one of the following: ECON 101 (4); GEOG 125 (4); GOVT 101 (4); HIST 111 (4); HIST 112 (4); HIST 113 (4); PSYC 101 (4); SOCI 101 (4)
- E. Natural Sciences — 16 hours minimum
NTSC 110S Scientific Reasoning & Methodology (4)
and 12 additional hours chosen from the following: BIOL 151 (5) (4 lec./2 lab); CHEM 121 (4); CHEM 122 (4); CHEM 141 (5); CHEM 142 (5); CHEM 143 (5) (all CHEM - 3 lec./3 lab); GEOL 101 (4) (3 lec./2 lab); PHYS 201 (4); PHYS 202 (4); PHYS 203 (4) (all PHYS - 3 lec./3 lab)
Students may take additional courses from the following (optional): BIOL 162 (5); BIOL 202 (5); BIOL 203 (5); CHEM 200 (4); GEOL 112 (4); PHYS 210 (4)
Note: Students cannot receive credit for both CHEM 121/122 and CHEM 141/142 series.
- II. Concentration Area — 30 hours
- A. Science
Selected courses in an area of specialization chosen from one of the following subject areas:
Biology
Physical Science (includes chemistry, geology, physics, and physical science)
- B. Mathematical Sciences
- Selected courses from mathematics — 22 hours minimum must be numbered above 110.
 - Science — 8 hours minimum must be chosen from biology, chemistry, geology, or physics numbered above 100.

Associate of Individualized Studies Degree (A.I.S.)

The associate of individualized studies degree (AIS) at Shawnee State University allows you to formulate your own individualized program of study based upon specific criteria. The goal of this degree is to permit the student, under the guidance of faculty advisors, to combine selected courses in academic and/or technical areas that may not meet the degree requirements for Shawnee State's associate of arts, associate of science, associate of applied science, or associate of applied business degrees.

The following conditions must be met for completion of the degree: 1) a total of 90 credit hours of 100-level or above coursework with a minimum grade point average of 2.00; 2) a minimum of two areas of concentration with at least 20 credit hours in each; 3) a set of minimum general education requirements as outlined below; and 4) completion of a minimum of 45 hours of credit after admission to the program.

The minimum set of general education requirements for the AIS is as follows:

- ENGL 111S and ENGL 112S (8 hours)
- One course at or above MATH 105 (4 hours)
- At least 12 hours from three different categories of the Foundational Level of the University's General Education Program, described on pp. 55-57. The Foundational Level includes the following categories: social sciences, natural sciences, English composition (ENGL 115S), and fine and performing arts.

Note: If you plan to transfer to another state university in Ohio in order to pursue a four-year degree program, you should consider completing the general education transfer module as outlined on page 19 of this catalog.

For specific details and application forms for the program, contact the dean's office in the College of Arts and Sciences or the dean's office in the College of Professional Studies.

Preparation for Teacher Licensure

Programs to prepare teachers at several different levels and in a variety of teaching areas are offered cooperatively between the Department of Teacher Education and the Departments of English and

Humanities; Fine, Digital, and Performing Arts; Mathematical Sciences; Natural Sciences; and Social Sciences. At the early childhood level (grades preK-3) a degree in education is offered. At the middle childhood level (grades 4-9), a degree in education or natural science is available. Licensure at the adolescent to young adult level (grades 7-12) requires a degree in the area of teaching specialization. Multiage licenses (grades K-12) in visual arts and intervention specialist are also available.

If you wish to become a licensed teacher, you should consult the Department of Teacher Education section of this catalog and work with a faculty advisor on licensure matters. In addition to completing the related B.A. or B.S. degree requirements, you must complete the professional education requirements and other eligibility criteria for teacher licensure.

Course Scheduling and Offerings

The College of Arts and Sciences is committed to scheduling daytime classes, introductory and upper level, in a way that allows you to complete a degree program in a four-year period of time. As staffing permits, occasional upper division classes from the various arts and sciences disciplines are offered in the evenings. At this time, no arts and sciences degree program can be earned in the evenings over a five-year period. However, it may be possible to earn an associate of individualized studies degree in the evenings. Also, we are planning to offer a baccalaureate degree with a major in individualized studies that may be available through evening studies in the near future. You are encouraged to discuss specific course scheduling issues with your academic advisor or your department chairperson.

Pass/No-Credit Policy

Students in the College of Arts and Sciences are not permitted to take courses in their major on a pass/no-credit basis.

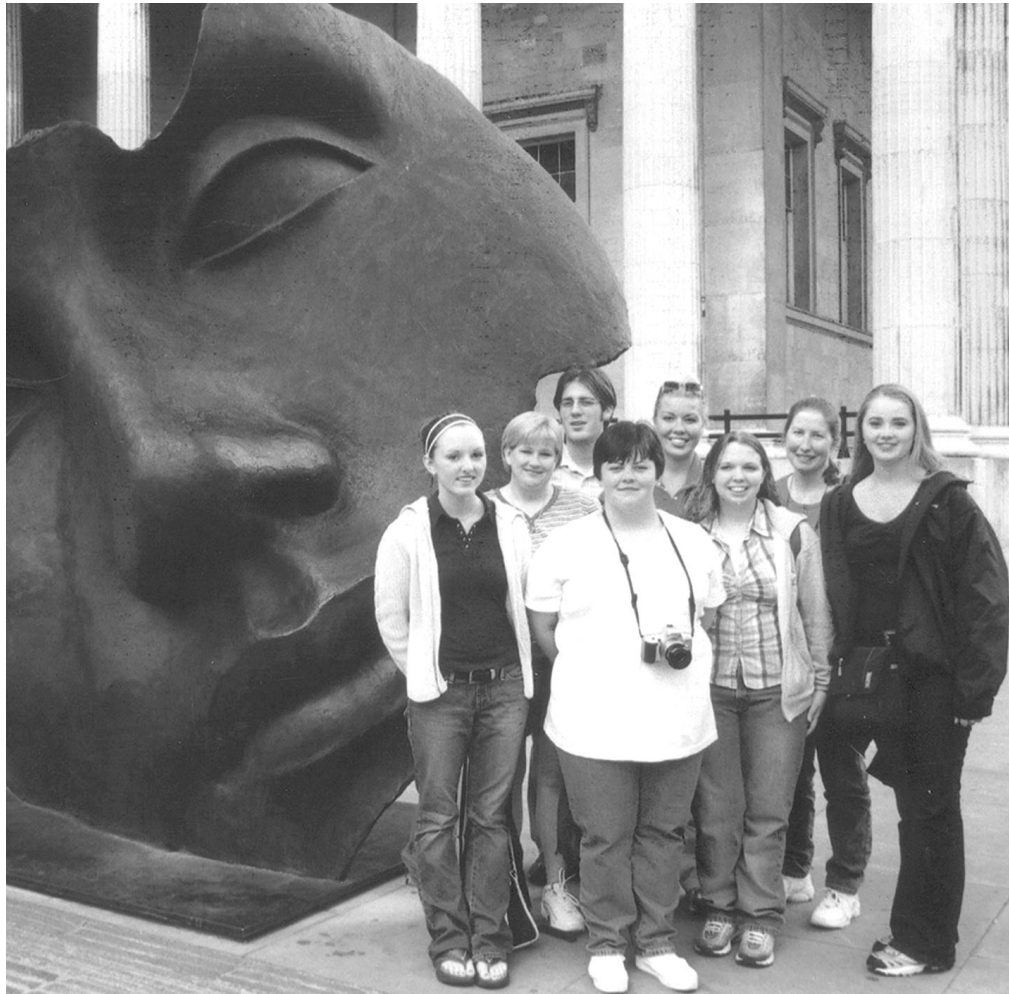

ENGLISH &
HUMANITIES

English and Humanities

The faculty of the Department of English and Humanities develop students who think and read critically, who write and speak clearly, and who understand the contributions humanities courses can make to their knowledge and quality of life. The faculty believe that the skills of reading, writing, speaking, and thinking are the foundations upon which a successful college career is built. Therefore, all disciplines within the Department accept as part of their charge the development of writing and speaking skills. In addition, the faculty are committed to providing opportunities for the integration of the disciplines and the fostering of international and multicultural perspectives.

The Department offers excellent opportunities for students to study introductory and advanced courses in linguistics, foreign language, literature, philosophy, and writing.

For More Information

Timothy E. Scheurer, Ph.D., Chairperson
Elsie M. Shabazz, Secretary

Department of English and Humanities
Shawnee State University
940 Second Street
Portsmouth, Ohio 45662-4344

Phone: 740.351.3300

Fax: 740.351.3584

E-mail: eshabazz@shawnee.edu

Programs in Humanities

Bachelor of Arts

English/Humanities, Communications
English/Humanities, Culture and Media Studies
English/Humanities, Generalist
English/Humanities, Integrated Language Arts
with Adolescent to Young Adult (Grades
7-12) Licensure

Bachelor of Individualized Studies

See page 61 of current catalog for description.

Minors

American or British Literature
English Language and Linguistics

Journalism
Philosophy
Professional Writing
Teaching English to Speakers of Other Languages

Associate of Arts

Arts/Humanities, Communications
Arts/Humanities, English
Arts/Humanities, General
See page 62 of current catalog for degree
requirements.

Associate of Individualized Studies

See page 64 of current catalog for description.

Composition/Foreign Language Labs

The Department of English and Humanities maintains three classrooms/computer labs in Massie Hall for the teaching of composition and foreign language. They support faculty's efforts to use modern technology in their teaching.

The English Sequence

Students who must take the English sequence (English 111S, 112S, and 115S) are required to take a placement exam. See explanations on page 26 about placement.

Bachelor Degrees

The bachelor of arts degree with a major in English/humanities offers you the opportunity to pursue a degree with teaching or without teaching licensure.

The English/humanities degree (generalist) provides an excellent background for several career paths, including advertising, government employment, law, and publishing. The degree requires 186 hours, including 70 hours of electives. This distribution of required and elective courses allows you to pursue approved minors or to take a grouping of courses in such fields as science or business, which adds to your employment possibilities. The department strongly recommends that if you plan to attend graduate school, you should take courses in foreign language as well as additional courses in English, linguistics, and philosophy.

The English/humanities degree (communication concentration) is an excellent option for you if you wish to pursue a career in journalism, corporate

communication, publishing, public relations, editing, or media criticism. The degree requires 187 hours, including 47 hours in the communication core, 8 hours in the professional core, and 16 hours of electives that can be taken in writing, media visualist, or film and media areas.

The English/humanities degree (culture and media studies concentration), like the English/humanities generalist degree, prepares you for a variety of careers, ranging from teaching to government to law. It is an excellent option for students wishing to pursue masters or doctoral studies in the field of English and/or cultural studies. The degree requires 188 hours, including 48 in the cultural studies core and 24 hours of electives that can be taken in areas as diverse as history, sociology, political science, psychology, business, music, art, and philosophy.

The bachelor of arts in English/humanities, integrated language arts with adolescent to young adult licensure (grades 7-12) combines education and English/humanities classes to prepare teachers for grades 7 through 12. At a time when a national teaching shortage has become apparent, this degree offers good opportunities for employment.

With both degrees in English and humanities, classes are relatively small and students receive much individual attention from well-qualified and dedicated teachers.

As with any degree at the University, the Department of English and Humanities very much encourages students to work closely with their faculty advisor. The department secretary (740.351.3300) can easily provide the names of advisors for individual students.

Important Note About Student Assessment

The English and Humanities Department is very much aware of the national movement that encourages assessment of student learning. Students majoring in English and humanities should submit papers for their writing assessment portfolio, which is kept by the department secretary. The portfolio includes a major paper from ENGL 200 and three other upper-division English courses. The final submission is the Senior Seminar paper (required of all four-year degree students). The English and humanities faculty review these portfolios after students apply for graduation to assess if students have made sufficient progress as writers and students of literature. Additionally, students must maintain a C average in all ENGL courses.

Bachelor of Arts with a Major in English/Humanities (Generalist)

Degree Requirements

General Education Program	48 Hours
<i>Further information is listed on page 55 of the current catalog or can be obtained from the dean's office.</i>	
English/Humanities Courses	68 Hours
<i>(Includes 20-hour elective block, of which 4 hours must be above the 300 level.)</i>	
Electives <i>(Note: At least 24 hours of these electives must be from 300 and 400 level courses. The Department strongly recommends that you take specialized courses in one or two areas. Foreign language is an excellent area of specialization for English/humanities majors.)</i>	70 Hours
Total Hours Required	186 Hours

English/Humanities Courses (68 Hours)

Area	Cr. Hrs.
Philosophy (PHIL 105 or 200)	4
Introduction to Literature (ENGL 200)	4
Linguistics (ENGL 360, 362, 365, 452, or 455 or ENGL 460)	8
Survey of Literature (ENGL 211, 212, 251, or 252)	8
Shakespeare (ENGL 301 or 302)	4
Adv. Composition Requirement (ENGL 305 or 315)	4
British Literature Before 1800 (ENGL 311, 411, 421, and other suitable courses)	4
British Literature After 1800 (ENGL 312, 321, 322, 441, 446, and other suitable courses)	4
American Literature (ENGL 273, 351, 371, 461, 471, and other suitable courses)	4
Literature as Social Perspective (ENGL 205, 249, 340, 341, 342, 343, 344, and other suitable courses)	4
Humanities Electives (Courses must be taken in at least two areas with four hours at the 300 level or higher)	20
Art History	Philosophy
Music History	Linguistics (one additional course)
Foreign Language	Other suitable courses as added

Bachelor of Arts with a Major in English/Humanities (Communications)

Degree Requirements

General Education Program	48 Hours
<i>Further information is listed on page 55 of the current catalog or can be obtained from the dean's office.</i>	
English/Humanities Courses	68 Hours
<i>(Includes 20-hour elective block, of which 4 hours must be above the 300 level.) See list of courses above.</i>	
Communication Core	47 Hours
Professional Core	8 Hours
Electives	16 Hours
Total Hours Required	187 Hours

Communication Core (47 hrs.)

Course No.	Course	Cr. Hrs.
ARTS 106	Digital Foundations	4
ARTS 361	Digital Publishing & Layout	4
ENGL 306	Professional Writing	4
ENGL 335	Interpersonal Communication	4
ENGL 392	Intercultural Communication	4
ENGL 490	Management Communication	4
JOUR 105	Intro. to Mass Communication	4
JOUR 231	News Reporting & Writing	4
SPCH 103	Public Speaking & Human Comm.	3
XXX	Foreign Language Electives	12

Professional Core (8 hrs.)

BUMG 101	Introduction to Business	4
BUMK 310	Marketing	4

Electives (16 hrs.)

Courses may be taken from the following areas:

WRITING

ENGL 240	Screenwriting	4
ENGL 245	Creative Writing	4
ENGL 305	Creative Nonfiction	4
JOUR 289	Magazine Feature Writing	4
JOUR 295	Journalism Practicum	4
JOUR 395	Practicum 2	4

MEDIA VISUALIST PRODUCTION

ARTS 210	Photography	4
ARTS 251	Typography for the Graphic Designer	4
ARTS 313	Media Photography	4
ARTS 362	Digital Imaging	4
ARTS 399	Digital Video	4

FILM, RADIO AND TV

ARTS 210	Photography 1	4
ARTS 399	Digital Video	4
ENGL 240	Screenwriting	4
ENGL 275	American Film History	4
ENGL 480	Popular Culture & the Mass Media	4
PHIL 300	Philosophy & Film	4
THAR 100	Introduction to Theater	4
THAR 332	Theater History	4

Bachelor of Arts with a Major in English/Humanities (Culture and Media Studies)

Degree Requirements

General Education Program	48 Hours
<i>Further information is listed on page 55 of the current catalog or can be obtained from the dean's office.</i>	
English/Humanities Courses <i>(Includes 20-hour elective block, of which 4 hours must be above the 300 level.) See list of courses on previous page.</i>	68 Hours
Cultural Studies Core	48 Hours
Electives	24 Hours
Total Hours Required	188 Hours

Cultural Studies Core (47 hrs.)

Course No.	Course	Cr. Hrs.
ANTH 250	Prin. of Cult. Anthropology <i>OR</i>	4
SOCI 320	Sociology of Culture	
ENGL 205	Introduction to Women's Studies	4
ENGL 280	Introduction to American Studies 1	4
ENGL 281	Introduction to American Studies 2	4
ENGL 381	Fundamentals of Criticism	4
ENGL 385	Cultural Studies: Theory & Methods	4
ENGL 485	Senior Experience in English	4
JOUR 105	Intro. to Mass Communication	4
PHIL 200	Introduction to Philosophy	4
XXX	Foreign Language Electives	12

Bachelor of Arts in English/ Humanities, Integrated Language Arts with Adolescent to Young Adult (Grades 7-12) Licensure

Degree Requirements

General Education Program	48 Hours
<i>PHIL 320S and THAR 100 are required. Further information is listed on page 55 of the current catalog or can be obtained from the Department of Teacher Education.</i>	
Language Arts Component	76 Hours
Professional Education Core	20 Hours
Reading/Literature Require.	8 Hours
Related Studies Component	12 Hours
Adolescent/Young Adult Courses	32 Hours
Total Hours Required	196 Hours

Language Arts Component (76 Hours)**LANGUAGE EMPHASIS (8 Hours)**

Course No.	Course	Cr. Hrs.
ENGL 360	Intro to Language & Linguistics	4
ENGL 362	Patterns of English	4

READING EMPHASIS (24 Hours)

ENGL 200	Introduction to Literature	4
ENGL 211	Survey of English Literature 1	4
ENGL 212	Survey of English Literature 2	4
ENGL 251	Survey of American Literature 1	4
ENGL 252	Survey of American Literature 2	4
ENGL 301	Shakespeare 1 <i>OR</i>	4
ENGL 302	Shakespeare 2	

Select two (8 hours):

ENGL 205	Introduction to Women's Studies	4
ENGL 249	Native American Literature	4
ENGL 340	Literature of the Americas	4
ENGL 341	Literature of Initiation & Experience	4
ENGL 342	Women in Literature	4
ENGL 343	Black Authors	4
ENGL 344	Literature of Appalachia	4

Select one (4 hours):

ENGL 311	Major English Authors (Before 1800)	4
ENGL 321	The English Novel	4

ENGL 322	Modern English Drama	4
ENGL 411	16th Century Renaissance Literature	4
ENGL 421	17th Century Poetry & Prose	4
ENGL 441	The Romantics	4
ENGL 446	The Victorians	4

WRITING EMPHASIS (12 Hours)

ENGL 305	Creative Nonfiction OR	4
ENGL 315	Theory & Practice in Composition	4
ENGL 232	Creative Writing (Poetry) OR	4
ENGL 240	Screenwriting OR	4
ENGL 245	Creative Writing (Fiction)	4
JOUR 231	News Reporting & Writing	4

LISTENING/VISUAL LITERACY EMPHASIS (9 Hours)

ENGL 105	Information Access	1
JOUR 105	Intro. to Mass Communication	4
PHIL 105	Rhetoric & Reasoning	4

ORAL COMMUNICATION EMPHASIS (7 Hours)

SPCH 103	Public Speaking & Human Comm.	3
SPCH 220	Oral Interpretation of Literature	4

CAPSTONE (4 Hours)

ENGL 485	Sr. Exp. for English/Hum. Majors	4
----------	----------------------------------	---

Professional Education Core (20 Hours)

EDUC 115	Intro. to the Teaching Profession	4
EDUC 230	Instructional Media, Technology, & Computers	4
EDUC 240	School & Society: Legal, Theoretical, Philosophical, & Ethical Found. of American Education	4
EDUC 245	Teaching Individuals in a Pluralistic Society	4
EDUC 310	Strategies of Assessment, Diagnosis, & Evaluation in the Classroom	4

Reading/Literature Requirement (8 Hours)

EDRE 305	Teaching Reading in the Content Areas	4
ENGL 323	Adolescent Literature	4

Related Studies Component (12 Hours)

PSYC 101	Introduction to Psychology	4
PSYC 304	Psychology of Learning OR	4
PSYC 375	Educational Psychology	4
PSYC 312	Adolescent Psychology	4

Adolescent/Young Adult Courses (32 Hours)

EDAE 285	Practicum & Seminar 1: Observation & Reflection in Professional Practice	4
EDAE 385	Pract. & Sem. 2: Action Research - Home, School, & Comm. Relations	4
EDAE 400	Prin. & Strategies of Curriculum Develop., Mgt., & Instruction	4
EDAE 485	Practicum & Seminar 3: Curriculum, Instruction, & Evaluation	4
EDAE 490	Directed Teaching & Seminar	12
ENGL 434	Methods of Teaching Language Arts in the Secondary Schools	4

Special Note: The middle childhood license to teach language arts and English in grades 4-9 is found on pages 112 and 113 of this catalog.

Minors

The Department of English and Humanities currently offers minors in the areas of American or British literature, English language and linguistics, journalism, philosophy, teaching English to speakers of foreign languages (TESOL), and professional writing. Students wishing to concentrate their elective possibilities in these areas are advised to follow the suggested curricula.

American or British Literature

This minor allows students to concentrate their coursework on either American or British literature. The introductory classes are required to provide students with an introduction to literary developments important to either American or British literature. Students build on those introductory courses by selecting four courses of individual interest.

Minor in British Literature (24 Hours):

- ENGL 211 and 212 required
- Students select four courses in British literature at the 300 level or above.

Minor in American Literature (24 Hours):

- ENGL 251 and 252 required
- Students select four courses in American literature at the 300 level or above.

English Language and Linguistics

This minor requires you to complete 24 credit hours of English and linguistics. Courses emphasize the English language; however, other languages and language processes are covered primarily from a linguistics perspective. The 12 credits, which are mandatory, deal with introductory aspects of language and cover different core areas of the English language and language in general.

Requirements

The following three courses are required (12 credit hours):

ENGL 360	Introduction to Language and Linguistics
ENGL 362	Patterns of English
ENGL 365	History of English

Select three courses (12 credit hours) from the following list. Students may choose either GEOG 201 or ANTH 250 but not both since these courses do not exclusively deal with language.

ENGL 452	Language Acquisition
ENGL 455	English Language in Society
ENGL 460	Topics in Linguistics
GEOG 201	Cultural Geography <i>OR</i>
ANTH 250	Principles of Cultural Anthropology

Other courses will be added as they become available.

Journalism

The 31-hour minor in journalism offers you the opportunity to get a basic understanding of journalistic writing and procedures. You are encouraged to make practical application of your coursework.

Course No.	Course	Cr. Hrs.
ARTS 313	Media Photography	4
ARTS 361	Digital Publishing & Layout	4
ENGL 105	Information Access	1
ENGL 221	English in the Workplace	4
ENGL 305	Creative Nonfiction	4
JOUR 105	Intro. to Mass Communications	4
JOUR 231	News & Report Writing	4
JOUR 289	Magazine Feature Writing	4
JOUR 295	Practicum (<i>may be taken 3 times for credit</i>)	2
JOUR 395	Practicum (<i>may be taken 3 times for credit</i>)	2

Recommended:

SPCH 103	Public Speaking & Human Comm.	3
----------	-------------------------------	---

Philosophy

The study of philosophy enhances your baccalaureate degree program by providing you with a fuller understanding of the presuppositions of your discipline. Philosophy also strengthens your ability to think critically, to develop and defend arguments rationally, and to understand the logical, intellectual, and historical relationships among the various academic disciplines. In addition, you gain an understanding of the profound influence of philosophical ideas upon society, culture, and politics, which in turn greatly enhances your ability to work in multicultural settings.

Careers for which the minor in philosophy is especially well-suited include law and public service, education, social services, religious ministry, counseling psychology, the arts, journalism, and international relations.

The minor requires students to complete 24 hours in philosophy with a minimum grade of "C." Courses taken on a pass/no credit basis may not be applied to the minor.

Requirements

Course No.	Course	Cr. Hrs.
PHIL 105	Rhetoric & Reasoning	4
PHIL 200	Introduction to Philosophy	4

Choose 12 hours from the following:

PHIL 230	Social & Political Philosophy	4
PHIL 260	Philosophy of Religion	4
PHIL 284	East Asian Philosophy	4
PHIL 299	Special Topics in Philosophy	4
PHIL 300	Philosophy & Film	4
PHIL 340	Philosophy of Sport	4
PHIL 499	Special Topics in Philosophy	4

Choose 4 hours from the following:

PHIL 320S	Ethics in Public & Private Life	4
PHIL 330	Ethical Tech. in the 21st Century	4
ROCI 485S	Reflections on Comm. Involvement	4

Professional Writing

This minor is an excellent addition to any degree program, particularly those in the natural and social sciences and in professional studies programs. Because it develops and refines the writing skills needed by professionals in all fields, this minor makes a graduate attractive to prospective employers. Courses in technical, business/administrative, expository, and journalistic modes of writing develop in students a high level of professional writing competency. A total of 28 hours are required.

Requirements

Course No.	Course	Cr. Hrs.
ENGL 121	Technical Writing 1	4
ENGL 221	English in the Workplace	4
ENGL 222	Business Writing	4
ENGL 305	Creative Nonfiction	4
ENGL 306	Professional Writing	4

Choose one from the following:

BUOA 221	Word Processing 1	4
BUOA 222	Word Processing 2	4
BUOA 223	Word Processing 3	4
BUOA 230	Desktop Publishing 1	4
BUOA 231	Desktop Publishing 2	4

Choose one from the following:

JOUR 231	News Writing	4
JOUR 289	Magazine Feature Writing	4

Teaching English to Speakers of Other Languages (TESOL)

This minor is a free-standing program within the Department of Arts and Humanities, although it also provides part of the coursework necessary for licensure within the state of Ohio in the area

of TESOL. To complete the minor, 28 credit hours of coursework are required as listed below, with five additional courses recommended. For details regarding TESOL licensure within the state of Ohio, see the Department of Teacher Education.

Required Courses

SPAN 111 Elementary Spanish 1
SPAN 112 Elementary Spanish 2
SPAN 113 Elementary Spanish 3

or a minimum of three quarters of coursework in any first year foreign language sequence.

ENGL 360 Introduction to Language and Linguistics
ENGL 362 Patterns of English
ENGL 455 English Language in Society
ENGL 460 Topics in Linguistics: Methods of Teaching ESL

Recommended Courses

SPAN 211 Intermediate Spanish 1
SPAN 212 Intermediate Spanish 2
SPAN 213 Intermediate Spanish 3

or any second-year sequence of foreign language courses.

EDUC 245 Teaching Individuals in a Pluralistic Society
(Preq. EDUC 110)
EDUC 450 Directed Teaching and Seminar
(Preq. admission to the teacher education program and admission to student teaching)



FINE,
DIGITAL &
PERFORMING **ARTS**

Fine, Digital, & Performing Arts

The faculty of the Department of Fine, Digital, and Performing Arts help guide students' skills, talents, and understanding to expand their artistic/expressive abilities and world views. The faculty believe that the process of acquiring a balanced perspective facilitates your understanding of who you are as an individual, which forms the core of your artistic and academic growth. We encourage your artistic growth in traditional arts and performing skills as well as cutting-edge technologies, realizing that there are many paths and definitions to artistic and performing success. We furthermore encourage you to develop the necessary skills in writing, speaking, and movement to facilitate additional avenues of expression in a world which is rapidly becoming more dependent upon communications at many levels. It is our guiding principle that students in the department come to an understanding of, and sensitivity to, how their talents, skills, and acumen progress and serve the artistic, aesthetic, and design needs of an increasingly complex multicultural, multinational world.

The Department offers excellent opportunities for you to study introductory and advanced courses in drawing, painting, printmaking, photography, digital design, ceramics, sculpture, art history, music, and theater.

For More Information

Thomas D. Stead, M.F.A., Chair
 Djwana Spradlin, Secretary
 Dpt. of Fine, Digital, and Performing Arts
 Shawnee State University
 940 Second Street
 Portsmouth, Ohio 45662-4344
 Phone: 740.351.3118
 Fax: 740.351.3418
 E-mail: tstead@shawnee.edu
dspradlin@shawnee.edu

Programs in Fine, Digital, and Performing Arts

Bachelor of Fine Arts

Art Education
 Ceramics, Drawing, Painting

Photography/Imaging
 Studio Arts
 Visualist Digital Design & Interactive Media

Bachelor of Individualized Studies

See page 61 of current catalog for description.

Minors

Music
 Theater

Associate of Arts

Arts/Humanities, Art
 Arts/Humanities, Music
 See page 62 of current catalog for degree requirements.

Associate of Individualized Studies

See page 64 of current catalog for description.

Vern Riffe Center for the Arts

Shawnee State University's BFA programs are located in the \$17 million, 102,000 sq. ft., Vern Riffe Center for the Arts. Art studios, comprising some 29 rooms with dramatic natural and artificial lighting, fill most of the east wing of the building. The first floor houses both the Levi Ceramics Suite and the photography suite. The 14 rooms in these two areas, as in the other studios throughout the Center, are equipped with state of the art equipment. The second floor houses the Appleton Gallery, Richards Virtual Reality Multimedia Studio, art education, drawing, and two computer studios. The computer studios are high level Mac-Intosh-based studios for the use of students in all the arts. The multimedia studio has digital projection in many formats, surround sound, and one of only two infinite baffle speaker systems in the world. The third floor has studios for painting, life studies, design and illustration, fabric design/screen printing, lithography, and intaglio printmaking. The music wing contains seven practice studios, an electronic keyboard lab, and an ensemble room. The Center also houses the Howland Recital Hall, the Kahl Black Box Theater, and an acoustically variable 1139 seat concert hall/theater.

Bachelor Degrees

Bachelor of Fine Arts Degree

The bachelor of fine arts is recognized as the professional degree in the arts field. Shawnee State

University offers this degree with several concentrations: art education, ceramics, drawing, painting, photography/imaging, studio arts, and visualist digital design and interactive media.

The learning experience is enhanced by the Vern Riffe Center for the Arts, a state-of-the-art facility that houses the BFA classes and features north-facing walls of windows in nearly every studio. These studios offer the latest in lighting, equipment, safety, and ventilation as well as access for physically challenged students. The academic programs based in the Center offer creative students a wide range of possible career opportunities, many employing high-end, cutting-edge technical equipment and computers.

The BFA and the professional portfolios developed through the program may well lead the successful candidate to career opportunities in teaching, studio work (ceramics, drawing, painting), photography/imaging, digital design work (print, web, or interactive), digital video, museum curation, corporate curation, or the opportunity to pursue a masters degree (in order to acquire college teaching credentials).

The Department is currently developing a BFA with a concentration in game and simulation development arts in cooperation with the Department of Industrial and Engineering Technologies. Pending final approval, the concentration will enable the successful graduate to gain entry into what is said to be the fastest growing segment of the entertainment industry, as game sales continue to exceed all US film box office earnings for another consecutive year. The process incorporates drawing, theater, writing, animation, advanced programming, math, physics, and many other skillsets. For information concerning this degree program and its status, contact the Department of Fine, Digital, and Performing Arts.

Open Enrollment

Shawnee State is an open-enrollment university in many of its degree programs. While most of our BFA programs require no portfolio or testing, it should be noted that programs such as the visualist digital design and interactive media and the proposed game and simulation design arts may at some point become limited entry.

Program Descriptions

- **Art Education** Multi-age visual arts licensure (PreK-12) is a program to educate art teachers.

The successful candidate may teach high school art or may be an arts specialist or supervisor in the elementary or middle school. This licensure does not qualify one to be a general elementary or middle school teacher. This program is purposefully “wide” in scope as we feel these teachers should be competent to cover a wide range of arts teaching categories. The art education licensure program adheres to the standards set forth by NCATE (National Council for the Accreditation of Teacher Education) and Ohio Department of Education Rule 3301-24-02. It also meets the guidelines of the State Competency Arts Education Model in the field of visual arts.

- **Ceramics** Shawnee State has developed an excellent program in ceramics. Our graduates have been offered MFA scholarships at schools such as Alfred University. A well equipped six-room studio suite with state-of-the-art kilns, 20 potter’s wheels, and other equipment and great faculty are the envy of many larger schools.
- **Drawing** There are few programs with a concentration in drawing. Drawing is the heart of most studio arts. We encourage and expect the development of high level skills in this most core 2-D discipline, which is an excellent precursor to graduate school.
- **Painting** There is something about painting that you never experience in any other medium. The color, texture, feel, and experience of the paint is unique. Preparation for both figurative and non-figurative work is encouraged. The development of a coherent portfolio of work is important.
Our third floor painting studio has both an inside area with 25-foot high north facing windows and an outdoor deck for good-weather painting.
- **Photography/Imaging** Photography is knowing/learning in a different, more acute way, what you are seeing when you look through that viewfinder or screen and then knowing the exact moment to fire the shutter. We have 20 enlargers in our 3 darkrooms and a large shoot studio with the latest in strobe lighting. Our computer studio is equipped with high-end computers and Adobe Photoshop™ for imaging software development.
- **Studio Arts** Studio arts is a program designed to accommodate those students who want to pursue a more general studio degree. It allows for focus on two areas of studio work.

■ **Visualist Digital Design & Interactive Media**

Print design, web design, and animation are part of this unique program. The visualist concentration treats the computer as a complete design environment. The digital arts software of today erases and blends many of the previous design paradigms and works toward reorganizing them into a nearly single field of expertise. Our design students may elect one of two tracks through the program. The imaging track focuses the student more toward manipulating and manufacturing images while the design track covers graphic design and illustration concepts. This program provides students with many time-on task opportunities with over 200 classroom hours on the computers using programs such as Photoshop, Freehand, Quark X-Press, and others.

Incoming Tech Prep students must become a part of the assessment sample for this program (see department secretary).

General Education Program (GEP)

All bachelor's degree students take the GEP. It should be noted, though, that in cases where a single course meets requirements of the General Education Program and the major, the total number of hours required for the GEP will be reduced by the number of related course hours. The minimum credit hours required for the baccalaureate degree shall not, however, be less than 186.

Art Core Requirements (44 Hours)

Required of all BFA students.

Course No.	Course	Cr. Hrs.
ARTH 261	Art History Survey 1	4
ARTH 262	Art History Survey 2	4
ARTH 263	Art History Survey 3	4
ARTH XXX	Art History Electives (<i>Choose from ARTH 310, 331, 332, 360, 361, 364, or 366. Art education students are required to select ARTH 366 as one of their electives. This course also satisfies the Non-Western Cultural Perspectives component of the GEP and results in the waiving of 4 hours of the GEP requirement for art education students.</i>)	8
ARTS 101	Studio Foundations 1	4
ARTS 102	Studio Foundations 2	4
ARTS 103	Studio Foundations 3	4
ARTS 105	The Creative Process	4
ARTS 480	Senior Studio 1	4
ARTS 481	Senior Studio 2	4

Special Note: Students in any College of Arts and Sciences bachelor degree program must complete 60 credit hours at the 300 level or above. A minimum of 12 credit hours in the chosen emphasis must be at the 300 level or above. A maximum of nine credit hours of "topics in art" classes may be credited toward the emphasis. An additional four credit hours of topics may be credited toward the studio elective.

Degree Requirements for the Bachelor of Fine Arts, Art Education

This program combines extensive work in a number of visual arts areas with a license to teach art in grades PreK-12. Because it combines two programs, it may take longer to complete than a non-license BFA.

General Education Program (48 Hours)	44 Hours
<i>The Non-Western Cultural Perspectives component of the GEP is satisfied by a requirement in the major. Further information is listed on page 55 of the current catalog or can be obtained from the Department of Fine, Digital, and Performing Arts.</i>	
Art Core Requirements	44 Hours
<i>See left column this page.</i>	
Art Emphasis Area	32 Hours
<i>Choose 32 hours within either ceramics, drawing and printmaking, painting, photography/imaging, (page 77) or visualist digital design and interactive media (page 77).</i>	
Professional Education Core	20 Hours
Reading Requirement	4 Hours
Related Studies Component	12 Hours
Visual Arts Ed. Component	36 Hours
Art Studio Electives	24 Hours
Total Hours Required	216 Hours

Professional Education Core (20 Hours)

Course No.	Course	Cr. Hrs.
EDUC 115	Intro. to the Teaching Profession	4
EDUC 230	Instructional Media, Technology, & Computers	4
EDUC 240	School & Society: Legal, Theoretical Philosophical, & Ethical Found. of American Education	4
EDUC 245	Teaching Individuals in a Pluralistic Society	4
EDUC 310	Strategies of Assessment, Diagnosis, & Evaluation in the Classroom	4

Reading/Literature Requirement (4 Hours)

EDRE 305	Teaching Reading in the Content Areas	4
----------	---------------------------------------	---

Related Studies Component (12 Hours)

PSYC 101	Introduction to Psychology	4
PSYC 151	Human Growth & Development	4
PSYC 304	Psychology of Learning OR	4
PSYC 375	Educational Psychology	

Visual Arts Education Component (36 Hours)

Course No.	Course	Cr. Hrs.
ARTP 401	Studio Methods for Early Childhood Education	4
ARTP 402	Studio Methods for Middle Childhood Education	4
ARTP 403	Studio Methods for Adolescent to Young Adult Education	4
EDVA 285	Pract. & Sem. 1: Observation & Reflection in Professional Practice	4
EDVA 385	Pract. & Sem. 2: Action Research - Home, School, & Comm. Relations	4
EDVA 485	Practicum & Seminar 3: Curriculum, Instruction, & Evaluation	4
EDVA 490	Directed & Teaching Seminar	12

Art Studio Electives (24 Hours)

Choose at least one course from each area outside studio emphasis.

CERAMICS (4 HOURS)

ARTS 231	Ceramics 1	4
ARTS 232	Ceramics 2	4
ARTS 233	Ceramics 3	4

DIGITAL ARTS (4 HOURS)

ARTS 106	Digital Foundations	4
ARTS 362	Digital Imaging 2	4
ARTS 363	Digital Illustration/Type 2	4

DRAWING (4 HOURS)

ARTS 271	Life Drawing 1	4
ARTS 272	Life Drawing 2	4
ARTS 273	Life Drawing 3	4
ARTS 275	Drawing 1	4
ARTS 276	Drawing 2	4
ARTS 277	Drawing 3	4

PAINTING (4 HOURS)

ARTS 221	Painting 1	4
ARTS 222	Painting 2	4
ARTS 223	Painting 3	4

PHOTOGRAPHY (4 HOURS)

ARTS 210	Photography 1	4
ARTS 211	Photography 2	4
ARTS 212	Photography 3	4

PRINTMAKING (4 HOURS)

ARTS 244	Introduction to Printmaking	4
ARTS 245	Intaglio	4
ARTS 246	Lithography	4
ARTS 247	Screen Printing	4
ARTS 248	Relief Printing	4

SCULPTURE (4 HOURS)

ARTS 241	Sculpture 1	4
ARTS 242	Sculpture 2	4
ARTS 243	Sculpture 3	4

Special Note: The middle childhood license to teach language arts and English in grades 4-9 is found on pages 112 and 113 of this catalog.

Degree Requirements for the Bachelor of Fine Arts in Ceramics, Drawing, Painting, and Photography/Imaging

These studio concentrations prepare students for graduate programs and studio entrepreneurship. These programs are designed to bring individuals in a BFA program to a high level of both skill and thought in specific studio areas. Many of our students go on for advanced degrees in their studio area. College teaching positions in the arts require a terminal degree (MFA / 2 to 3 yrs.) while other teachers usually need to work toward an MA (1 yr.). Other students may wish to involve themselves in the arts-based business world of galleries, ceramics businesses, public sculpture, or photography/imaging studios. We encourage these students to take business courses to better prepare themselves for success.

General Education Program	48 Hours
<i>Further information is listed on page 55 of the current catalog or can be obtained from the dean's office.</i>	
Art Core Requirements See page 75.	44 Hours
Art Specialization (<i>Choose either ceramics drawing, painting, or photography/imaging.</i>)	40 Hours
Art Studio Electives (<i>Chosen from ARTS, ARTG, or ARTM outside art specialization</i>)	38 Hours
General Electives (<i>Chosen from courses other than ARTH, ARTS, ARTG, ARTM, ARTP</i>)	16 Hours
Total Hours Required	186 Hours

Degree Requirements for the Bachelor of Fine Arts in Studio Arts

General Education Program	48 Hours
<i>Further information is listed on page 55 of the current catalog or can be obtained from the dean's office.</i>	
Art Core Requirements See page 75.	44 Hours
Studio Emphasis (<i>Choose either ceramics drawing, painting, or photography/imaging.</i>)	32 Hours
Art Studio Electives (<i>Chosen from ARTS, ARTG, or ARTM outside art specialization</i>)	46 Hours
General Electives (<i>Chosen from courses other than ARTH, ARTS, ARTG, ARTM, ARTP</i>)	16 Hours
Total Hours Required	186 Hours

Studio Emphasis/Art Specialization (40 Hours)

Choose either a ceramics, drawing, painting, or photography/imaging emphasis.

CERAMICS

Course No.	Course	Cr. Hrs.
ARTS 231	Ceramics 1	4
ARTS 232	Ceramics 2	4
ARTS 233	Ceramics 3	4

ARTS 331	Intermediate Ceramics 1	4
ARTS 332	Intermediate Ceramics 2	4
ARTS 333	Intermediate Ceramics 3	4
ARTS 334	Raku Ceramics	4
ARTS 335	Porcelain Ceramics	4
ARTS 336	Glaze Theory & Practice	4
ARTS 338	Mold Making	4
ARTS 434	Advanced Raku	4
ARTS 435	Advanced Porcelain	4
ARTS 436	Advanced Glaze Theory & Practice	4

DRAWING AND PRINTMAKING

ARTS 244	Introduction to Printmaking	4
ARTS 245	Intaglio	4
ARTS 246	Lithography	4
ARTS 247	Screen Printing	4
ARTS 248	Relief Printing	4
ARTS 252	Illustration	4
ARTS 253	Advanced Illustration	4
ARTS 271	Life Drawing 1	4
ARTS 272	Life Drawing 2	4
ARTS 273	Life Drawing 3	4
ARTS 275	Drawing 1	4
ARTS 276	Drawing 2	4
ARTS 277	Drawing 3	4
ARTS 371	Intermediate Life Drawing 1	4
ARTS 372	Intermediate Life Drawing 2	4
ARTS 373	Intermediate Life Drawing 3	4
ARTS 375	Intermediate Drawing 1	4
ARTS 376	Intermediate Drawing 2	4
ARTS 475	Advanced Drawing 1	4
ARTS 476	Advanced Drawing 2	4

PHOTOGRAPHY / IMAGING

ARTS 210	Photography 1	4
ARTS 211	Photography 2	4
ARTS 212	Photography 3	4
ARTS 215	Photography /Graphic Design	4
ARTS 310	Intermediate Photography 1	4
ARTS 311	Intermediate Photography 2	4
ARTS 312	Intermediate Photography 3	4
ARTS 313	Media Photography	4
ARTS 362	Digital Imaging	4
ARTS 410	Advanced Photography 1	4
ARTS 410	Advanced Photography 1	4
ARTS 410	Advanced Photography 1	4

PAINTING

ARTS 221	Painting 1	4
ARTS 222	Painting 2	4
ARTS 223	Painting 3	4
ARTS 321	Intermediate Painting 1	4
ARTS 322	Intermediate Painting 2	4
ARTS 323	Intermediate Painting 3	4
ARTS 324	Watercolor 1	4
ARTS 325	Watercolor 2	4
ARTS 326	Watercolor 3	4
ARTS 327	Figure Painting 1	4
ARTS 328	Figure Painting 2	4
ARTS 329	Figure Painting 3	4
ARTS 421	Advanced Painting 1	4
ARTS 422	Advanced Painting 2	4
ARTS 423	Advanced Painting 3	4
ARTS 424	Advanced Watercolor 1	4
ARTS 425	Advanced Watercolor 2	4

ARTS 426	Advanced Watercolor 3	4
ARTS 427	Advanced Figure Painting 1	4
ARTS 428	Advanced Figure Painting 2	4
ARTS 429	Advanced Figure Painting 3	4

Degree Requirements for the Bachelor of Fine Arts, Visualist Digital Design and Interactive Media

General Education Program	48 Hours
<i>Further information is listed on page 55 of the current catalog or can be obtained from the dean's office.</i>	
Art Core Requirements <i>See page 75.</i>	44 Hours
Art Specialization <i>Choose design or imaging tracks</i>	52 Hours
Art Studio Electives <i>(16 hours may be chosen from ARTG or ARTS courses outside concentration)</i>	40 Hours
General Electives	16 Hours
Total Hours Required	200 Hours

Junior Portfolio Review *Students wishing to choose this concentration may be asked—as a class, with a year notice—to submit a portfolio to be admitted into the junior year (100 quarter hours) of this concentration, due to space constraints. This portfolio will be reviewed by a committee comprised of the digital arts faculty. Only those students who pass the portfolio review will be permitted to continue in the program. Students who do not pass this review may apply their credits toward one of the other art concentrations if they so desire.*

Co-op/Internship *Students may choose to initiate a co-op/internship (ARTS 459, 12 hours) in a professional graphics/imaging/interactive media business. The internship must be approved by the Department of Fine, Digital, & Performing Arts chairperson and it must agree with certain specifications and the review process. There is a department brochure describing everyone's role in the process, a copy of which must be given to the student's supervisor at the business along with internship evaluation forms.*

Art Specialization (52 Hours)

Course No.	Course	Cr. Hrs.
ARTS 251	Typography for the Graphic Designer	4
ARTS 355	Visualist Studio 1	4
ARTS 356	Visualist Studio 2	4
ARTS 357	Visualist Studio 3	4
ARTS 455	Visualist Studio 4	4
ARTS 456	Visualist Studio 5	4
ARTS 457	Visualist Studio 6 or	4
ARTS 459	Arts Internship <i>(may be taken in place of ARTS 455, 456, & 457)</i>	

Choose either the design or imaging track.

DESIGN TRACK

ARTS 106	Digital Foundations	4
ARTS 221	Painting 1	4
ARTS 252	Basic Illustration	4
ARTS 253	Illustration	4
ARTS 271	Life Drawing 1	4
ARTS 275	Drawing 1	4

IMAGING TRACK

Course No.	Course	Cr. Hrs.
ARTS 106	Digital Foundations	4
ARTS 210	Photography 1	4
ARTS 211	Photography 2	4
ARTS 212	Photography 3	4
ARTS 310	Intermediate Photography 1	4
ARTS 311	Intermediate Photography 2	4

Art Studio Electives (40 Hours)

Choose three from:

ARTS 361	Publishing/Layout	4
ARTS 362	Digital Imaging	4
ARTS 363	Digital Illustration/Type	4
ARTS 364	Digital Paint	4

Choose three from (check prerequisites):

ARTS 361	Publishing/Layout	4
ARTS 362	Imaging	4
ARTS 363	Digital Illustration/Type	4
ARTS 364	Digital Paint	4
ARTS 465	Digital 3-D	4
ARTS 466	Interactive Scripting	4
ARTS 467	Website Arts	4
	Electives Choose from any ARTS or ARTG courses.	16

Minors

Music

The music minor requires students to complete a minimum of 31 credit hours. You may choose to continue applied and ensemble courses beyond the minor requirements. The combination of both required and chosen music courses represents a coherent music program that includes theory, history, training, and performance.

Requirements

Course No.	Course	Cr. Hrs.
MUSI 101	Music Theory 1	3
MUSI 102	Music Theory 2	3
MUSI 103	Music Theory 3	3
MUSI 105	Ear Training & Sight Singing	3
MUSI 220	Music Literature	4
<i>Choose one from the following:</i>		
MUSI 221	Music History & Literature 1	3
MUSI 222	Music History & Literature 2	3
MUSI 223	Music History & Literature 3	3
MUSI 225	Country & Appal. Music History	4
<i>Choose one from the following:</i>		
MUSI 185	Vocal Ensemble (2 cr. hr. x 3 qtrs.)	6
MUSI 186	Instrumental Ensemble	6

Choose one area or a combination of two for six quarters from the following:

MUSI 370	Applied Voice (1 cr. hr. x 6 qtrs.)	6
MUSI 371	Applied Piano	6
MUSI 372	Applied Organ	6
MUSI 373	Applied Woodwind	6
MUSI 374	Applied Brass	6

Theater

Students enrolled in any of the University's baccalaureate degree programs may elect to complete a minor in theater. The theater minor is an independent program within the Department of Fine, Digital, and Performing Arts. The student is required to complete six theater courses and a seventh course chosen from the upper level course offerings. Students must pass all courses with a minimum grade of C.

Required Courses

THAR 100	Introduction to Theater
THAR 120	Stagecraft: Scenery and Props
THAR 335	Practicum in Production

Choose four credits from the following:

THAR 299	Topics in Theater
THAR 331	Directing 1
THAR 499	Topics in Theater

Choose two from the following:

THAR 210	Acting 1
THAR 211	Acting 2
THAR 212	Acting 3

Upper Level Courses

Choose one from the following:

ENGL 301	Shakespeare 1
ENGL 302	Shakespeare 2
MUSI 230	Musical Theater
THAR 205	Theater Planning and Management
THAR 310	Scene Development
THAR 331	Directing 1
THAR 431	Directing 2
THAR 499	Special Topics in Theater

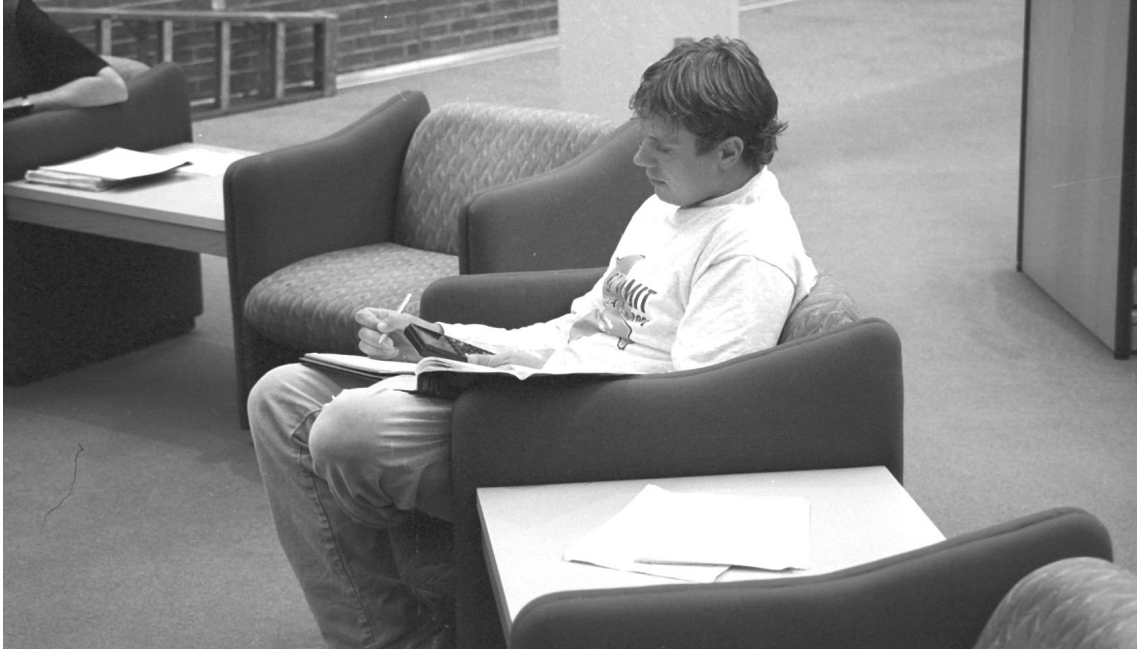

MATHEMATICAL SCIENCES



Mathematical Sciences

The Department of Mathematical Sciences provides Shawnee State's general education student with an appreciation of, and experiences with, the role of mathematics in our society. The Department also develops additional mathematical skills for those students whose academic programs require it and provides educational experiences for students who wish to specialize in mathematics.

In addition to close faculty-student working relations, the Department features an extensive tutoring program, use of technology in the curriculum, and modern student computing facilities.

The degrees offered by the Department of Mathematical Sciences provide a broad intellectual foundation in undergraduate mathematics, foster your reasoning and problem solving skills, and give you the opportunity to combine your interest in mathematics with preparation for a variety of career options.

Each of the Department's baccalaureate programs requires a senior research project which allows you to work closely with a team of faculty to study a mathematical topic in depth. The senior research project is designed to be an integrative and capstone experience and results in the development of a senior paper and presentation.

Each of the programs is described here in more detail. If you are interested in a degree in mathematics, you are encouraged to contact the Department at 740.351.3301 for additional information. Mathematical sciences faculty look forward to showing you what Shawnee State has to offer.

For More Information

Michael B. Fiske, Ph.D., Chairperson
 Carol Sexton, A.A.B., Secretary
 Department of Mathematical Sciences
 Shawnee State University
 940 Second Street
 Portsmouth, Ohio 45662-4344
 Phone: 740.351.3301
 Fax: 740.351.3584
 E-mail: csexton@shawnee.edu

Programs in Mathematical Sciences

Bachelor of Individualized Studies

See page 61 of current catalog for description.

Bachelor of Science

Mathematical Sciences
 Mathematical Sciences, Integrated Mathematics with Adolescent to Young Adult (Grades 7-12) Licensure
 Natural Science, Mathematics
 Natural Science, Mathematics and Science with Middle Childhood (Grades 4-9) Licensure

Minor in the Mathematical Sciences

Associate of Science

Mathematics
 See page 63 of current catalog for description

Associate of Individualized Studies

See page 64 of current catalog for description.

Bachelor Degrees

Bachelor of Science in Mathematical Sciences

This four-year program develops the analytical skills, knowledge base, and attitudes you need to use mathematics well and fosters your ability to learn mathematics and other technical material independently. Graduates of this program should be able to communicate technical concepts effectively and should have a solid understanding of the core subjects of undergraduate mathematics as well as some more specialized work at a more advanced level.

People with degrees in mathematical sciences enter a wide variety of professions, including careers in business and finance, computer science, law, industry, and education. The mathematical sciences major prepares you for careers in which analytic, problem solving, and quantitative skills are of central importance.

The study of mathematics is an appropriate foundation for the pursuit of a master's degree or doctorate degree in a variety of areas including business administration, computer science, economics, engineering, and law. Students from our program have entered graduate programs in biostatistics, computer science, education, mathematics, and meteorology.

The curriculum emphasizes the interdisciplinary nature of mathematics and its relationship to other disciplines as introduced by the general education program. The learning experiences gained in the liberal arts and science courses are used as a foundation upon which the mathematical sciences build and expand, showing that mathematics is not isolated but is part of an overall knowledge base. Students who major in the mathematical sciences are required, via the Connections Requirement, to take collateral coursework in fields that make use of mathematics, thus furthering the University's goal of tying career oriented education to a liberal arts foundation.

Degree Requirements

General Education Program	48 Hours
<i>Further information is listed on page 55 of the current catalog or can be obtained from the dean's office.</i>	
Mathematical Sciences Core	45 Hours
<i>If MATH 201, 220, or 250 is used to satisfy the GEP, 41 hours are required in the Mathematical Sciences Core and 69 hours are required in General Electives.</i>	
Upper Division Sequence	8 Hours
Mathematical Science Elective	4 Hours
<i>(Must be numbered 300 or higher.)</i>	
Computer Science Elective	4 Hours
Connections Requirement	12 Hours
General Electives	65 Hours
Total Hours Required	186 Hours

Mathematical Sciences Core (45 Hours)

All students completing a major in the mathematical sciences are required to take the following courses.

Course No.	Course	Cr. Hrs.
MATH 201	Calculus 1	4
MATH 202	Calculus 2	4
MATH 203	Calculus 3	4
MATH 204	Calculus 4	4
MATH 220	Discrete Mathematics	4
MATH 230	Linear Algebra	5
MATH 250	Statistics 1	4
MATH 301	Ordinary Differential Equations OR	4
MATH 430	Numerical Analysis	
MATH 360	Introduction to Probability	4
MATH 440	Mathematical Models OR	4
MATH 370	Operations Research 1	
MATH 496	Senior Research Project 1	1
MATH 497	Senior Research Project 2	2
MATH 498	Senior Research Project 3	1

Upper Division Sequence (8 Hours)

All students completing a major in the mathematical sciences are required to complete one of the following sequences:

MATH 410	Modern Algebra 1 AND	4
MATH 411	Modern Algebra 2 OR	4
MATH 335	Intermediate Analysis AND	
MATH 460	Real Analysis	

Computer Science Elective (4 Hours)

All students completing a major in the mathematical sciences are required to complete one of the following courses:

BUIS 103	Visual BASIC 1	4
BUIS 201	C Language	4
ETCO 115	VBASIC Computer Programming	4
ETCO 116	JAVA Computer Programming	4

Connections Requirement (12 Hours)

An important goal of our program is to assure that all students gain exposure to how the mathematical sciences are used. Through the Connections Requirement, you complete courses in a particular area, such as education, economics, business, computer science, engineering technology, or advanced specialized topics in the mathematical sciences. You are strongly encouraged to complete all of the courses in at least one of the strands. Some of the strands are designed to be comparable to minors.

All students completing a major in the mathematical sciences are required to complete one of the following strands.

BUSINESS STRAND

BUAC 201	Financial Accounting Principles
BUAC 203	Managerial Accounting
BUMG 235	Personnel Management
BULW 270	The Legal Environment of Business
BUFI 345	Managerial Finance
BUMG 310	Management Principles
BUMG 355	Quantitative Methods in Business
BUMG 385	Production/Operations Management
BUMK 310	Marketing Principles

COMPUTER SCIENCE STRAND

ETEC 102	Structured Programming with C
ETEC 103	Data Structures with C
ETEC 211	Assembly Language Programming 1
ETEC 275	Systems Programming
ETEC 280	Applications Programming
ETEC 371	Operating Systems 1
ETEC 372	Operating Systems 2
ETEC 373	Advanced Operating Systems
ETEC 408	Algorithms and Problem Solving
ETEC 477	Concurrency

ECONOMICS STRAND

ECON 201	Principles of Microeconomics
ECON 202	Principles of Macroeconomics
ECON 301	Intermediate Microeconomics
ECON 302	Intermediate Macroeconomics
ECON 310	Money and Banking
ECON 332	Managerial Economics
ECON 425	Public Finance
ECON 480	Econometrics

PHYSICS STRAND

PHYS 211	Calculus-Based Physics 1
PHYS 212	Calculus-Based Physics 2
PHYS 213	Calculus-Based Physics 3

GRADUATE SCHOOL PREPARATORY STRAND

MATH 410	Modern Algebra 1 AND
MATH 411	Modern Algebra 2 OR
MATH 335	Intermediate Analysis AND
MATH 460	Real Analysis

(whichever of the above sequences is not being used to satisfy the upper division sequence requirement)

MATH 450	Complex Variables
MATH 480	General Topology

SECONDARY MATHEMATICS EDUCATION STRAND

MATH 300	History of Mathematics
MATH 320	Foundations of Geometry
MATH 405	Math. Enrich. for the Secondary Teacher
MATH 470	Secondary Mathematics Methods

INDUSTRIAL MANAGEMENT AND STATISTICAL PROCESS CONTROL STRAND

ETPL 235	Statistical Processes/Quality Control 1
ETPL 335	Statistical Processes/Quality Control 2
ETPL 435	Statistical Processes/Quality Control 3
MATH 370	Operations Research 1
MATH 371	Operations Research 2
BUMG 355	Quantitative Methods in Business
BUMG 385	Production/Operations Management

Bachelor of Science in Mathematical Sciences, Integrated Mathematics with Adolescent to Young Adult (Grades 7-12) Licensure

This option within the bachelor of science in mathematical sciences program prepares you to be a teacher at the secondary level. Graduates have a broad background in the core of undergraduate mathematics and a firm foundation in professional education coursework, together with a strong general education component.

Students in this program are strongly encouraged to meet, on a regular basis, with an advisor from

both the Department of Mathematical Sciences and the Department of Teacher Education.

Degree Requirements

General Education Program (48 Hours)	44 Hours
<i>The Quantitative Reasoning component of the GEP is satisfied by the requirements of the bachelor of science in mathematical sciences. See page 55 for further information about the GEP.</i>	
Integrated Math Component	65 Hours
Professional Education Core	20 Hours
Reading/Literature Requirement	8 Hours
Related Studies Component	16 Hours
Adolescent/Young Adult Courses	32 Hours
General Elective	1 Hour
Total Hours Required	186 Hours

Integrated Math Component (65 Hours)

Course No.	Course	Cr. Hrs.
MATH 201	Calculus 1	4
MATH 202	Calculus 2	4
MATH 203	Calculus 3	4
MATH 204	Calculus 4	4
MATH 220	Discrete Mathematics	4
MATH 230	Linear Algebra	5
MATH 250	Statistics 1	4
MATH 300	History of Mathematics	4
MATH 301	Ordinary Differential Equations OR	4
MATH 430	Numerical Analysis	4
MATH 320	Foundations of Geometry	4
MATH 360	Introduction to Probability	4
MATH 405	Math. Enrich. for the Sec. Teacher	4
MATH 410	Modern Algebra 1	4
MATH 411	Modern Algebra 2	4
MATH 440	Mathematical Models OR	4
MATH 370	Operations Research 1	4
MATH 496	Senior Research Project 1	1
MATH 497	Senior Research Project 2	2
MATH 498	Senior Research Project 3	1

Professional Education Core (20 Hours)

EDUC 115	Intro. to the Teaching Profession	4
EDUC 230	Instructional Media, Technology, & Computers	4
EDUC 240	School & Society: Legal, Theoretical Philosophical, & Ethical Found. of American Education	4
EDUC 245	Teaching Individuals in a Pluralistic Society	4
EDUC 310	Strategies of Assessment, Diagnosis, & Evaluation in the Classroom	4

Reading/Literature Requirement (8 Hours)

EDRE 305	Teaching Reading in the Content Areas	4
ENGL 323	Adolescent Literature	4

Related Studies Component (16 Hours)

BUIS/ETCO	Computer Science Elective See page 81.	4
PSYC 101	Introduction to Psychology	4

PSYC 304	Psychology of Learning <i>OR</i>	4
PSYC 375	Educational Psychology	4
PSYC 312	Adolescent Psychology	4

Adolescent/Young Adult Courses (32 Hours)

EDAE 285	Practicum & Seminar 1: Observation & Reflection in Professional Practice	4
EDAE 385	Pract. & Sem. 2: Action Research - Home, School, & Comm. Relations	4
EDAE 400	Prin. & Strategies of Curriculum Develop., Mgt., & Instruction	4
EDAE 485	Practicum & Seminar 3: Curricu., Research, & Evaluation	4
EDAE 490	Directed Teaching & Seminar	12
MATH 470	Teaching Mathematics in Grades 7-12	4

Bachelor of Science in Natural Science, Mathematics

Shawnee State's bachelor of science in natural science degree program introduces you to a wide range of basic science disciplines and allows you to concentrate on one specific area. By selecting mathematics as the primary area of concentration, you may complete the requirements for the bachelor of science in natural science.

A number of career alternatives are available to students who complete this degree, including positions in government or industry that require quantitative competency and continued specialization in graduate school.

Degree Requirements

General Education Program	48 Hours
<i>Further information is listed on page 55 of the current catalog or can be obtained from the dean's office.</i>	
Concentration Area 1 <i>Mathematics courses numbered higher than MATH 130 to include MATH 201, 202, 496, 497, 498, and a least 12 hours at the 300-400 level. MATH 201 may not be used to satisfy both the GEP and the Concentration Area 1 requirements.</i>	44 Hours
Concentration Area 2 <i>Biology, chemistry, geology, or physics courses (select one area) numbered higher than 110</i>	16 Hours
Concentration Area 3 <i>Biology, chemistry, geology, or physics courses (selected from area other than Concentration Area 2) numbered higher than 110</i>	8 Hours
Humanities/Social Science Electives	24 Hours
<i>From at least two areas</i>	
Computer Science Elective <i>Select from BUIS 103, 201, ETCO 115, or 116</i>	4 Hours
General Electives	45 Hours
Total Hours Required	189 Hours

Note: A minimum of 35 hours must be at the 300 level or above.

Bachelor of Science in Natural Science, Mathematics and Science with Middle Childhood (Grades 4-9) Licensure

Students pursuing the middle childhood license to teach mathematics and science may select from one of two degrees. In addition to this bachelor of science in natural science, a bachelor of science in education is available. See pages 112 and 113 of this catalog. Consult with advisors from science, mathematics, or education to discuss which option best meets your needs.

This option is designed to prepare middle school professionals specializing in the teaching of mathematics and science.

Students in this program are strongly encouraged to meet, on a regular basis, with an advisor from the Department of Mathematical Sciences, the Department of Natural Sciences, and the Department of Teacher Education.

Degree Requirements

General Education Program (48 Hours)	36 Hours
<i>The Quantitative Reasoning and Natural Science components of the GEP (4 and 8 hours, respectively) are satisfied by the requirements of the bachelor of science in natural science. See page 55 for further information about the GEP.</i>	
Content Component	85-89 Hours
Professional Education Core	20 Hours
<i>See page 82 of current catalog.</i>	
Reading/Literature Requirement	18 Hours
Middle Childhood (Math. & Science)	36 Hours
Related Studies Component	16 Hours
Minimum Hours Required	211-215 Hours

Content Component (85-89 Hours)

MATHEMATICS (44-45 HOURS)		
Course No.	Course	Cr. Hrs.
MATH 110S	Mathematics Core Course	4
MATH 140	Elementary Topics in Math. 1	4
MATH 141	Elementary Topics in Math. 2	4
MATH 300	History of Mathematics	4
MATH 305	Math. Enrichment for the Teacher	4
MATH 320	Foundations of Geometry	4
MATH 496	Senior Research Project 1	1
MATH 497	Senior Research Project 2	2
MATH 498	Senior Research Project 3	1

Select one pair of the following courses:

Course No.	Course	Cr. Hrs.
MATH 132	Precalculus 2	4
MATH 190	Brief Calculus with Applications	4
<i>or</i>		
MATH 201	Calculus 1	4
MATH 202	Calculus 2	4

Select one of the following:

MATH 150	Principles of Statistics	4
MATH 250	Statistics 1	4

Select one of the following:

MATH 220	Discrete Mathematics	4
MATH 230	Linear Algebra	5

NATURAL SCIENCE (41-44 HOURS)

BIOL 151	Principles of Biology	5
CHEM 121	Introduction to General Chemistry 1	4
CHEM 122	Introduction to General Chemistry 2	4
GEOL 111	Rocks, Minerals, & Fossils	4
NTSC 110S	Scientific Reasoning & Methodology	4
PSCI 251	Physical Science by Inquiry 1	4
PSCI 252	Physical Science by Inquiry 2	4

Select three of the following:

BIOL 162	Human Anatomy & Physiology	5
BIOL 202	Principles of Plant Biology	5
BIOL 203	Principles of Animal Biology	5
BIOL 210	Taxonomy of Vascular Plants	4
BIOL 271	Field Ornithology	4
BIOL 272	Ohio's Natural Heritage	4
BIOL 302	Dendrology	4
BIOL 303	Spring Flora	4
BIOL 307	General Entomology	5
BIOL 370	Marine Biology	5
GEOL 112	Environmental Geology	4
GEOL 201	Physical Geology	4
GEOL 202	Historical Geology	4
GEOL 301	Invertebrate Paleobiology	4

Reading/Literature Requirement (18 Hours)

EDRE 302	Foundations of Literacy	5
EDRE 304	Teaching Phonics: Reading, Writing, & Spelling	5
EDRE 305	Teaching Reading in the Content Areas	4
ENGL 300	Children's Literature	4

Middle Childhood (Mathematics & Science) (36 Hours)

EDMC 285	Practicum & Seminar 1: Observation & Reflection in Professional Practice	4
EDMC 385	Pract. & Sem. 2: Action Research - Home, School, & Comm. Relations	4
EDMC 470	Instructional Strategies & Mgt.	4
EDMC 473	Teach. Math. in the Middle Grades	4
EDMC 476	Teach. Science in the Middle Grades	4
EDMC 485	Practicum & Seminar 3: Curriculum, Instruction, & Evaluation	4
EDMC 490	Directed Teaching & Seminar	12

Related Studies Component (16 Hours)

BUIS/ETCO	Computer Science Elective See page 81.	4
PSYC 101	Introduction to Psychology	4
PSYC 312	Adolescent Psychology	4
PSYC 375	Educational Psychology OR	4
PSYC 304	Psychology of Learning	4

Minor

Mathematical Sciences

If you decide not to major in mathematics, the mathematical sciences minor can accompany any baccalaureate degree offered by the University. The minor will strengthen your mathematical skills and improve your ability to solve problems in subject areas that use mathematics as a tool.

Requirements

A minor in the mathematical sciences consists of at least 29 credit hours in mathematics courses numbered 200 or above. Seventeen of these hours are required; you should consult with the chair of the Department of Mathematical Sciences regarding a study plan for the remaining hours.

Mathematical Sciences Minor Core (17 Hours)

The following courses are required of all students completing a minor in the mathematical sciences:

Course No.	Course	Cr. Hrs.
MATH 201	Calculus 1	4
MATH 202	Calculus 2	4
MATH 203	Calculus 3	4
MATH 230	Linear Algebra	5

Sample Course Sequence for Mathematical Sciences Minor

This is what a mathematics sequence might look like for a student whose major is in business.

MATH 201	Calculus 1	4
MATH 202	Calculus 2	4
MATH 203	Calculus 3	4
MATH 230	Linear Algebra	5
MATH 250	Statistics 1	4
MATH 350	Statistics 2	4
MATH 440	Mathematical Models	4

This is what a mathematics sequence might look like for a student whose major is in engineering technologies.

MATH 201	Calculus 1	4
MATH 202	Calculus 2	4
MATH 203	Calculus 3	4
MATH 220	Discrete Mathematics	4
MATH 230	Linear Algebra	5
MATH 301	Differential Equations	4
MATH 440	Mathematical Models	4

General Education Mathematics Requirements

In general, you may satisfy the mathematics component (Quantitative Reasoning - 4 hours, see page 56) of the General Education Program by completing one of the following courses:

- MATH 110S Mathematics Core Course (4)
- MATH 131 Precalculus 1 (4)
- MATH 150 Principles of Statistics (4)
- MATH 170 Applied Finite Mathematics (4)
- MATH 190 Brief Calculus with Applications (4)
- MATH 201 Calculus 1 (4)
- MATH 220 Discrete Mathematics (4)
- MATH 250 Statistics 1 (4)

However, some academic programs may require a specific MATH course to satisfy the General Education Program requirements. You should check with your faculty advisor before registering for a MATH course to see if it is one appropriate to your program and that you have fulfilled the course prerequisite.

Entrance into Mathematics Courses

If you are a degree-seeking student, you are required to use your ACT mathematics score or to take the COMPASS placement test in order to be admitted to a mathematics course. The following guidelines are used for mathematics placement.

- If you have a mathematics ACT score of 18 or below, you should take COMPASS for your mathematics placement.
- If you have a mathematics ACT score of 19-20, you do not need to take the placement test and may enter into MATH 110S, MATH 130, or MATH 150. Consult with your advisor about the appropriate course in your degree program.
- If you have a mathematics ACT score of 21-27, you do not need to take the placement test and may enter into MATH 131 or MATH 132. Contact the Department of Mathematical Sciences, 351.3301, for the appropriate course.
- If you have a Math ACT score of 28 or higher, you do not need to take the placement test and may enter into MATH 201.

Arrangements to take the COMPASS mathematics placement test are made with the Student Success Center, 351.3594.

Students who feel their placement test score is not indicative of their abilities in mathematics or feel they were placed into a course level too low should appeal their placement to the Department of Mathematical Sciences (351.3301) at the earliest possible date.

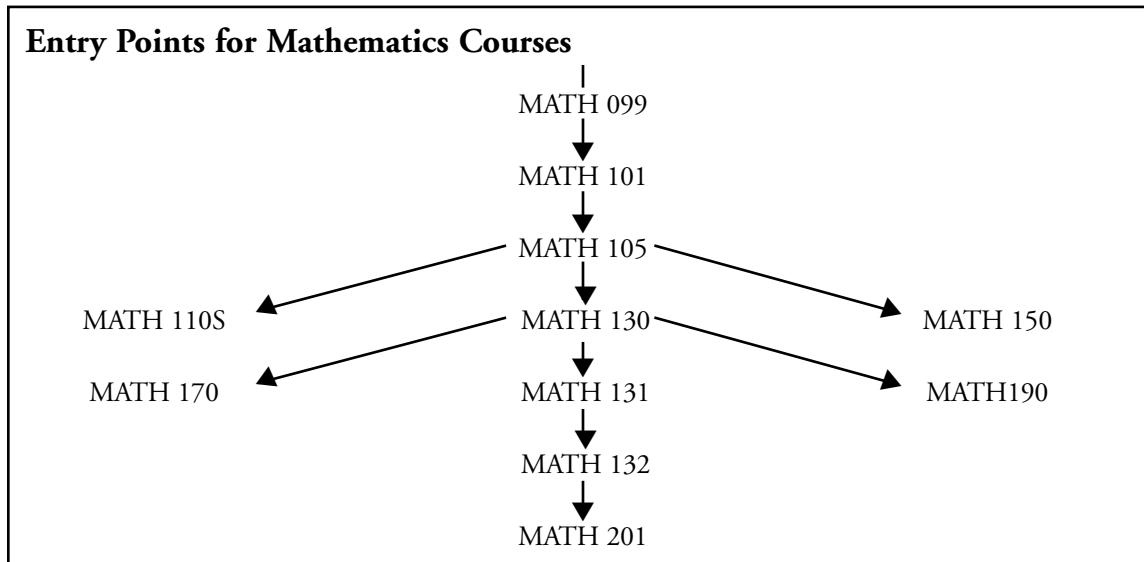



NATURAL SCIENCES



Natural Sciences

The Department of Natural Sciences prepares students for the challenges of the 21st century. This mission is accomplished:

- For science majors, through degree programs that provide depth and breadth in scientific learning, experience with modern technologies, and opportunities in undergraduate research and field studies.
- For students majoring in science-related disciplines, through service courses that provide science content and develop technical competence.
- For science majors and general education students, through courses that promote an understanding of scientific reasoning and methodology.

The Department of Natural Sciences offers modern instrumentation, including GC-MS, HPLC, AA, UV-Vis, FTIR, compound and dissecting microscopes for the life sciences, and polarizing microscopes for geological studies.

For the premedical studies student, the Department offers several advanced human anatomy electives rarely available at the undergraduate level. Instructional physics labs are equipped with Macintosh computers for collecting and processing data. The Department maintains, for the use of all natural sciences students, a lab containing ten computers and a laser printer.

In 1998, Shawnee State University was selected as a seismic station for the Division of Geological Survey of the Ohio Department of Natural Resources. The seismic station is housed in the Department of Natural Sciences.

For More Information

Gary Gemmer, M.A.T., Chairperson
Marilyn Mangus, B.S.J., Secretary

Department of Natural Sciences
Shawnee State University
940 Second Street
Portsmouth, Ohio 45662-4344

Phone: 740.351.3456

Fax: 740.351.3596

E-mail: mmangus@shawnee.edu or
science@shawnee.edu

Programs in Natural Science

Bachelor of Individualized Studies

See page 61 of current catalog for description.

Bachelor of Science

Biology

Chemistry

Natural Science

Natural Science

Earth Science with Adolescent to Young

Adult (Grades 7-12) Licensure

Integrated Science with Adolescent to Young

Adult (Grades 7-12) Licensure

Life Science with Adolescent to Young Adult

(Grades 7-12) Licensure

Mathematics and Science with Middle

Childhood (Grades 4-9) Licensure

Physical Science with Adolescent to Young

Adult (Grades 7-12) Licensure

Minors

Biology

Chemistry

Environmental Science

Associate of Science

See page 63 of current catalog for description.

Associate of Individualized Studies

See page 64 of current catalog for description.

Certificate in Environmental Science

Premedical Studies

Suggested course of study.

Waller Conservatory

The Waller Conservatory is a 1500 square foot, solarium-type greenhouse that is attached to the southeast corner of Massie Hall. It is part of the overall plant biology complex that also includes a support room for the Conservatory, large classroom/laboratory, conference room, and faculty office. The Conservatory was built almost entirely with donated funds; two large donations, one from the Kettering Foundation and the other from the local Waller family, were instrumental in making the facility possible.

Bachelor Degrees

■ **Special Note:** Students must complete—at Shawnee State—at least 16 credit hours in their majors. The 16 hours must be taken at the 300 or

400 level. In the case of the BS natural science, at least 12 of the 16 upper division hours must be in the first concentration.

Bachelor of Science in Biology

The bachelor of science in biology provides a broad intellectual foundation in the fundamentals of life science and is based on a philosophical commitment to relate modern life science to economic, environmental, and societal concerns. The curriculum insures a solid foundation in the biological sciences while offering the latitude to explore specific areas such as botany, zoology, ecology, systematics, and the biomedical sciences. BS biology recipients are prepared for careers in business, industry, and government or for advanced degree programs in biological or biomedical fields.

Degree Requirements

General Education Program (48 Hours) <i>The Quantitative Reasoning and Natural Science components of the GEP (4 and 8 hours, respectively) are satisfied by the requirements of the bachelor of science in biology. See page 55 for further information about the GEP.</i>	36 Hours
Biology Curriculum <i>(contains 35 hours of required courses) C- or better required in each course.</i>	65 Hours
Mathematics and Support Courses	46 Hours
General Electives	42 Hours
Minimum Hours Required	189 Hours

Biology Curriculum (65 Hours)

(Required courses listed, 35 hours)

Course No.	Course	Cr. Hrs.
BIOL 151	Principles of Biology	5
BIOL 202	Principles of Plant Biology	5
BIOL 203	Principles of Animal Biology	5
BIOL 330	Ecology	5
BIOL 340	Genetics	5
BIOL 432	Cell Biology	5
BIOL 440	Molecular Biology	5

BIOLOGY ELECTIVES (30 HOURS)

A minimum of 20 hours numbered 300 or above and 4 hours numbered 400 or above. A maximum of six credit hours of BIOL 495 may be used for biology electives. Consult your faculty advisor when choosing biology electives.

Mathematics and Support Courses (46 Hours)

MATH 131	College Algebra	4
MATH 132	Precalculus 2	4
MATH 150	Principles of Statistics OR	4
MATH 250	Statistics 1	
CHEM 141	General Chemistry 1	5

CHEM 142	General Chemistry 2	5
CHEM 143	General Chemistry 3	5
CHEM 200	Intro. to Organic Chemistry OR	4
CHEM 305	Organic Chemistry 1	
NTSC 110S	Scientific Reasoning & Methodology	4
PHYS - - -	Physics Elective (<i>PHYS 210 cannot be used for physics elective</i>)	4
	Computer Science Elective	4
SPCH 103	Public Speaking & Human Comm.	3

General Electives (42 Hours)

Elective hours are not limited to any particular area of study and can be earned in science to enhance the major or to complete requirements for a minor. Courses from all departments of the University can be used to satisfy the electives requirements. Electives should include courses in the arts and humanities. Coherent groups of courses are encouraged and should be chosen with the student's career objectives and personal interests in mind. Consultation with your faculty advisor is highly recommended so that electives can be an important component of your educational experience.

Bachelor of Science in Chemistry

The bachelor of science in chemistry is designed for students who wish to pursue a professional career in industry or government, a medical degree, or graduate studies in chemistry and allied disciplines. Frequent consultation with your faculty advisor is strongly encouraged.

Degree Requirements

General Education Program (48 Hours) <i>The Quantitative Reasoning and Natural Science components of the GEP (4 and 8 hours, respectively) are satisfied by the requirements of the bachelor of science in chemistry. See page 55 for further information about the GEP.</i>	36 Hours
Chemistry Curriculum	61 Hours
Mathematics and Support Courses	39 Hours
General Electives	50 Hours
Minimum Hours Required	186 Hours

Chemistry Curriculum (61 Hours)

Course No.	Course	Cr. Hrs.
CHEM 141	General Chemistry 1	5
CHEM 142	General Chemistry 2	5
CHEM 143	General Chemistry 3	5
CHEM 305	Organic Chemistry 1	4
CHEM 306	Organic Chemistry 2	4
CHEM 307	Organic Chemistry 3	4
CHEM 323	Analytical Chemistry 1	5
CHEM 325	Analytical Chemistry 2	5
CHEM 431	Physical Chemistry 1	4

CHEM 432	Physical Chemistry 2	4
CHEM 433	Physical Chemistry 3	4
CHEM 441	Inorganic Chemistry	4
CHEM 495	Undergraduate Research	4
BIOL 411	Biochemistry	4

Mathematics and Support Courses (39 Hours)

MATH 201	Calculus 1	4
MATH 202	Calculus 2	4
MATH 203	Calculus 3	4
MATH 204	Calculus 4	4
MATH 250	Statistics 1	4
NTSC 110S	Scientific Reasoning & Methodology	4
SPCH 103	Public Speaking & Human Comm.	3

either:

PHYS 211	Calculus-Based Physics 1	4
PHYS 212	Calculus-Based Physics 2	4
PHYS 213	Calculus-Based Physics 3	4

or:

PHYS 201	Physics 1 (Mechanics)	4
PHYS 202	Physics 2 (Electricity & Magnetism)	4
PHYS 203	Physics 3 (Energy)	4

General Electives (50 Hours)

Elective hours are not limited to any particular area of study and can be earned in science to enhance the major or to complete requirements for a minor. Courses from all departments of the University can be used to satisfy the electives requirements. Electives should include courses in the arts and humanities. Coherent groups of courses are encouraged and should be chosen with the student's career objectives and personal interests in mind. Consultation with your faculty advisor is highly recommended so that electives can be an important component of your educational experience.

Bachelor of Science in Natural Science

The bachelor of science in natural science is offered with or without education licensure.

Bachelor of Science in Natural Science (without licensure)

The BSNS (without licensure) serves students who seek education and a career in science or a science-related field. BSNS students must complete coursework in an area of concentration (chemistry or biology) and at least two other areas of math or science. Recent recipients of the BSNS are employed as health professionals, laboratory technicians, environmental consultants, naturalists, and in other positions in business, industry, and

government. Students pursuing the BSNS should meet with a faculty advisor to design their program.

The Department of Natural Sciences is currently developing a BSNS with a concentration in geology. Pending final approval, the geology concentration will be available for students seeking careers in earth science, environmental science, or entry into graduate programs in geology or environmental science. For information concerning this degree program and its status, contact Dr. Jeffrey Bauer or the Department of Natural Sciences.

Degree Requirements

General Education Program ^(48 Hours) 40 Hours

The Natural Science component of the GEP (8 hours) is satisfied by the requirements of the bachelor of science in natural science. See page 55 for further information about the GEP.

Concentration: Biology (BIOL) 40 Hours
or Chemistry (CHEM)

A minimum of 40 hours of courses in biology or chemistry. Courses must be numbered higher than 110. The 40 hours must include a minimum of 16 hours at the 300 or 400 level, with at least 4 of those hours at the 400 level. Required courses for biology concentration are BIOL 151, 202, 203. A maximum of 6 hours of BIOL 495 may be applied to the biology concentration. Required courses for the chemistry concentration are CHEM 141, 142, 143, 305, 306, 307, 323, 325, and one of the following: BIOL 411, CHEM 431, or CHEM 441.

Additional Science/Math. Require. 36 Hours

In addition to the 40 hours of courses in the concentration area, students are required to take at least 36 additional hours of science and mathematics courses. These courses may be any combination of biology, chemistry, geology, physics, and mathematics courses, as long as the combination includes at least 12 hours from each of two math/science areas other than the concentration. Physics 201, 202, 203 (or 211, 212, 213) are recommended for students pursuing a chemistry concentration. Mathematics courses used for this requirement must be numbered 132 or above.

NTSC 110S Sci. Reason. & Meth. 4 Hours

SPCH 103 Public Speaking 3 Hours

Mathematics Proficiency Requirement

Each student must show proficiency in MATH 131 or MATH 170 or MATH 190 through course completion or placement.

Electives 63 Hours

Elective hours are not limited to any particular area of study and can be earned in science to enhance the major or to complete requirements for a minor. Courses from all departments of the University can be used to satisfy the electives requirements. Electives should include courses in the arts and humanities. Coherent groups of courses are encouraged and should be chosen with the student's career objectives and personal

interests in mind. Consultation with your faculty advisor is highly recommended so that electives can be an important component of your educational experience.

Bachelor of Science in Natural Science (with licensure)

For the natural sciences major interested in a career in education, the Department of Natural Sciences, in conjunction with the Department of Teacher Education, offers five baccalaureates in natural science accompanied by licensure. Students seeking a BSNS with licensure are assigned a faculty advisor in both departments.

Students pursuing the middle childhood license to teach mathematics and science may select from one of two degrees. In addition to this bachelor of science in natural science, a bachelor of science in education is available. See pages 112 and 113 of this catalog. Consult an advisor in science, mathematics, or education to discuss which option best meets your needs.

Degree Requirements for Bachelor of Science in Natural Science; Earth, Life, or Physical Science with Adolescent to Young Adult (Grades 7-12) Licensure

General Education Program (48 Hours) 36 Hours
The Quantitative Reasoning and Natural Science components of the GEP are satisfied by the requirements of the bachelor of science in natural science. IDST 225S or 226S is required. Further information is listed on page 55 of the current catalog or can be obtained from the Department of Teacher Education.

Science Component 83-93 Hours
 Professional Education Core 20 Hours
 Reading/Literature Require. 8 Hours
 Related Studies Component 16 Hours
 Adolescent/Young Adult Courses 32 Hours

Total Hours Required:

Earth Science 197 Hours
Life Science 195-196 Hours
Physical Science 205 Hours

Science Component (83-93 Hours)

Choose one science component from among the following:

EARTH SCIENCE (85 HOURS)

Course No.	Course	Cr. Hrs.
BIOL 151	Principles of Biology	5
BIOL 370	Marine Biology	5

CHEM 141	General Chemistry 1	5
CHEM 142	General Chemistry 2	5
CHEM 143	General Chemistry 3	5
GEOL 111	Rocks, Minerals, & Fossils	4
GEOL 112	Environmental Geology	4
GEOL 201	Physical Geology	4
GEOL 202	Historical Geology	4
GEOL 301	Invertebrate Paleobiology OR	4
GEOL 303	Sedimentary Rocks	
GEOL 302	Mineralogy	4
GEOL 401	Field Methods	4
GEOL 485	Senior Project	4
MATH 131	Precalculus 1 <i>or higher</i>	4
MATH 150	Principles of Statistics OR	4
MATH 250	Statistics 1	
MATH 190	Brief Calculus with Applications	4
NTSC 110S	Scientific Reasoning & Methodology	4
GEOG 311	Air Pollution OR	4
GEOG 227	Foundations of Meteorology	
PHYS 210	Astronomy	4
PSCI 251	Physical Science by Inquiry 1	4

LIFE SCIENCES (83-84 HOURS)

BIOL 151	Principles of Biology	5
BIOL 162	Human Anatomy & Physiology OR	5
BIOL 320	Principles of Physiology OR	
BIOL 470	Plant Physiology	
BIOL 202	Principles of Plant Biology	5
BIOL 203	Principles of Animal Biology	5
BIOL 330	Ecology	5
BIOL 340	Genetics	5
BIOL 350	Microbiology	5
BIOL 432	Cell Biology	5
BIOL 485	Senior Project	4
BIOL XXX	Biology Elective	4-5
CHEM 141	General Chemistry 1	5
CHEM 142	General Chemistry 2	5
CHEM 143	General Chemistry 3	5
GEOL 111	Rocks, Minerals, & Fossils	4
MATH 131	College Algebra <i>or higher</i>	4
MATH 150	Principles of Statistics OR	4
MATH 250	Statistics 1	
NTSC 110S	Scientific Reasoning & Methodology	4
PSCI 251	Physical Science by Inquiry 1	4

PHYSICAL SCIENCE (93 HOURS)

BIOL 151	Principles of Biology	5
CHEM 141	General Chemistry 1	5
CHEM 142	General Chemistry 2	5
CHEM 143	General Chemistry 3	5
CHEM 305	Organic Chemistry 1	4
CHEM 306	Organic Chemistry 2	4
CHEM 307	Organic Chemistry 3	4
CHEM 323	Quantitative Analysis	5
CHEM 485	Senior Project OR	4
PHYS 485	Senior Project	
GEOL 111	Rocks, Minerals, & Fossils	4
MATH 201	Calculus 1	4
MATH 202	Calculus 2	4
MATH 250	Statistics 1	4
NTSC 110S	Scientific Reasoning & Methodology	4
PHYS 210	Astronomy	4
PHYS 211	Calculus-Based Physics 1	4
PHYS 212	Calculus-Based Physics 2	4
PHYS 213	Calculus-Based Physics 3	4

PHYS 214	Calculus-Based Physics 4	4
PHYS 300	Modern Physics	4
PSCI 251	Physical Science by Inquiry 1	4
PSCI 252	Physical Science by Inquiry 2	4

Professional Education Core (20 Hours)

EDUC 115	Intro. to the Teaching Profession	4
EDUC 230	Instructional Media, Technology, & Computers	4
EDUC 240	School & Society: Legal, Theoretical Philosophical, & Ethical Found. of American Education	4
EDUC 245	Teaching Individuals in a Pluralistic Society	4
EDUC 310	Strategies of Assess., Diagnosis, & Evaluation in the Classroom	4

Reading/Literature Requirement (8 Hours)

EDRE 305	Teaching Reading in the Content Areas	4
ENGL 323	Adolescent Literature	4

Related Studies Component (16 Hours)

BUIS/ETCO	Computer Science Elective See page 81.	4
PSYC 101	Introduction to Psychology	4
PSYC 304	Psychology of Learning OR	4
PSYC 375	Educational Psychology	4
PSYC 312	Adolescent Psychology	4

Adolescent/Young Adult Courses (32 Hours)

EDAE 285	Practicum & Seminar 1: Observation & Reflection in Professional Practice	4
EDAE 385	Pract. & Sem. 2: Action Research - Home, School, & Comm. Relations	4
EDAE 400	Prin. & Strategies of Curriculum Develop., Mgt., & Instruction	4
EDAE 485	Practicum & Seminar 3: Curriculum, Instruction, & Evaluation	4
EDAE 490	Directed Teaching & Seminar	12
NTSC 433	Teaching Science in Grades 7-12	4

Degree Requirements for Bachelor of Science in Natural Science, Integrated Science with Adolescent to Young Adult (Grades 7-12) Licensure

This program combines extensive work in a number of science areas with a license to teach all science areas in grades 7-12. Because of this, completion may take longer than a standard degree or program.

Degree Requirements

General Education Program (48 Hours)	36 Hours
<i>The Quantitative Reasoning and Natural Science components of the GEP are satisfied by the requirements of the bachelor of science in natural science. IDST 225S or 226S, PHIL 320S, and SOSC</i>	

110S are required. Further information is listed on page 55 of the current catalog or can be obtained from the Department of Teacher Education.

Integrated Science Component	122-126 Hours
Professional Education Core	20 Hours
<i>See left column this page.</i>	
Reading/Literature Requirement	8 Hours
<i>See left column this page.</i>	
Related Studies Component	12 Hours
Adolescent/Young Adult Courses	32 Hours
Total Hours Required	230-234 Hours

Integrated Science Component (122-126 Hours)

Course No.	Course	Cr. Hrs.
MATH 201	Calculus 1	4
MATH 202	Calculus 2	4
MATH 250	Statistics 1	4

Select one principal area of study from the following:

BIOLOGY (39 HOURS)

BIOL 151	Principles of Biology	5
BIOL 162	Human Anatomy & Physiology OR	5
BIOL 320	Principles of Physiology OR	
BIOL 470	Plant Physiology	
BIOL 202	Principles of Plant Biology OR	5
BIOL 203	Principles of Animal Biology	
BIOL 330	Ecology	5
BIOL 340	Genetics	5
BIOL 350	Microbiology	5
BIOL 432	Cell Biology	5
NTSC 110S	Scientific Reasoning & Methodology	4

CHEMISTRY (40 HOURS)

CHEM 141	General Chemistry 1	5
CHEM 142	General Chemistry 2	5
CHEM 143	General Chemistry 3	5
CHEM 305	Organic Chemistry 1	4
CHEM 306	Organic Chemistry 2	4
CHEM 307	Organic Chemistry 3	4
CHEM 323	Quantitative Analysis	5
BIOL 411	Biochemistry	4
NTSC 110S	Scientific Reasoning & Methodology	4

EARTH AND SPACE (37 HOURS)

BIOL 370	Marine Biology	5
GEOL 111	Rocks, Minerals, & Fossils	4
GEOL 112	Environmental Geology	4
GEOL 201	Physical Geology	4
GEOL 202	Historical Geology	4
GEOL XXX	Geology Elective	4
GEOG 227	Foundations of Meteorology	4
NTSC 110S	Scientific Reasoning & Methodology	4
PHYS 210	Astronomy	4

PHYSICS (36 HOURS)

NTSC 110S	Scientific Reasoning & Methodology	4
PHYS 210	Astronomy	4
PHYS 211	Calculus-Based Physics 1	4
PHYS 212	Calculus-Based Physics 2	4
PHYS 213	Calculus-Based Physics 3	4
PHYS 214	Calculus-Based Physics 4	4

Course No.	Course	Cr. Hrs.
PHYS 300	Modern Physics	4
PSCI 251	Physical Science by Inquiry 1	4
PSCI 252	Physical Science by Inquiry 2	4

Integrated science students must complete the three areas below not chosen as their principal area of study. Students may not duplicate their principal and subordinate areas of study. (Example: Students who choose biology as their principal area of study must take chemistry, earth and space, and physics as their subordinate areas of study.)

BIOLOGY AS SUBORDINATE AREA (25 HOURS)

BIOL 151	Principles of Biology	5
BIOL 162	Human Anatomy & Physiology OR	5
BIOL 320	Principles of Physiology OR	
BIOL 470	Plant Physiology	
BIOL 202	Principles of Plant Biology	5
BIOL 203	Principles of Animal Biology	5
BIOL 350	Microbiology	5

CHEMISTRY AS SUBORDINATE AREA (24 HOURS)

CHEM 141	General Chemistry 1	5
CHEM 142	General Chemistry 2	5
CHEM 143	General Chemistry 3	5
CHEM 200	Introduction to Organic Chemistry	4
CHEM 323	Quantitative Analysis	5

EARTH AND SPACE AS SUBORDINATE AREA (25 HOURS)

BIOL 370	Marine Biology	5
GEOL 111	Rocks, Minerals, & Fossils	4
GEOL 112	Environmental Geology	4
GEOL XXX	Geology Elective	4
GEOG 227	Foundations of Meteorology	4
PHYS 210	Astronomy	4

PHYSICS AS SUBORDINATE AREA (24 HOURS)

PHYS 211	Calculus-Based Physics 1	4
PHYS 212	Calculus-Based Physics 2	4
PHYS 213	Calculus-Based Physics 3	4
PHYS 214	Calculus-Based Physics 4	4
PHYS 300	Modern Physics	4
PSCI 251	Physical Science by Inquiry 1	4

Related Studies Component (12 Hours)

PSYC 101	Introduction to Psychology	4
PSYC 304	Psychology of Learning OR	4
PSYC 375	Educational Psychology	
PSYC 312	Adolescent Psychology	4

Adolescent/Young Adult Courses (32 Hours)

EDAE 285	Practicum & Seminar 1: Observation & Reflection in Professional Practice	4
EDAE 385	Pract. & Sem. 2: Action Research - Home, School, & Comm. Relations	4
EDAE 400	Prin. & Strategies of Curriculum Develop., Mgt., & Instruction	4
EDAE 485	Practicum & Seminar 3: Curriculum, Instruction, & Evaluation	4
EDAE 490	Directed Teaching & Seminar	12
NTSC 433	Teaching Science in Grades 7-12	4

Degree Requirements for Bachelor of Science in Natural Science, Mathematics and Science with Middle Childhood (Grades 4-9) Licensure

General Education Program (48 Hours) 36 Hours

The Quantitative Reasoning and Natural Science components of the GEP (4 and 8 hours, respectively) are satisfied by the requirements of the bachelor of science in natural science. See page 55 for further information about the GEP.

Content Component 85-89 Hours

Professional Education Core 20 Hours

See page 91 of the current catalog.

Reading/Literature Requirement 18 Hours

Middle Childhood (Math. & Science) 36 Hours

Related Studies Component 16 Hours

Minimum Hours Required 211-215 Hours

Content Component (85-89 Hours)

MATHEMATICS (44-45 HOURS)

Course No.	Course	Cr. Hrs.
MATH 110S	Mathematics Core Course	4
MATH 140	Elementary Topics in Math. 1	4
MATH 141	Elementary Topics in Math. 2	4
MATH 300	History of Mathematics	4
MATH 305	Math. Enrichment for the Teacher	4
MATH 320	Foundations of Geometry	4
MATH 496	Senior Research Project 1	1
MATH 497	Senior Research Project 2	2
MATH 498	Senior Research Project 3	1

Select one pair of the following courses:

MATH 132	Precalculus 2	4
MATH 190	Brief Calculus with Applications	4

or

MATH 201	Calculus 1	4
MATH 202	Calculus 2	4

Select one of the following:

MATH 150	Principles of Statistics	4
MATH 250	Statistics 1	4

Select one of the following:

MATH 220	Discrete Mathematics	4
MATH 230	Linear Algebra	5

NATURAL SCIENCE (41-44 HOURS)

BIOL 151	Principles of Biology	5
CHEM 121	Introduction to General Chemistry 1	4
CHEM 122	Introduction to General Chemistry 2	4
GEOL 111	Rocks, Minerals, & Fossils	4
NTSC 110S	Scientific Reasoning & Methodology	4
PSCI 251	Physical Science by Inquiry 1	4
PSCI 252	Physical Science by Inquiry 2	4

Select three of the following:

BIOL 162	Human Anatomy & Physiology	5
BIOL 202	Principles of Plant Biology	5
BIOL 203	Principles of Animal Biology	5
BIOL 210	Taxonomy of Vascular Plants	4

BIOL 271	Field Ornithology	4
BIOL 272	Ohio's Natural Heritage	4
BIOL 302	Dendrology	4
BIOL 303	Spring Flora	4
BIOL 307	General Entomology	5
BIOL 370	Marine Biology	5
GEOL 112	Environmental Geology	4
GEOL 201	Physical Geology	4
GEOL 202	Historical Geology	4
GEOL 301	Invertebrate Paleobiology	4

Reading/Literature Requirement (13 Hours)

EDRE 302	Foundations of Literacy	5
EDRE 304	Teaching Phonics: Reading, Writing, & Spelling	5
EDRE 305	Teaching Reading in the Content Areas	4
ENGL 300	Children's Literature	4

Middle Childhood Component (36 Hours)

EDMC 285	Practicum & Seminar 1: Observation & Reflection in Professional Practice	4
EDMC 385	Pract. & Sem. 2: Action Research - Home, School, & Comm. Relations	4
EDMC 470	Instructional Strategies & Mgt.	4
EDMC 473	Teach. Math. in the Middle Grades	4
EDMC 476	Teach. Science in the Middle Grades	4
EDMC 485	Practicum & Seminar 3: Curriculum, Instruction, & Evaluation	4
EDMC 490	Directed Teaching & Seminar	12

Related Studies Component (16 Hours)

BUIS/ETCO	Computer Sci. Elective See page 81.	4
PSYC 101	Introduction to Psychology	4
PSYC 312	Adolescent Psychology	4
PSYC 375	Educational Psychology OR	4
PSYC 304	Psychology of Learning	4

Certificate in Environmental Science

A certificate in environmental science may accompany a baccalaureate in chemistry, biology, or natural science. Advisors in the environmental science certificate program should be consulted concerning internships as well as employment opportunities within the environmental area.

Required Courses (71 Hours)

Any deviations from the curriculum must be approved in advance by the chairperson of the Department of Natural Sciences.

Course No.	Course	Cr. Hrs.
BIOL 151	Principles of Biology	5
BIOL 202	Principles of Plant Biology	5
BIOL 330	Ecology	5
CHEM 141	General Chemistry 1	5

CHEM 142	General Chemistry 2	5
CHEM 143	General Chemistry 3	5
CHEM 323	Analytical Chemistry 1	5
GEOG 311	Geography of Air Pollution	4
GEOL 112	Environmental Geology	4
GEOL 201	Physical Geology	4
MATH 201	Calculus 1	4
MATH 250	Statistics 1	4
NTSC 240	Intro. to Environmental Science	4
PHYS 201	Physics 1 (Mechanics)	4
PHYS 203	Physics 3 (Energy)	4

Choose one of the senior project or research courses below.

Note: Project or research must be environmentally related.

BIOL 485, BIOL 495, CHEM 485, CHEM 495, GEOL 485, GEOL 495	4
--	---

Minors

Biology

The biology minor may accompany any baccalaureate offered by the University. Program requirements are as follows:

Course No.	Course	Cr. Hrs.
BIOL 151	Principles of Biology	5
BIOL 202	Principles of Plant Biology	5
BIOL 203	Principles of Animal Biology	5

Select one of the following:

BIOL 330	Ecology	5
BIOL 340	Genetics	5
BIOL 432	Cell Biology	5
BIOL - - -	Biology Electives (<i>At least one course numbered 300 or above.</i>)	10

Chemistry

The chemistry minor may accompany any baccalaureate offered by the University. Program requirements are as follows:

Course No.	Course	Cr. Hrs.
CHEM 141	General Chemistry 1 (<i>or CHEM 121 and 122</i>)	5
CHEM 142	General Chemistry 2	5
CHEM 143	General Chemistry 3	5
CHEM XXX	Chemistry Electives (<i>At or above the 300 level. BIOL 411, Biochemistry, may be counted as a chemistry elective.</i>)	16

Environmental Science

The environmental science minor is designed to accompany baccalaureates other than biology, chemistry, and natural science. Students seeking a B.S. biology, B.S. chemistry, or B.S. natural science and interested in an environmental focus should acquire the certificate in environmental science.

Required Courses

Course No.	Course	Cr. Hrs.
BIOL XXX	Biology Elective	4
CHEM 121	Intro. to General Chemistry 1 OR	4/5
CHEM 141	General Chemistry 1	
GEOL 112	Environmental Geology	4
NTSC 240	Intro. to Environmental Science	4

Select one of the following:

BIOL 151	Principles of Biology	5
CHEM 143	General Chemistry 3	5
GEOL 201	Physical Geology	4

Electives

Two additional courses from the following list:

BIOL 202 Principles of Plant Biology, BIOL 203 Principles of Animal Biology, BIOL 210 Taxonomy of Vascular Plants, BIOL 271 Field Ornithology, BIOL 272 Ohio's Natural Heritage, BIOL 302 Dendrology, BIOL 303 Spring Flora, BIOL 307 General Entomology, BIOL 330 Ecology, BIOL 331 Advanced Field Biology, BIOL 350 Microbiology, BIOL 365 Phycology, BIOL 370 Marine Biology, CHEM 122 Introduction to General Chemistry 2, CHEM 142 General Chemistry 2, CHEM 200 Introduction to Organic Chemistry, GEOG 311 Geography of Air Pollution, GEOL 201 Physical Geology, GEOL 202 Historical Geology, GOVT 401 State of the World

Premedical Studies

Admission requirements for every accredited medical school in the United States can be found in *Medical School Admission Requirements*, published by the Association of American Medical Colleges and available in the Shawnee State library. While there is general commonality in minimum requirements, **the premedical studies student should consult the professional school of interest for exact admission requirements.**

The following are the minimal requirements recommended by graduate programs in clinical medical science (including optometry, dentistry, veterinary medicine, MD and DO programs) in the state of Ohio:

- 1 year general biology
- 1 year anatomy and physiology
- 1 year general chemistry
- 1 year organic chemistry
- 1 year physics
- Proficiency at MATH 132 level (some schools require Calculus 1)

Suggested Sequence of Courses for Premedical Studies

The following are premedical course sequences for biology and chemistry majors. In addition to the courses listed below, students must complete minimum requirements for the BS in biology or the BS in chemistry given on previous pages.

For Biology Majors:

FIRST YEAR

Course No.	Course	Cr. Hrs.
BIOL 151	Principles of Biology	5
BIOL 202	Principles of Plant Biology	5
BIOL 203	Principles of Animal Biology	5
CHEM 141	General Chemistry 1	5
CHEM 142	General Chemistry 2	5
CHEM 143	General Chemistry 3	5
Math	<i>Proficiency at Math 132 level</i>	

SECOND YEAR

BIOL 310	Principles of Anatomy	5
BIOL 320	Principles of Physiology	5
BIOL 350	Microbiology	5
PHYS 201	Physics 1	4
PHYS 202	Physics 2	4
PHYS 203	Physics 3	4
MATH 150	Principles of Statistics	4

THIRD YEAR

BIOL 314	Human Neuroanatomy OR	5
BIOL 410	Advanced Human Anatomy	
BIOL 315	Histology OR	5
BIOL 450	Immunology	
BIOL 330	Ecology	5
CHEM 305	Organic Chemistry 1	4
CHEM 306	Organic Chemistry 2	4
CHEM 307	Organic Chemistry 3	4

FOURTH YEAR

BIOL 314	Human Neuroanatomy OR	5
BIOL 410	Advanced Human Anatomy	
BIOL 315	Histology OR	5
BIOL 450	Immunology	
BIOL 340	Genetics	5
BIOL 407	Pathogenic Bacteriology	5
BIOL 411	Biochemistry	4
BIOL 432	Cell Biology	5

For Chemistry Majors:

FIRST YEAR

Course No.	Course	Cr. Hrs.
BIOL 151	Principles of Biology	5
BIOL 202	Principles of Plant Biology	5
BIOL 203	Principles of Animal Biology	5
CHEM 141	General Chemistry 1	5
CHEM 142	General Chemistry 2	5
CHEM 143	General Chemistry 3	5
Math	<i>Proficiency at Math 132 level</i>	

SECOND YEAR

BIOL 310	Principles of Anatomy	5
BIOL 320	Principles of Physiology	5
BIOL 350	Microbiology	5
CHEM 305	Organic Chemistry 1	4
CHEM 306	Organic Chemistry 2	4
CHEM 307	Organic Chemistry 3	4
PHYS 201	Physics 1	4
PHYS 202	Physics 2	4
PHYS 203	Physics 3	4

THIRD YEAR

BIOL 411	Biochemistry	4
<i>Choose either sequence below:</i>		
CHEM 323	Analytical Chemistry 1	5
CHEM 325	Analytical Chemistry 2	5
<i>or</i>		
CHEM 431	Physical Chemistry 1	4
CHEM 432	Physical Chemistry 2	4
CHEM 433	Physical Chemistry 3	4

FOURTH YEAR

CHEM 441	Inorganic Chemistry	4
CHEM 495	Undergraduate Research	1-4
<i>Choose either sequence below:</i>		
CHEM 323	Analytical Chemistry 1	5
CHEM 325	Analytical Chemistry 2	5
<i>or</i>		
CHEM 431	Physical Chemistry 1	4
CHEM 432	Physical Chemistry 2	4
CHEM 433	Physical Chemistry 3	4

In addition to the courses listed above, students will benefit from completing Sectional Anatomy, Undergraduate Research, Pathogenic Microbiology, Virology, and Neuroanatomy.

Grade point average, performance on the Medical College Admissions Test (MCAT), an interview and undergraduate academic recommendations are some of the more important factors considered by medical school admission committees.



SOCIAL SCIENCES



Social Sciences

The Department of Social Sciences provides general education students a sense of the importance of cultural influences, a sense of history within the scope of changing cultural themes, and a sense of their own worth as human beings. These understandings are refined through a sound curriculum in the behavioral sciences, which explains variations in human behavior based on theoretical models, instruction in research methods used by contemporary social scientists, and a special focus on interdisciplinary connections among topical social issues.

For More Information

James M. Miller, Ph.D., Chairperson
 Department of Social Sciences
 Shawnee State University
 940 Second Street
 Portsmouth, Ohio 45662-4344
 Phone: 740.351.3234
 Fax: 740.351.3153
 E-mail: jmillers@shawnee.edu

Programs in Social Science

Bachelor of Arts

History
 International Relations
 Psychology
 Social Sciences
 Social Sciences, Legal Assisting (2+2)
 Social Sciences, Adolescent to Young Adult
 (Grades 7-12) Licensure, Integrated Social
 Studies
 Sociology

Bachelor of Individualized Studies

See page 61 of current catalog for description.

Minors

Economics
 Geography
 History
 Political Science
 Psychology
 Sociology

Associate of Arts

Social Science
 See page 62 of current catalog for description.

Associate of Individualized Studies

See page 64 of current catalog for description.

Bachelor Degrees

Bachelor of Arts with a Major in History

The Department of Social Sciences' history program provides students with a general understanding of the development of American, western, and select non-western civilizations. Special attention is given to 20th century history, the problems of modernization, and the increasing connections between societies. In developing these understandings, you learn to draw upon the insights and techniques of cognate social science disciplines.

The program encourages you to develop your analytical capacities, research skills, and writing talents, which, in turn, stand you in good stead as you pursue a career in law, education, journalism, government service, or the private sector.

Some of the courses you choose to meet the requirement for the history major may also count as General Education courses. See your advisor for further information.

Degree Requirements

General Education Program	48 Hours
<i>Further information is listed on page 55 of the current catalog or can be obtained from the dean's office.</i>	
History Survey Courses	24 Hours
History Upper-Division Courses (300-400 Level)	24 Hours
Social Science Upper-Division Cognate Courses (from following list)	12 Hours
Elective Courses	78 Hours
Total Hours Required	186 hours

History Survey Courses (24 Hours)

The following courses must be completed with a minimum grade of C.

HIST 111, 112, and 113 (American Survey)	12 Hrs.
HIST 201, 202, and 203 (European Survey)	12 Hrs.

History Upper-Division Courses (24 Hours)

A minimum grade of C must be achieved in any course used to fulfill this degree requirement.

TWO U.S. HISTORY COURSES FROM:

Course No.	Course	Cr. Hrs.
ECON 326	Economic History of the U.S.	4
HIST 301	Form. of the Am. Nation, 1750-1815	4
HIST 303	American Civil War	4
HIST 305	From FDR to Reagan	4
HIST 320	Hist. of Amer. Foreign Relations	4

TWO UPPER-DIVISION EUROPEAN COURSES FROM:

HIST 310	Nazi Germany	4
HIST 325	History of Russia	4
HIST 401	History of Medicine	4
HIST 410	Intellectual History 1	4
HIST 411	Intellectual History 2	4

TWO UPPER-DIVISION NON-WESTERN COURSES FROM:

ANTH 340	MesoAmerica Before Columbus	4
HIST 330	History of South Africa	4
HIST 360	East Asian History	4
HIST 371	Islamic Culture & Civilization	4
HIST 420	Middle East in Modern Times	4

Social Science Upper-Division Cognate Courses (12 Hours)

A minimum grade of C must be achieved in any course used to fulfill this degree requirement.

ANTH 360	Indians of North America	4
ECON 405	Economic Development	4
ECON 411	Comparative Economic Systems	4
GEOG 310	Medical Geography	4
GEOG 350	Geography of North America	4
GEOG 351	Regional Geog. of the Middle East	4
GOVT 310	American Foreign Policy	4
GOVT 320	Third World Politics	4
GOVT 330	Mass Media Politics	4
GOVT 340	European Politics	4
GOVT 350	National Public Policy	4
GOVT 401	State of the World	4
GOVT 420	International Political Economy	4
SOCI 312	Sociology of Religion	4
SOCI 330	Social Theory	4
SOCI 340	Sociology of Appalachia	4
SOCI 370	Alternative Religions & Cults	4
SOCI 380	Sociological Methods	4

Elective Courses (78 Hours)

You are free to select courses from any of the University's offerings that you find useful. Faculty advisors are happy to offer suggestions on what areas of study might be particularly beneficial to you.

Special Notes

- Students must achieve a grade of C or higher in every course in the history major.
- The chairperson must approve any variation from the required program.

Bachelor of Arts with a Major in International Relations

The international relations degree examines the nature of the global economy, communications, politics, and cultures; the consequences of the increasing environmental interdependence among regions of the world; and the unfolding of a variety of other crossborder issues. The program aims to provide its graduates with the conceptual and substantive tools necessary to function more advantageously and effectively in a "shrinking" world; the global village concept. The degree consists of courses from many academic disciplines such as government, economics, business, history, and sociology, and contains a foreign language requirement.

Some of the courses you choose to meet the requirement for the international relations major may also count as General Education courses. See your advisor for further information.

Careers

Graduates can opt for careers in local, state, national, and international government institutions or in trade and commerce chambers or in professional associations or other nongovernmental agencies such as contracting and consulting firms, nonprofit organizations, foundations and research establishments, and political support and interest groups. Careers are also possible in the growing national and international tourist industry or in international business and finance, print and broadcast media, public relations, and advertising firms. Graduates can also pursue a variety of related graduate studies (i.e., international relations, political science, law).

Degree Requirements

General Education Program	48 Hours
<i>Further information is listed on page 55 of the current catalog or can be obtained from the dean's office.</i>	
International Relations Courses	24 Hours
Cognate Concentrations	36 Hours

Foreign Language	12 Hours
University Electives	70 Hours
Total Hours Required	190 hours

International Relations Courses (24 Hours)

Course No.	Course	Cr. Hrs.
ECON 405	Economic Development	4
GOVT 310	United States Foreign Policy OR	4
HIST 320	History of Am. Foreign Relations	
GOVT 320	Third World Politics	4
GOVT 370	Global Politics	4
GOVT 401	State of the World	4
GOVT 420	International Political Economy	4

Cognate Concentrations (36 Hours)

POLITICAL SCIENCE

GOVT 250	Introduction to Political Science	4
----------	-----------------------------------	---

And a choice of one of the following:

GOVT 101	National Government	4
GOVT 240	Contemporary Political Ideologies	4
GOVT 320	Third World Politics	4
GOVT 330	Mass Media Politics	4
GOVT 340	European Politics	4
GOVT 350	National Policy Issues	4
GOVT 399	Special Topics in Government OR	4
GOVT 499	Special Topics in Government	4

ECONOMICS

ECON 201	Principles of Microeconomics	4
ECON 202	Principles of Macroeconomics	4

And a choice of two of the following:

BUMG 340	International Business	4
BUMK 315	International Marketing	4
ECON 411	Comparative Economic Systems	4
ECON 450	International Trade	4

HISTORY

Choose one from the following:

HIST 310	Nazi Germany	4
HIST 325	History of Russia	4
HIST 330	History of Southern Africa	4
HIST 420	Middle East in Modern Times	4

GEOGRAPHY

Choose one from the following:

GEOG 125	World Geography	4
GEOG 201	Cultural Geography	4
GEOG 350	Regional Geography, North America	4
GEOG 351	Regional Geography, Middle East	4

ANTHROPOLOGY AND SOCIOLOGY

Choose one from the following:

ANTH 250	Prin. of Cultural Anthropology	4
HIST 371	Islamic Religion, Culture, & Civil.	4
SOCI 205	Current Social Problems	4
SOCI 312	Sociology of Religion	4
SOCI 410	Social Stratification	4

Foreign Language Requirement (12 Hours)

Any sequence of three courses in one language.

SPAN 111	Elementary Spanish 1	4
SPAN 112	Elementary Spanish 2	4
SPAN 113	Elementary Spanish 3	4
SPAN 211	Intermediate Spanish 1	4
SPAN 212	Intermediate Spanish 2	4
SPAN 213	Intermediate Spanish 3	4
FREN 111	Elementary French 1	4
FREN 112	Elementary French 2	4
FREN 113	Elementary French 3	4

Or a sequence in other languages as offered.

Elective Courses (70 Hours)

You may select from the broad spectrum of university courses or choose courses in the social sciences, business, and the humanities, especially foreign language. It is recommended that students consider minoring in economics, history, or business.

Special Notes

- Students must achieve a minimum grade of C in any courses required and elected in international relations or in the cognate concentration.
- Students concentrate on a single foreign language. The student may elect to take Option 2 of the general education non-western perspective. Option 2 will substitute the foreign language requirement of the major, in the case of French, until a 200-level sequence in French becomes available. Option 2 will not substitute for the foreign language requirement of the major in the case of Spanish; students will have to also take the 200-level sequence.
- Students are subject to all applicable degree and curricula rules and restrictions issued by the General Education Program and the Department of Social Science. Students should consult with their advisor.

Bachelor of Arts with a Major in Psychology

The Department of Social Sciences' psychology program provides students a general overview of the field of psychology. Students are introduced to research techniques, theories of learning, psychometrics, and a variety of other subfields of psychology.

Students are required to complete 32 hours from upper-division content courses, however, they are free to choose from any 300 or 400 level

psychology courses offered. Faculty advisors will encourage students to take courses that best suit their career interests.

This flexibility permits the student to concentrate in various career/graduate school interests such as clinical/counseling psychology, developmental psychology, social psychology, and experimental psychology.

Degree Requirements

General Education Program	48 Hours
<i>Psychology majors must take MATH 150 (Statistics) to satisfy the GEP Quantitative Reasoning Requirement. See page 55 for further information about the GEP.</i>	
Psychology Core Courses	24 Hours
Upper Division Psychology Courses	32 Hours
Social Science Upper-Division Cognate Courses	12 Hours
Elective Courses	70 Hours
Total Hours Required	186 Hours

Psychology Core Courses (24 Hours)

Course No.	Course	Cr. Hrs.
PSYC 101	Introduction to Psychology	4
PSYC 290	Psychological Tests & Measurements	4
PSYC 295	Quantitative Methods	4
PSYC 304	Psychology of Learning	4
PSYC 317	Developmental Psychology <i>(Talk to advisor about possible substitutions for this course.)</i>	4
PSYC 475	Psych. Study of Contemp. Problems	4

Upper Division Psychology Courses

Students, with the help of psychology advisors, must select a minimum of 32 hours from 300-400 level psychology courses to meet their interests and occupational needs. PSYC 430, Experimental Psychology, is strongly recommended for students who are considering graduate work in psychology.

Social Science Upper-Division Cognate Courses (12 Hours)

Students must choose courses from three different areas in order to fulfill the requirement.

ANTH 360	Indians of North America	4
ECON 350	Labor Economics	4
GEOG 310	Medical Geography	4
GOVT 330	Mass Media Politics	4
GOVT 350	National Policy Issues	4
HIST 320	Hist. of American Foreign Relations	4
HIST 401	History of Medicine	4
SOCI 305	Social Work Practice	4
SOCI 310	Gender Socialization	4
SOCI 312	Sociology of Religion	4
SOCI 320	Sociology of Culture	4
SOCI 325	Sociology of the Family	4

Special Notes

- Students must earn a C or higher grade in every course in the psychology major.
- Psychology courses taken on a pass/no pass basis will not count toward the major.
- Transfer students who have taken psychology courses at another institution must take at least 24 hours of upper division psychology courses at Shawnee State University.
- The chairperson must approve any variation from the required program.

Bachelor of Arts with a Major in Social Science

The general social science major requires 36 hours of social science core courses. You must achieve a minimum grade of C in each required social science course in order to graduate.

Some of the courses you choose to meet the requirement for the social science major may also count as General Education courses. See your advisor for further information.

Degree Requirements

General Education Program	48 Hours
<i>Social science majors must take SOSOC 110S to fulfill the GEP social science requirement. Further information is listed on page 55 of the current catalog or can be obtained from the dean's office.</i>	
Social Science Core Courses	36 Hours
Upper Division Social Science Electives (300-400 level)	36 Hours
Elective Courses	66 Hours
Total Hours Required	186 Hours

Social Science Core Courses (36 Hours)

Course No.	Course	Cr. Hrs.
PSYC 101	Introduction to Psychology	4
SOCI 101	Introduction to Sociology	4
GOVT 250	Introduction to Political Science	4
ECON 202	Principles of Macroeconomics <i>(or ECON 103 or ECON 201)</i>	4
ANTH 250	Prin. of Cult. Anth. <i>(or GEOG 125 or GEOG 130 or GEOG 201)</i>	4
HIST 111	American History <i>(or HIST 112 or HIST 113)</i>	4
HIST 201	Ancient or European History <i>(or HIST 202 or HIST 203)</i>	4
PSYC 273	Psychology of Human Adjustment	4
GOVT 401	State of the World	4

Upper Division Social Science Electives (36 Hours)

You may elect to choose courses at the 300 to 400 level from any social science (including psychology) category as follows:

- Anthropology (ANTH)
- Economics (ECON)
- Geography (GEOG)
- Government (GOVT)
- History (HIST)
- Psychology (PSYC)
- Sociology (SOCI)
- Social Science (SOSC)

Elective Courses (66 Hours)

Although electives may be chosen from the broad spectrum of university courses, you may choose to take your electives within the social science department (anthropology, geography, history, political science, psychology, and sociology) and pursue a broad emphasis in social science. With this approach, you acquire a comprehensive background in the social sciences. It is suggested that you take 8 to 12 hours from each of the following areas:

- History
- Economics
- Geography
- Government
- Psychology
- Sociology/Anthropology

Bachelor of Arts in Social Sciences

2+2 for Students Who Complete the Legal Assisting Program

This program is designed for students who have completed the associate degree in legal assisting at Shawnee State and who wish to pursue a baccalaureate degree as preparation for law school. All required courses in the legal assisting program (100 credit hours) count toward the baccalaureate requirements. To be awarded the bachelor degree, you must complete an additional 36 hours of General Education Program requirements, 28 hours of Social Science Core requirements, and 32 hours in social science at the 300-400 level. The entire program requires completion of 196 credit hours. You must achieve a minimum grade of C in each required social science course in order to graduate.

Some of the courses you choose to meet the requirement for the social science (2+2) major may also count as General Education courses. See your advisor for further information.

Degree Requirements

Completion of Legal Assist. Prog.	100 Hours
Additional General Ed. Program	36 Hours

Additional Social Sc. Core Courses	28 Hours
Upper Division Soc. Sc. Electives <i>(300-400 level)</i>	32 Hours

Total Hours Required 196 Hours

Legal Assisting Curriculum (100 Hours)

Includes certain courses that are part of either the General Education Program or the Social Science Core. (Refer to page 140 of the current catalog or contact the dean of the College of Professional Studies for more information).

Additional General Education Program (36 Hours)

This is the maximum number of hours. With doublecounting, the hours required may actually be less. Some General Education Program courses have already been taken within the legal assisting associate degree program. Please see your advisor to determine specifically what is required.

Additional Social Science Core (28 Hours)

Course No.	Course	Cr. Hrs.
SOCI 101	Introduction to Sociology	4
ECON 201	Prin. of Micro. <i>(or ECON 202)</i>	4
HIST 111	Amer. Hist. <i>(or HIST 112 or 113)</i>	4
HIST 201	Ancient or European History <i>(or HIST 202 or 203)</i>	4
PSYC 273	Psychology of Human Adjustment	4
GEOG 125	World Geography <i>(or GEOG 130 or 201 or ANTH 250)</i>	4
GOVT 401	State of the World	4

Upper Division Social Science Electives (32 Hours)

Select 32 credit hours of upper division social science electives (courses in anthropology, economics, geography, government, history, psychology, and/or sociology) in consultation with your faculty advisor.

Bachelor of Arts, Integrated Social Studies with Adolescent to Young Adult (Grades 7-12) Licensure

Degree Requirements

General Education Program <small>(48 Hours)</small>	40 Hours
<i>The Social Science component and four hours of the Cultural Perspectives component of the GEP are satisfied by the requirements of this degree. SOSC 110S and PHIL 320S are required.</i>	

Further information is listed on page 55 of the current catalog or can be obtained from the Department of Teacher Education.

Social Studies Component	80-92 Hours
Professional Education Core	20 Hours
Reading/Literature Requirement	8 Hours
Related Studies Component	12 Hours
Adolescent/Young Adult Courses	32 Hours

Total Hours Required:

Economics Concentration	201 Hours
Geography Concentration	201 Hours
Political Science Concent.	201 Hours
History Concentration	201-209 Hours
Psychology Concentration	197-205 Hours
Sociology Concentration	201 Hours

Social Studies Component (80-92 Hours)

Course No.	Course	Cr. Hrs.
ECON 201	Principles of Microeconomics	4
ECON 202	Principles of Macroeconomics	4
GEOG 125	World Geography	4
GEOG 201	Cultural Geography	4
GEOG 350	Regional Geography	4
GOVT 250	Introduction to Political Science	4
GOVT 370	Global Politics	4
GOVT 401	State of the World	4
HIST 113	American History Since 1900	4
HIST 201	Ancient History	4
HIST 350	Ohio History	4
PSYC 101	Intro. to Psychology <i>Met in related studies component</i>	
PSYC 151	Human Growth & Development	4
SOCI 101	Introduction to Sociology	4
SOCI 206	Social Institutions	4
SOCI 310	Gender Socialization	4
SOSC 110S	Foundations of Social Science	4

Select either:

HIST 111	American History to 1828	4
HIST 112	American History, 1828-1900	

Choose one of the following areas of concentration. Courses taken in the GEP and social studies components may fulfill selected requirements.

ECONOMICS CONCENTRATION (16 HOURS)

Met in social studies component:

ECON 201	Principles of Microeconomics
ECON 202	Principles of Macroeconomics

Select four:

ECON 301	Intermediate Microeconomics	4
ECON 302	Intermediate Macroeconomics	4
ECON 310	Money & Banking	4
ECON 320	History of Economic Thought	4
ECON 326	Economic History of the U.S.	4
ECON 332	Managerial Economics	4
ECON 350	Labor Economics	4

ECON 405	Economic Development	4
ECON 411	Comparative Economic Systems	4
ECON 425	Public Finance	4
ECON 480	Econometrics	4
ECON 499	Special Topics in Economics	4

GEOGRAPHY CONCENTRATION (16 HOURS)

GEOG 225	Physical Geography	4
----------	--------------------	---

Met in social studies component:

GEOG 125	World Geography
GEOG 201	Cultural Geography
GEOG 350	Regional Geography

Select one:

GEOG 130	Economic Geography	4
GEOG 227	Foundations of Meteorology	4
GEOG 230	Urban Geography	4
GEOG 242	Geography of Ohio	4

Select two:

GEOG 310	Medical Geography	4
GEOG 311	Air Pollution	4
GEOG 351	Regional Geog. of the Middle East	4
GEOG 404	Transportation Geog. & Mgt.	4

POLITICAL SCIENCE CONCENTRATION (16 HOURS)

Met in social studies component:

GOVT 250	Introduction to Political Science
GOVT 370	Global Politics

Select four:

GOVT 240	Contemporary Political Ideologies	4
GOVT 310	United States Foreign Policy	4
GOVT 320	Third World Politics	4
GOVT 330	Mass Media Politics	4
GOVT 340	European Politics	4
GOVT 350	National Policy Issues	4
GOVT 420	International Political Economy	4

HISTORY CONCENTRATION (16-24 HOURS)

Select two:

HIST 111 ¹	American History to 1828	0-4
HIST 112 ¹	American History, 1828-1900	

Select two:

HIST 201	Ancient History <i>Met in social studies component</i>	
HIST 202	Medieval & Early Modern Europe	4
HIST 203	Modern Europe	4

Select one:

HIST 301	Form. of the Am. Nation, 1750-1815	4
HIST 305	From FDR to Reagan	4
HIST 320	History of Am. Foreign Relations	4
HIST 326	Economic History of the U.S.	4

Select one:

HIST 310	Nazi Germany	4
HIST 325	History of Russia	4
HIST 401	History of Medicine	4
HIST 410	Intellectual History 1	4
HIST 411	Intellectual History 2	4

¹ One of these courses must be selected in the social studies component.

Select one:

ANTH 340	MesoAmerica Before Columbus	4
HIST 330	History of Southern Africa	4
HIST 371	Islamic Religion, Culture, & Civ.	4
HIST 420	Middle East in Modern Times	4

PSYCHOLOGY CONCENTRATION (12-20 HOURS)

PSYC 101	Intro. to Psychology <i>Met in related studies component</i>	
PSYC 151	Human Growth & Development <i>Met in social studies component</i>	
PSYC 290	Psychological Tests & Measurements	4

Select two:

PSYC 300	Theories of Personality	4
PSYC 303	Introduction to Social Psychology	4
PSYC 310	Child Psychology	4
PSYC 311	Human Sexuality	4
PSYC 316	Behavior Problems in Children	4
PSYC 360	Drugs/Substance Abuse	4
PSYC 361	Industrial Psychology	4
PSYC400	Abnormal Psychology	4
PSYC 405	Death and Dying	4

Select two (may be satisfied by related studies component):

PSYC 304	Psychology of Learning	0-4
PSYC 312	Adolescent Psychology	0-4
PSYC 375	Educational Psychology	
PSYC 380	Psyc. of Excep. Children & Youth	

SOCIOLOGY CONCENTRATION (16 HOURS)

SOCI 205	Current Social Problems	4
SOCI 303	Introduction to Social Psychology	4
SOCI 312	Sociology of Religion OR	4
SOCI 320	Sociology of Culture OR	
SOCI 330	Social Theory	
SOCI 325	Sociology of the Family	4

Met in social studies component:

SOCI 101	Introduction to Sociology	
SOCI 206	Social Institutions	
SOCI 310	Gender Socialization	

Professional Education Core (20 Hours)

EDUC 115	Intro. to the Teaching Profession	4
EDUC 230	Instructional Media, Technology, & Computers	4
EDUC 240	School & Society: Legal, Theoretical Philosophical, & Ethical Found. of American Education	4
EDUC 245	Teaching Individuals in a Pluralistic Society	4
EDUC 310	Strategies of Assessment, Diagnosis, & Evaluation in the Classroom	4

Reading/Literature Requirement (8 Hours)

EDRE 305	Teaching Reading in the Content Areas	4
ENGL 323	Adolescent Literature	4

Related Studies Component (12 Hours)

PSYC 101	Introduction to Psychology	4
PSYC 304	Psychology of Learning OR	4
PSYC 375	Educational Psychology	
PSYC 312	Adolescent Psychology	4

Adolescent/Young Adult Courses (32 Hours)

EDAE 285	Practicum & Seminar 1: Observation & Reflection in Professional Practice	4
EDAE 385	Pract. & Sem. 2: Action Research - Home, School, & Comm. Relations	4
EDAE 400	Prin. & Strategies of Curriculum Develop., Mgr., & Instruction	4
EDAE 485	Practicum & Seminar 3: Curriculum, Instruction, & Evaluation	4
EDAE 490	Directed Teaching & Seminar	12
SOCI 435	Teaching Social Studies in Grades 7-12	4

Special Note: The middle childhood license to teach social studies in grades 4-9 is found on pages 112 and 113 of this catalog.

Bachelor of Arts with a Major in Sociology

The Department of Social Sciences' sociology program provides students with a general overview of the field of sociology. All majors are introduced to the basic theories of sociology, research techniques, and data analysis, the interrelationship of society and culture, issues concerning modernity, and inequality. Sociology gives the student a grasp of the "global" nature of social relationships and allows one to understand the complex interplay between individuals, communities, organizations, nations, classes, racial groups, ethnic groups, and gender.

The degree offers students the ability to concentrate in the various subfields of sociology, which allows flexibility in the choice of careers and graduate school.

Degree Requirements

General Education Program	48 Hours
<i>Sociology majors must take MATH 150 (Statistics) to satisfy the GEP Quantitative Reasoning Requirement and must take SOSC 110S to satisfy the general education social science requirement. See page 55 for further information about the GEP.</i>	
Sociology Core Courses	24 Hours
Upper Division Sociology Courses	32 Hours
Social Science Upper-Division Cognate Courses	20 Hours
Elective Courses	62 Hours
Total Hours Required	186 Hours

Sociology Core Courses (24 Hours)

Course No.	Course	Cr. Hrs.
SOCI 101	Introduction to Sociology	4
SOCI 205	Current Social Problems	4

Course No.	Course	Cr. Hrs.
SOCI 206	Social Institutions	4
SOCI 330	Social Theory	4
SOCI 380	Sociological Methods	4
SOCI 410	Social Stratification	4

Upper Division Sociology Courses

Students, with the help of sociology advisors, must select a minimum of 32 hours from any sociology/anthropology upper level (300-400) courses.

Social Science Upper-Division Cognate Courses (20 Hours)

ANTH 360	Indians of North America	4
ECON 320	History of Economic Thought	4
ECON 350	Labor Economics	4
ECON 405	Economic Development	4
ECON 411	Comparative Economic Systems	4
GEOG 310	Medical Geography	4
GEOG 350	Geography of North America	4
GEOG 351	Regional Geog. of the Middle East	4
GOVT 310	American Foreign Policy	4
GOVT 320	Third World Politics	4
GOVT 330	Mass Media Politics	4
GOVT 340	European Politics	4
GOVT 350	National Policy Issues	4
GOVT 370	Global Politics	4
GOVT 401	State of the World	4
GOVT 420	International Political Economy	4
HIST 305	FDR to Reagan	4
HIST 310	Nazi Germany	4
HIST 325	Russian History	4
HIST 330	History of South Africa	4
HIST 371	Islamic Culture	4
HIST 401	History of Medicine	4
HIST 420	Middle East in Modern Times	4
SOSC 370	Alternative Religions and Cults	4

Special Notes

- Students must earn a C or higher grade in every course in the sociology major.
- Sociology courses taken on a pass/no pass basis will not count toward the major.
- Transfer students who have taken a major in sociology at another institution must take at least 24 hours of upper-division sociology courses at Shawnee State University in order to declare a major.
- Sociology majors must take MATH 150 to satisfy the General Education mathematics requirement and must take SOSC 110S to satisfy the General Education social science requirement.
- Students who have graduated from Shawnee State University in a major other than sociology and return to complete the major must meet all

degree requirements. Students who have met minimum degree requirements must complete at least 24 hours of upper-division sociology at SSU in order to receive an additional degree.

Please contact the Department of Social Sciences at 740.351.3234 for further information.

Minors

Students must be enrolled in a baccalaureate degree program in order to be eligible for a minor. All courses in each minor require a minimum grade of C. No more than 12 of these hours may count toward your major(s).

Economics

A minor in economics offers students enrolled in any of Shawnee State University's baccalaureate programs an opportunity to broaden their course of study with an auxiliary focus in economics. This is especially appealing to students interested in careers in banking, law, finance, or government service.

The minor requires you to complete 24 credit hours of economics, with a minimum grade of C. No more than 12 of these hours may count toward your major(s), and since ECON 201 and 202 are prerequisites for all upper-level economics courses, these are required for the minor. Any four additional upper-level economics courses will satisfy the hours requirement.

Geography

Students enrolled in a baccalaureate degree program in most arts and science and business majors may elect to complete a minor in geography. This may be an appropriate minor if you are interested in a career in marketing, tourism, environment, city planning, teaching, or the military.

The minor in geography requires the completion of 28 hours in geography. No grade below a C- will be permitted to count toward completion. Courses taken on a pass/no-credit basis may not be applied to the minor. No more than 12 of these hours may count toward your major(s).

Requirements

The following three courses are required (12 hours):

GEOG 125	World Geography
GEOG 201	Cultural Geography
GEOG 225	Physical Geography

Select one of the following (4 hours):

- GEOG 130 Economic Geography
 GEOG 230 Urban Geography
 GEOG 242 Geography of Ohio

Select three of the following (12 hours):

- GEOG 310 Medical Geography
 GEOG 311 Air Pollution
 GEOG 350 Regional Geography: North America
 GEOG 351 Regional Geography: Middle East
 GEOG 404 Transportation Geography and Management
 Other upper division geography courses as available.

History

Students enrolled in any of the University's baccalaureate degree programs may elect to complete a minor in history. This may be a particularly attractive program for those majoring in English/humanities, social sciences, or business and for those planning to attend law school.

The minor requires you to complete 28 hours of history, with a minimum grade of "C." Courses taken on a pass/no-credit basis may not be applied to the minor. No more than 12 of these hours may count toward your major(s).

Requirements

American History Survey Courses (8 Hours)

Select two

- HIST 111 American History to 1828
 HIST 112 American History, 1828-1900
 HIST 113 American History Since 1900

European History Survey Courses (8 Hours)

Select two

- HIST 201 Ancient History
 HIST 202 Medieval and Early Modern Europe
 HIST 203 Modern Europe

Upper-Level History Courses (12 Hours)

Select three courses, with no more than two courses from the same field. Note: both the number of fields and available courses within them may increase as the program develops.

FIELD ONE (U.S. HISTORY)

- HIST 301 Formation of the American Nation, 1750-1815
 HIST 305 From FDR to Reagan
 HIST 320 History of American Foreign Relations
 HIST 326 Economic History of the U.S.

FIELD TWO (EUROPEAN HISTORY)

- HIST 310 Nazi Germany
 HIST 325 History of Russia
 HIST 401 History of Medicine
 HIST 410 Intellectual History 1
 HIST 411 Intellectual History 2

FIELD THREE (NON-WESTERN HISTORY)

- ANTH 340 MesoAmerica Before Columbus
 HIST 330 History of South Africa
 HIST 360 East Asian History
 HIST 371 Islamic Culture and Civilization
 HIST 420 Middle East in Modern Times

Political Science

A minor in political science may be an appropriate choice for students pursuing a baccalaureate degree in most arts and science and business majors or for students interested in a career in the public sector, in journalism, public relations, trade, professional and research organizations, foundations, consulting and contracting firms, or political support groups.

The minor requires you to complete 24 hours in political science, with a minimum grade of C in any of the courses selected from the list below. You are subject to all applicable baccalaureate degree and curricula rules and restrictions issued by the academic departments and the General Education Program. No more than 12 of these hours may count toward your major(s).

Requirements

Choose any six courses from the list below. (Each is 4 credit hours.)

- GOVT 101 National Government
 GOVT 240 Contemporary Political Ideologies
 GOVT 310 United States Foreign Policy
 GOVT 320 Third World Politics
 GOVT 330 Mass Media Politics
 GOVT 340 European Politics
 GOVT 350 National Policy Issues
 GOVT 370 Global Politics
 GOVT 420 International Political Economy

Psychology

Graduates with a minor in psychology make attractive employment prospects because of their familiarity with the human condition. The American Psychological Association and the *Occupational Outlook Handbook* indicate that future employment opportunities for individuals with a psychology background may be found in business, industry, social services, marketing, public relations, criminology, and the health service field.

A "C" or better must be earned in the minor. Courses taken on a pass/no-credit basis do not count toward the minor. Any variation from the program must have the chairperson's approval.

Students are encouraged to take Principles of Statistics (MATH 150), Experimental Psychology (PSYC 430), and Psychological Study of Contemporary Problems (PSYC 475).

You may not count more than 12 credit hours of psychology taken in your major toward the minor in psychology.

Requirements (28 Hours)

PSYC 101	Introduction to Psychology
PSYC 151	Human Growth and Development
PSYC 290	Psychological Tests and Measurements
PSYC XXX	Electives (<i>16 credit hours with a minimum of 8 hours at the 300-400 level which relate to the student's area of interest.</i>)

Sociology

Students majoring in any discipline may choose to minor in sociology, which allows them to build a concentration in a behavioral science that enhances the marketability of their degree and prepares them for graduate school.

Sociology provides an excellent background for the development of careers in law, journalism, social services, recreation, counseling, and business. No more than 12 of these hours may count toward your major(s).

Requirements

Students must complete 28 hours of sociology courses. No more than 12 credit hours of sociology, from any BA degree, may be double counted toward the minor in sociology. Courses with grades below a C will not be counted toward the completion of the minor in sociology. Courses taken on a pass/no-credit basis are not applicable. Any variation from the program described requires advisor and chair approval. Students are encouraged to take MATH 150, Principles of Statistics.

Required Courses

SOCI 101	Introduction to Sociology
SOCI 205	Current Social Problems
SOCI 206	Social Institutions
SOCI 310	Gender Socialization OR
SOCI 410	Social Stratification

And select one from each of the following groupings.

GROUP 1

SOCI 224	Urban Sociology
SOCI 303	Introduction to Social Psychology
SOCI 307	Sociology of Work

GROUP 2

SOCI 310	Gender Socialization
SOCI 311	Human Sexuality
SOCI 325	Sociology of the Family
SOCI 405	Death and Dying

GROUP 3

ANTH 250	Principles of Cultural Anthropology
SOCI 312	Sociology of Religion
SOCI 320	Sociology of Culture
SOCI 340	Sociology of Appalachia
SOCI 429	Contemporary Minority Relations



TEACHER EDUCATION



Teacher Education

The Department of Teacher Education prepares students for careers in teaching, athletic training, or in the field of sports management. Degree and professional licensure programs are available in teaching as well as nonteaching areas for undergraduate students as well as persons wishing to enhance their employment options. Majors in athletic training and sports management, within the sports studies degree program, are designed to prepare students to enter careers in amateur and professional athletics.

The Department of Teacher Education at Shawnee State University is dedicated to preparing highly skilled educators and sports professionals at the undergraduate level and supporting professional development of practicing professionals. Whether you are just beginning your professional preparation or you are interested in enhancing your skills, the Department is here to help you meet your goals.

The Department of Teacher Education is accredited by the National Council for Accreditation of Teacher Education (NCATE)

For More Information

David E. Todt, Ph.D., Chairperson
Marcia Tackett, A.A., Preprofessional Services
Representative

Department of Teacher Education
Shawnee State University
940 Second Street
Portsmouth, Ohio 45662-4344

Phone: 740.351.3451

Fax: 740.351.3603

E-mail: mtackett@shawnee.edu

Programs and Licensure Offered by the Department of Teacher Education

Bachelor of Science in Education

with Licensure in:

Early Childhood (Grades PreK-3)

Early Childhood Intervention Specialist
(Grades PreK-3)

Middle Childhood (Grades 4-9)

Multiage Intervention Specialist (Grades K-12)

Bachelor of Science in Sports Studies

Athletic Training

Fitness Development

Sports Management

Adolescent to Young Adult (Grades 7-12)

Licensure

in conjunction with Shawnee State University's

Bachelor of Arts in English/Humanities

Integrated Language Arts

Bachelor of Arts in Social Sciences

Integrated Social Studies

Bachelor of Science in Mathematical Sciences

Integrated Mathematics

Bachelor of Science in Natural Science

Earth Science

Integrated Science

Life Science

Physical Science

Middle Childhood (Grades 4-9) Licensure

in conjunction with Shawnee State University's

Bachelor of Science in Natural Science

Mathematics and Science

Multiage Visual Arts Licensure (PreK-12)

in conjunction with Shawnee State University's

Bachelor of Fine Arts

Associate of Applied Science in Early Childhood Development

with Pre-Kindergarten Associate Licensure

Reading Endorsement

can be added to existing license

Certificate

Deaf Studies

Teacher Licensure Programs

Shawnee State University education students are prepared to become **learner-centered, inquiring professionals**. The teacher preparation programs require a strong foundation in an academic content or teaching area with the rigor of a professional development program, which prepares entry level teachers for the dynamic responsibilities of contemporary schools.

Today's teachers are required to continue their professional development throughout their careers. The vision of teaching which guides the teacher education program at Shawnee State is that of a

reflective and inquiring professional. Our program emphasizes lifelong learning in addition to the acquisition of specific skills and knowledge that are essential for an entry level teacher.

The knowledge base for all of the SSU teacher education programs is defined as five constituent domains of teacher capacity, including: 1) general studies and discipline area; 2) the diverse learner and learning process; 3) learning contexts and environments; 4) effective teaching strategies; and 5) professional development.

The education program provides a well-articulated arrangement of field and lab exercises designed to screen students for desired teacher qualities, provide a wide range of classroom experiences, and result in documentation of individual skills and experience in a professional portfolio. The teacher education program culminates in a student teaching experience that evaluates your professional competence and potential.

All of the licensure programs seek to lead you to a greater mastery of a teaching or professional specialization, an increased understanding of the liberal arts perspective, a research-based professional education core, and a greater sense of the need to contribute your abilities to the present community through your service and to future communities through your students' lives.

Preprofessional Services

The Office of Preprofessional Services provides assistance in the following areas to current and potential education students of Shawnee State University:

Student Recruitment
 Program Advising
 Field Experiences Placement
 Student Teaching Placement
 Graduate Follow-up
 Transfer Credit Review
 Program Admissions
 Examination Registration (PRAXIS Tests)
 Licensure

While appointments are recommended, students may drop in on an as-needed basis for information and assistance in any of the above areas. The office is located in the Department of Teacher Education suite on the second floor of Massie Hall.

For More Information

Paul M. Madden, M.Ed., Director

Debra Weber, M.A.Ed., Clinical and Field Experience Coordinator
 Marcia Tackett, A.A., Preprofessional Services Representative

Preprofessional Services
 Shawnee State University
 940 Second Street
 Portsmouth, Ohio 45662-4344
 Phone: 740.351.3547
 Fax: 740.351.3571
 E-mail: mtackett@shawnee.edu

Children's Learning Center

The Children's Learning Center (CLC) is a preschool which serves children that are three, four, or five years old. It is operated in conjunction with the Department of Teacher Education and is located on the campus of Shawnee State University. In addition to providing preschool and extended day child care services, the CLC functions as a laboratory school for the University's early childhood licensure programs.

For More Information

Cynthia Ferguson, M.Ed., Director
 Becky Herpy, Secretary
 Children's Learning Center
 Shawnee State University
 940 Second Street
 Portsmouth, OH 45662-4344
 Phone: 740.351.3252
 Fax: 740.351.3184
 E-mail: bherpy@shawnee.edu

Eligibility Criteria for Admission to Teacher Education

Admission to the University does not guarantee admission to teacher education. **Note:** Only EDUC 115 and 230 and EDEC 150 may be taken without admission to teacher education. To be considered for admission, a student must complete the following criteria:

- Satisfactory completion of at least 36 credit hours of university/college coursework
- 2.75 overall GPA
- Appropriate grade point average as required:
Completed GEP courses – a grade of C or higher (*ENGL 111S, 112S, 115S, and quantitative reasoning course required*)

Completed Related Studies courses – a grade of C or higher (*PSYC 101 required*)

Completed Professional Education courses – 3.0 average and a grade of C or higher (*EDUC 115 is required*)

Completed Content courses – 3.0 average

- Satisfactory evaluations for field and lab experiences in EDUC 115
- Satisfactory scores on all portions of the PRAXIS I Examinations

Reading/Writing/Mathematics – 172 each

- Satisfactory progress toward professional portfolio development with successful review from EDUC 115 faculty
- Completed statement of good moral character
- Complete first background clearance investigation (early childhood and early childhood intervention specialist students complete additional background/health packet)

Students will be granted **full admission** or will **not be admitted**.

- Students receiving full admission may continue to take coursework toward their licensure programs and are eligible to register for education courses as they meet necessary prerequisites.

Special Note:

Admission to teacher education does not guarantee admission to a licensure program, to student teaching, or recommendation for teacher licensure. Please consult the Teacher Education Handbook and a faculty advisor for licensure program admission, eligibility for student teaching, and for teacher licensure. The Teacher Education Handbook has detailed requirements for admission and retention.

Portfolio Requirement

Teacher preparation at Shawnee State University is a performance-based program. All students are required to demonstrate the knowledge, skills, and dispositions associated with the five domains of teacher capacity. The SSU teacher candidate:

- Is well grounded in general studies and specific discipline area(s)
- Understands the nature of human development and learning in working with diverse learners
- Demonstrates sensitivities to learning contexts and environments

- Employs effective teaching strategies to ensure the learning outcome
- Practices professionalism (i.e. appropriate attire and behavior in schools)

A significant amount of the evidence of teacher candidate performance is maintained through a required professional portfolio. With each course and at every level, students are required to collect items for their portfolio, provide reasons for including the item in the portfolio, and organize the portfolio to demonstrate their professional preparation for teaching.

PRAXIS Series Tests

Shawnee State University utilizes the PRAXIS series as one element of our student assessment program. Students complete the PRAXIS I prior to admission to teacher education; PRAXIS II Content/Specialty Area test prior to student teaching; PRAXIS II Principles of Learning and Teaching prior to earning a provisional license; and PRAXIS III prior to professional licensure. PRAXIS I and II are standardized tests completed at testing centers. PRAXIS III is a performance assessment completed during the entry year teaching experience. A trained assessor conducts PRAXIS III in the entry year teacher's classroom.

Registration booklets are available from the Department of Teacher Education. Test dates are limited and should be planned well in advance. Score reports are received within four to six weeks after test completion. Students should have their registration forms reviewed by department staff prior to mailing. The tests are expensive and any inaccurate information on the registration form could result in a delay or a nonreport of test scores. Visit the Educational Testing Service (ETS) on the web at www.ets.org/praxis.

Transfer, Postbaccalaureate, SSU Graduates Policy

Transfer students should review this catalog for transfer credit information. A grade of C or higher is required for all transfer credit. No exceptions will be made for any student entering a teacher preparation program. Grades earned at the student's previous institution will be used in determining program GPA requirements.

Postbaccalaureate and alternative licensure students who graduated from an accredited institution with an overall GPA of 2.75 or higher in

an appropriate content area may register for licensure only. The programs leading to adolescent to young adult licensure are best suited for post-baccalaureate students. Because our program is primarily an undergraduate, initial licensure program, a postbaccalaureate option for licensure does not currently exist. PRAXIS II content test must be passed prior to admission to the adolescent to young adult licensure program.

Any deficient areas must be met prior to recommendation for licensure. All applicable GPA and minimum grade requirements apply. Students registering for the licensure only option do not earn a degree from Shawnee State University; all coursework applies only to licensure requirements regardless of credit hours earned. A postbaccalaureate student who feels s/he may be eligible to earn the bachelor's degree may have his/her program reviewed and credit transferred into a degree program.

SSU graduates who have not begun the teacher preparation program are considered postbaccalaureate students and are required to meet the same guidelines listed previously.

Students who began their professional preparation at Shawnee State as undergraduates must meet the applicable undergraduate program requirements.

Bachelor of Science in Education with Licensure in Early Childhood (Grades PreK-3)

Degree Requirements

General Education Program	48 Hours
<i>GEOG 201, IDST 225S or 226S, MATH 110S, NTSC 110S, PHIL 320S, PSCI 251, and SOSC 110S are required. Further information is listed on page 55 of the current catalog or can be obtained from the Department of Teacher Education.</i>	
Professional Education Core	20 Hours
Reading Requirement	18 Hours
Related Studies Component	16 Hours
Early Childhood Courses	60 Hours
Curriculum Content	34 Hours
Total Hours Required	196 Hours

Professional Education Core (20 Hours)

Course No.	Course	Cr. Hrs.
EDUC 115	Intro. to the Teaching Profession	4
EDUC 115L		
EDUC 230	Instructional Media, Technology, & Computers	4

EDUC 240	School & Society: Legal, Theoretical Philosophical, & Ethical Found. of American Education	4
EDUC 245	Teaching Individuals in a Pluralistic Society	4
EDUC 310	Strategies of Assessment, Diagnosis, & Evaluation in the Classroom	4

Reading Requirement (18 Hours)

EDRE 302	Foundations of Literacy	5
EDRE 304	Teaching Phonics: Reading, Writing, & Spelling	5
EDRE 305	Teaching Reading in the Content Areas	4
ENGL 300	Children's Literature	4

Related Studies Component (16 Hours)

PSYC 101	Introduction to Psychology	4
PSYC 151	Human Growth & Dvlpmnt. OR	4
PSYC 310	Child Psychology	
SOCI 303	Intro. to Social Psychology OR	4
SOCI 320	Sociology of Culture OR	
SOCI 325	Sociology of Family	
PSYC 304	Psychology of Learning OR	4
PSYC 375	Educational Psychology	

Early Childhood Courses (60 Hours)

EDEC 150	Introduction to Early Childhood	4
EDEC 255	Educational Environments	4
EDEC 280	Administration of Early Childhood Programs	4
EDEC 283	Interprofessional & Parental Team Models	4
EDEC 284	Basic Movement for Children	4
EDEC 285	Practicum & Seminar 1:	4
EDEC 285L	Observation & Reflection in Professional Practice	
EDEC 385	Practicum & Seminar 2: Action	4
EDEC 385L	Research - Home, School, & Community Relations	
EDEC 400	Teaching Creative Expressions for Early Childhood	4
EDEC 415	Teaching Dev. Math & Science for Early Learners	4
EDEC 420	Teaching Dev. Language Arts & Social Studies for Early Learners	4
EDEC 485	Practicum & Seminar 3: Curric.,	4
EDEC 485L	Instruction, & Evaluation	
EDEC 490	Directed Teaching & Seminar	12
EDIS 250	Survey of Exceptionalities	4

Curriculum Content (34 Hours)

ARTP 201	Art in the Curriculum	3
GEOG 225	Physical Geography	4
GOVT 101	National Government	4
HIST 111	American History to 1828 OR	4
HIST 112	American History, 1828-1900 OR	
HIST 113	American History Since 1900	
MATH 140	Elem. Topics in Mathematics 1	4
MATH 141	Elem. Topics in Mathematics 2	4
MATH 305	Math Enrichment for the Teacher	4
MUSI 160	Fundamentals of Music	3
SSPE 202	Health & Nutri. Across the Lifespan	4

Bachelor of Science in Education with Licensure in Early Childhood Intervention Specialist (Grades PreK-3)

Degree Requirements

General Education Program <i>GEOG 201, IDST 225S or 226S, MATH 110S, NTSC 110S, PHIL 320S, PSCI 251, and SOSC 110S are required. Further information is listed on page 55 of the current catalog or can be obtained from the Department of Teacher Education.</i>	48 Hours
Professional Education Core <i>See page 111 of current catalog.</i>	20 Hours
Reading Requirement <i>See page 111 of current catalog.</i>	18 Hours
Related Studies Component	20 Hours
Intervention Specialist Courses	67 Hours
Curriculum Content	26 Hours
Total Hours Required	199 Hours

Related Studies Component (20 Hours)

Course No.	Course	Cr. Hrs.
PSYC 101	Introduction to Psychology	4
PSYC 151	Human Growth & Development	4
PSYC 304	Psychology of Learning OR	4
PSYC 375	Educational Psychology	4
PSYC 310	Child Psychology	4
PSYC 316	Behavior Problems in Children	4

Intervention Specialist Courses (67 Hours)

EDEC 255	Educational Environments	4
EDEC 400	Teaching Creative Expressions for Early Childhood	4
EDEC 415	Teaching Dev. Math & Science for Early Learners	4
EDEC 420	Teaching Dev. Language Arts & Social Studies for Early Learners	4
EDIS 250	Survey of Exceptionalities	4
EDIS 252	Movement, Health Issues, & Adaptive Technology	5
EDIS 283	Interprofessional & Parental Team Models in Special Education	4
EDIS 285	Practicum & Seminar 1: Observation & Reflection in Professional Practice	4
EDIS 311	Fundamentals of Special Education	5
EDIS 385	Pract. & Sem. 2: Action Research - Home, School, & Comm. Relations	4
EDIS 390	Behavior Mgt., Theorists, & Models	5
EDIS 423	The Intervention Specialist at the Early Childhood Level	4
EDIS 485	Practicum & Seminar 3: Curric., Instruction, & Evaluation	4
EDIS 490	Directed Teaching & Seminar	12

Curriculum Content (26 Hours)

ARTP 201	Art in the Curriculum	3
GEOG 225	Physical Geography	4

GOVT 101	National Government	4
HIST 111	American History to 1828 OR	4
HIST 112	American History, 1828-1900 OR	
HIST 113	American History Since 1900	
MATH 140	Elem. Topics in Mathematics 1	4
MATH 141	Elem. Topics in Mathematics 2	4
MUSI 160	Fundamentals of Music	3

Bachelor of Science in Education with Licensure in Middle Childhood (Grades 4-9)

Students pursuing the middle childhood license to teach mathematics and science may select from one of two degrees. In addition to this bachelor of science in education, a bachelor of science in natural science is available. See page 92 of this catalog. Consult an advisor in science, mathematics, or education to discuss which option best meets your needs.

Degree Requirements

General Education Program (48 Hours) <i>Certain components of the GEP are satisfied by the requirements of the bachelor of science in education. Further information is listed on page 55 of the current catalog or can be obtained from the Department of Teacher Education.</i>	32-36 Hours
Professional Education Core <i>See page 111 of current catalog.</i>	20 Hours
Reading Requirement <i>See page 111 of current catalog.</i>	18 Hours
Related Studies Component	12 Hours
Middle Childhood Courses	36 Hours
Content Component	81-88 Hours
Total Hours Required	203-208 Hours

Related Studies Component (12 Hours)

Course No.	Course	Cr. Hrs.
PSYC 101	Introduction to Psychology	4
PSYC 304	Psychology of Learning OR	4
PSYC 375	Educational Psychology	4
PSYC 312	Adolescent Psychology	4

Middle Childhood Courses (36 Hours)

EDMC 285	Practicum & Seminar 1: Observation & Reflection in Professional Practice	4
EDMC 385	Pract. & Semi. 2: Action Research - Home, School, & Comm. Relations	4
EDMC 470	Instructional Strategies & Mgt. for Integrated Curriculum	4
EDMC 485	Practicum & Seminar 3: Curric., Instruction, & Evaluation	4
EDMC 490	Directed Teaching & Seminar	12

Select the two appropriate courses for content component:

EDMC 472	Teaching Language Arts in Middle Grades	4
----------	---	---

EDMC 473	Teaching Math. in Middle Grades	4
EDMC 475	Teaching Social Studies in Middle Grades	4
EDMC 476	Teaching Science in Middle Grades	4

Content Component (81-88 Hours)

Select two areas of concentration

LANGUAGE ARTS AND READING (44 HOURS)

ENGL 200	Introduction to Literature	4
ENGL 211	Survey of English Literature	4
ENGL 232	Creative Writing (Poetry) OR	4
ENGL 245	Creative Writing (Fiction) OR	
JOUR 231	News Reporting & Writing	
ENGL 251	Survey of American Literature 1 OR	4
ENGL 252	Survey of American Literature 2	
ENGL 305	Advanced Expository Writing OR	4
ENGL 315	Theory & Prac. in Composition	
ENGL 362	Patterns of English	4
IDST 225S	Civilization & Literature 1	4
JOUR 105	Introduction to Mass Communication	4
SPCH 220	Oral Interpretation of Literature	4
THAR 100	Introduction to Theater	4

Select one

ENGL 205	Introduction to Women's Studies	4
ENGL 249	Native American Literature	4
ENGL 340	Literature of the Americas	4
ENGL 341	Literature of Initiation & Experience	4
ENGL 342	Women in Literature	4
ENGL 343	Black Authors	4
ENGL 344	Literature of Appalachia	4

SOCIAL STUDIES (44 HOURS)

ECON 202	Principles of Macroeconomics	4
GEOG 125	World Geography	4
GEOG 350	Regional Geography: North America	4
GOVT 101	National Government	4
GOVT 370	Global Politics	4
HIST 111	American History to 1828	4
HIST 112	American History, 1828-1900	4
HIST 113	American History Since 1900	4
HIST 350	Ohio History	4
SOCI 310	Gender Socialization	4
SOSC 110S	Intro. to Social Science	4

MATHEMATICS (40-41 HOURS)

MATH 110S	Mathematics Core Course	4
MATH 132	Precalculus 2 AND	4
MATH 190	Brief Calculus with Appl. OR	4
MATH 201	Calculus 1 AND	
MATH 202	Calculus 2	
MATH 140	Elem. Topics in Mathematics 1	4
MATH 141	Elem. Topics in Mathematics 2	4
MATH 150	Principles of Statistics OR	4
MATH 250	Statistics 1	
MATH 220	Discrete Mathematics OR	4-5
MATH 230	Linear Algebra	
MATH 300	History of Mathematics	4
MATH 305	Math. Enrichment for the Teacher	4
MATH 320	Foundation of Geometry	4

SCIENCE (41-44 HOURS)

BIOL 151	Principles of Biology	5
CHEM 121	Introduction to General Chemistry 1	4
CHEM 122	Introduction to General Chemistry 2	4
GEOL 111	Rocks, Minerals, & Fossils	4
NTSC 110S	Scientific Reasoning & Methodology	4
PSCI 251	Physical Science by Inquiry 1	4
PSCI 252	Physical Science by Inquiry 2	4

Select three:

BIOL 162	Human Anatomy & Physiology	5
BIOL 202	Principles of Plant Biology	5
BIOL 203	Principles of Animal Biology	5
BIOL 210	Taxonomy of Vascular Plants	4
BIOL 271	Field Ornithology	4
BIOL 272	Ohio's Natural Heritage	4
BIOL 302	Dendrology	4
BIOL 303	Spring Flora	4
BIOL 307	General Entomology	5
BIOL 370	Marine Biology	5
GEOL 112	Environmental Geology	4
GEOL 201	Physical Geology	4
GEOL 202	Historical Geology	4
GEOL 301	Invertebrate Paleobiology	4

Bachelor of Science in Education with Licensure in Multiage Intervention Specialist (Grades K-12)

Degree Requirements

General Education Program	48 Hours
<i>GEOG 201, IDST 225S or 226S, MATH 110S, NTSC 110S, PHIL 320S, PSCI 251, and SOSC 110S are required. Further information is listed on page 55 of the current catalog or can be obtained from the Department of Teacher Education.</i>	
Professional Education Core	20 Hours
<i>See page 111 of current catalog.</i>	
Reading Requirement	18 Hours
<i>See page 111 of current catalog.</i>	
Related Studies Component	16 Hours
Intervention Specialist Courses	55 Hours
Curriculum Content	30 Hours
Total Hours Required	187 Hours

Related Studies Component (16 Hours)

Course No.	Course	Cr. Hrs.
PSYC 101	Introduction to Psychology	4
PSYC 151	Human Growth & Development	4
PSYC 304	Psychology of Learning OR	4
PSYC 375	Educational Psychology	
PSYC 316	Behavior Problems in Children	4

Intervention Specialist Courses (55 Hours)

Course No.	Course	Cr. Hrs.
EDIS 250	Survey of Exceptionalities	4
EDIS 252	Movement, Health Issues, & Adaptive Technology	5
EDIS 283	Interprofessional & Parental Team Models in Special Education	4
EDIS 285	Practicum & Seminar 1: Observation & Reflection in Professional Practice	4
EDIS 311	Fundamentals of Special Ed.	5
EDIS 385	Pract. & Sem. 2: Action Research - Home, School, & Comm. Relations	4
EDIS 390	Behavior Mgr., Theorists, & Models	5
EDIS 423	The Intervention Specialist at the Early Childhood Level	4
EDIS 425	Instruc. Strat. & Curric. Design in a Continuum of Ed. Environ.	4
EDIS 485	Practicum & Seminar 3: Curric., Instruction, & Evaluation	4
EDIS 490	Directed Teaching & Seminar	12

Curriculum Content (30 Hours)

ARTP 201	Art in the Curriculum	3
GEOG 225	Physical Geography	4
GOVT 101	National Government	4
HIST 111	American History to 1828 OR	4
HIST 112	American History, 1828-1900 OR	
HIST 113	American History Since 1900	
MATH 140	Elem. Topics in Mathematics 1	4
MATH 141	Elem. Topics in Mathematics 2	4
MATH 305	Math Enrichment for the Teacher	4
MUSI 160	Fundamentals of Music	3

Adolescent to Young Adult (Grades 7-12) Licensure, Integrated Language Arts in Conjunction with the Bachelor of Arts in English/Humanities

Degree Requirements

General Education Program	48 Hours
<i>PHIL 320S and THAR 100 are required. Further information is listed on page 55 of the current catalog or can be obtained from the Department of Teacher Education.</i>	
Language Arts Component	76 Hours
Professional Education Core	20 Hours
<i>See page 111 of current catalog.</i>	
Reading Requirement	8 Hours
Related Studies Component	12 Hours
Adolescent/Young Adult Courses	32 Hours
Total Hours Required	196 Hours

Language Arts Component (76 Hours)

LANGUAGE EMPHASIS

Course No.	Course	Cr. Hrs.
ENGL 360	Intro. to Language & Linguistics	4
ENGL 362	Patterns of English	4

READING EMPHASIS

ENGL 200	Introduction to Literature	4
ENGL 211	Survey of English Literature 1	4
ENGL 212	Survey of English Literature 2	4
ENGL 251	Survey of American Literature 1	4
ENGL 252	Survey of American Literature 2	4
ENGL 301	Shakespeare 1 OR	4
ENGL 302	Shakespeare 2	

Select two

ENGL 205	Introduction to Women's Studies	4
ENGL 249	Native American Literature	4
ENGL 340	Literature of the Americas	4
ENGL 341	Literature of Initiation & Experience	4
ENGL 342	Women in Literature	4
ENGL 343	Black Authors	4
ENGL 344	Literature of Appalachia	4

Select one

ENGL 311	Major Engl. Authors (Before 1800)	4
ENGL 321	The English Novel	4
ENGL 322	Modern English Drama	4
ENGL 411	16th Century Renaissance Literature	4
ENGL 421	17th Century Poetry & Prose	4
ENGL 441	The Romantics	4
ENGL 446	The Victorians	4

WRITING EMPHASIS

ENGL 305	Advanced Expository Writing OR	4
ENGL 315	Theory & Practice in Composition	
ENGL 232	Creative Writing (Poetry) OR	4
ENGL 240	Screenwriting OR	
ENGL 245	Creative Writing (Fiction)	
JOUR 231	News Reporting & Writing	4

LISTENING/VISUAL LITERACY EMPHASIS

ENGL 105	Information Access	1
JOUR 105	Intro. to Mass Communication	4
PHIL 105	Rhetoric & Reasoning	4

ORAL COMMUNICATION EMPHASIS

SPCH 103	Public Speaking & Human Comm.	3
SPCH 220	Oral Interpretation of Literature	4

CAPSTONE

ENGL 485	Sr. Exp. for English/Hum. Majors	4
----------	----------------------------------	---

Reading Requirement (8 Hours)

EDRE 305	Teaching Reading in the Content Areas	4
ENGL 323	Adolescent Literature	4

Related Studies Component (12 Hours)

PSYC 101	Introduction to Psychology	4
PSYC 304	Psychology of Learning OR	4
PSYC 375	Educational Psychology	
PSYC 312	Adolescent Psychology	4

Adolescent/Young Adult Courses (32 Hours)

EDAE 285	Practicum & Seminar 1: Observation & Reflection in Professional Practice	4
EDAE 385	Pract. & Sem. 2: Action Research - Home, School, & Comm. Relations	4
EDAE 400	Prin. & Strategies of Curriculum Develop., Mgt., & Instruction	4
EDAE 485	Practicum & Seminar 3: Curric., Instruction, & Evaluation	4
EDAE 490	Directed Teaching & Seminar	12
ENGL 434 ¹	Methods of Teaching Language Arts in the Secondary Schools OR	4
MATH 470 ¹	Teaching Mathematics in Grades 7-12 OR	
SOCI 435 ¹	Teaching Social Sciences in Grades 7-12 OR	
NTSC 433 ¹	Teaching Science in Grades 7-12	

Adolescent to Young Adult (Grades 7-12) Licensure, Integrated Mathematics in Conjunction with the Bachelor of Science in Mathematical Sciences

Degree Requirements

General Education Program (48 Hours)	44 Hours
<i>The Quantitative Reasoning component of the GEP is satisfied by the requirements of the bachelor of science in mathematical sciences. See page 55 for further information about the GEP.</i>	
Integrated Math Component	65 Hours
Professional Education Core	20 Hours
<i>See page 111 of current catalog.</i>	
Reading Requirement	8 Hours
<i>See page 114 of current catalog.</i>	
Related Studies Component	16 Hours
Adolescent/Young Adult Courses	32 Hours
<i>See above.</i>	
General Elective	1 Hour
Total Hours Required	186 Hours

Integrated Math Component (65 Hours)

Course No.	Course	Cr. Hrs.
MATH 201	Calculus 1	4
MATH 202	Calculus 2	4
MATH 203	Calculus 3	4
MATH 204	Calculus 4	4
MATH 220	Discrete Mathematics	4
MATH 230	Linear Algebra	5
MATH 250	Statistics 1	4
MATH 300	History of Mathematics	4

MATH 301	Ordinary Differential Equations OR	4
MATH 430	Numerical Analysis	
MATH 320	Foundations of Geometry	4
MATH 360	Introduction to Probability	4
MATH 405	Math. Enrich. for the Sec. Teacher	4
MATH 410	Modern Algebra 1	4
MATH 411	Modern Algebra 2	4
MATH 440	Mathematical Models OR	4
MATH 370	Operations Research 1	
MATH 496	Senior Research Project 1	1
MATH 497	Senior Research Project 2	2
MATH 498	Senior Research Project 3	1

Related Studies Component (16 Hours)

BUIS/ETCO	Computer Science Elective See page 81.	4
PSYC 101	Introduction to Psychology	4
PSYC 304	Psychology of Learning OR	4
PSYC 375	Educational Psychology	
PSYC 312	Adolescent Psychology	4

Adolescent to Young Adult (Grades 7-12) Licensure, Integrated Social Studies in Conjunction with the Bachelor of Arts in Social Sciences

Degree Requirements

General Education Program (48 Hours)	40 Hours
<i>The Social Science component and four hours of the Cultural Perspectives component of the GEP are satisfied by the requirements of this degree. SOSC 110S and PHIL 320S are required. Further information is listed on page 55 of the current catalog or can be obtained from the Department of Teacher Education.</i>	
Social Studies Component	80-92 Hours
Professional Education Core	20 Hours
<i>See page 111 of current catalog.</i>	
Reading Requirement	8 Hours
<i>See page 114 of current catalog.</i>	
Related Studies Component	12 Hours
<i>See page 114 of current catalog.</i>	
Adolescent/Young Adult Courses	32 Hours
<i>See left column, this page.</i>	

Total Hours Required:

Economics Concentration	196 Hours
Geography Concentration	196 Hours
Political Science Concent.	196 Hours
History Concentration	196-204 Hours
Psychology Concentration	192-200 Hours
Sociology Concentration	196 Hours

¹ Methods course appropriate to specific licensure.

Social Studies Component (80-92 Hours)

Course No.	Course	Cr. Hrs.
ECON 201	Principles of Microeconomics	4
ECON 202	Principles of Macroeconomics	4
GEOG 125	World Geography	4
GEOG 201	Cultural Geography	4
GEOG 350	Regional Geography	4
GOVT 250	Introduction to Political Science	4
GOVT 370	Global Politics	4
GOVT 401	State of the World	4
HIST 113	American History Since 1900	4
HIST 201	Ancient History	4
HIST 350	Ohio History	4
PSYC 101	Intro. to Psychology <i>Met in related studies component</i>	4
PSYC 151	Human Growth & Development	4
SOCI 101	Introduction to Sociology	4
SOCI 206	Social Institutions	4
SOCI 310	Gender Socialization	4
SOSC 110S	Foundations of Social Science	4

Select either:

HIST 111	American History to 1828	4
HIST 112	American History, 1828-1900	4

Choose one of the following areas of concentration. Courses taken in the GEP and social studies components may fulfill selected requirements.

ECONOMICS CONCENTRATION (16 HOURS)

Met in social studies component:

ECON 101	Principles of Macroeconomics	
ECON 102	Principles of Microeconomics	

Select four:

ECON 301	Intermediate Microeconomics	4
ECON 302	Intermediate Macroeconomics	4
ECON 310	Money and Banking	4
ECON 320	History of Economic Thought	4
ECON 326	Economic History of the U.S.	4
ECON 332	Managerial Economics	4
ECON 350	Labor Economics	4
ECON 405	Economic Development	4
ECON 411	Comparative Economic Systems	4
ECON 425	Public Finance	4
ECON 480	Econometrics	4
ECON 499	Special Topics in Economics	4

GEOGRAPHY CONCENTRATION (16 HOURS)

GEOG 225	Physical Geography	4
----------	--------------------	---

Met in social studies component:

GEOG 125	World Geography	
GEOG 201	Cultural Geography	
GEOG 350	Regional Geography	

Select one:

GEOG 130	Economic Geography	4
GEOG 227	Foundations of Meteorology	4
GEOG 230	Urban Geography	4
GEOG 242	Geography of Ohio	4

Select two:

GEOG 310	Medical Geography	4
GEOG 311	Air Pollution	4
GEOG 351	Regional Geog. of the Middle East	4
GEOG 404	Transportation Geog. & Mgt.	4

POLITICAL SCIENCE CONCENTRATION (16 HOURS)

Met in social studies component:

GOVT 250	Intro. to Political Science	
GOVT 370	Global Politics	

Select four:

GOVT 240	Contemporary Political Ideologies	4
GOVT 310	United States Foreign Policy	4
GOVT 320	Third World Politics	4
GOVT 330	Mass Media Politics	4
GOVT 340	European Politics	4
GOVT 350	National Policy Issues	4
GOVT 420	International Political Economy	4

HISTORY CONCENTRATION (16-24 HOURS)

Select two:

HIST 111 ¹	American History to 1828	0-4
HIST 112 ¹	American History, 1828-1900	
HIST 113	American History Since 1900	

Met in social studies component

Select two:

HIST 201	Ancient History <i>Met in social studies component</i>	
HIST 202	Medieval & Early Modern Europe	4
HIST 203	Modern Europe	4

Select one:

HIST 301	Form. of the Am. Nation, 1750-1815	4
HIST 305	From FDR to Reagan	4
HIST 320	Hist. of American Foreign Relations	4
HIST 326	Economic History of the U.S.	4

Select one:

HIST 310	Nazi Germany	4
HIST 325	History of Russia	4
HIST 401	History of Medicine	4
HIST 410	Intellectual History 1	4
HIST 411	Intellectual History 2	4

Select one:

ANTH 340	MesoAmerica Before Columbus	4
HIST 330	History of Southern Africa	4
HIST 371	Islamic Religion, Culture, & Civ.	4
HIST 420	Middle East in Modern Times	4

PSYCHOLOGY CONCENTRATION (12-20 HOURS)

PSYC 101	Intro. to Psychology <i>Met in related studies component</i>	
PSYC 151	Human Growth & Development	

Met in social studies component

PSYC 290	Psychological Tests & Measurements	4
----------	------------------------------------	---

Select two:

PSYC 300	Theories of Personality	4
PSYC 303	Introduction to Social Psychology	4
PSYC 310	Child Psychology	4
PSYC 311	Human Sexuality	4
PSYC 316	Behavior Problems in Children	4

¹ One of these courses must be selected in the social studies component.

PSYC 360	Drugs/Substance Abuse	4
PSYC 361	Industrial Psychology	4
PSYC400	Abnormal Psychology	4
PSYC 405	Death & Dying	4

Select two (may be satisfied by related studies component):

PSYC 304	Psychology of Learning	0-4
PSYC 312	Adolescent Psychology	0-4
PSYC 375	Educational Psychology	

SOCIOLOGY CONCENTRATION (16 HOURS)

SOCI 205	Current Social Problems	4
SOCI 303	Introduction to Social Psychology	4
SOCI 312	Sociology of Religion OR	4
SOCI 320	Sociology of Culture OR	
SOCI 330	Social Theory	
SOCI 325	Sociology of the Family	4

Met in social studies component:

SOCI 101	Introduction to Sociology	
SOCI 206	Social Institutions	
SOCI 310	Gender Socialization	

Adolescent to Young Adult (Grades 7-12) Licensure, Earth, Life, or Physical Science in Conjunction with the Bachelor of Science in Natural Science

Degree Requirements

General Education Program (48 Hours)	36 Hours
<i>The Quantitative Reasoning and Natural Science components of the GEP are satisfied by the requirements of the bachelor of science in natural science. Further information is listed on page 55 of the current catalog or can be obtained from the Department of Teacher Education.</i>	
Science Component	83-93 Hours
Professional Education Core	20 Hours
<i>See page 111 of current catalog.</i>	
Reading Requirement	8 Hours
<i>See page 114.</i>	
Related Studies Component	16 Hours
<i>See page 114.</i>	
Adolescent/Young Adult Courses	32 Hours
<i>See page 115.</i>	

Total Hours Required:

Earth Science	197 Hours
Life Science	195-196 Hours
Physical Science	205 Hours

Science Component (83-93 Hours)

Choose one science component from among the following:

EARTH SCIENCE (85 HOURS)

Course No.	Course	Cr. Hrs.
BIOL 151	Principles of Biology	5
BIOL 370	Marine Biology	5
CHEM 141	General Chemistry 1	5
CHEM 142	General Chemistry 2	5
CHEM 143	General Chemistry 3	5
GEOG 311	Air Pollution OR	4
GEOG 227	Foundations of Meteorology	
GEO 111	Rocks, Minerals, & Fossils	4
GEO 112	Environmental Geology	4
GEO 201	Physical Geology	4
GEO 202	Historical Geology	4
GEO 301	Invertebrate Paleobiology OR	4
GEO 303	Sedimentary Rocks	
GEO 302	Mineralogy	4
GEO 401	Field Methods	4
GEO 485	Senior Project	4
MATH 131	College Algebra or higher	4
MATH 150	Principles of Statistics OR	4
MATH 250	Statistics 1	
MATH 190	Brief Calculus with Applications	4
NTSC 110S	Scientific Reasoning & Methodology	4
PHYS 210	Astronomy	4
PSCI 251	Physical Science by Inquiry 1	4

LIFE SCIENCES (83-84 HOURS)

BIOL 151	Principles of Biology	5
BIOL 162	Human Anatomy & Physiology OR	5
BIOL 320	Principles of Physiology OR	
BIOL 470	Plant Physiology	
BIOL 202	Principles of Plant Biology	5
BIOL 203	Principles of Animal Biology	5
BIOL 330	Ecology	5
BIOL 340	Genetics	5
BIOL 350	Microbiology	5
BIOL 432	Cell Biology	5
BIOL 485	Senior Project	4
BIOL XXX	Biology Elective	4-5
CHEM 141	General Chemistry 1	5
CHEM 142	General Chemistry 2	5
CHEM 143	General Chemistry 3	5
GEO 111	Rocks, Minerals, & Fossils	4
MATH 131	College Algebra or higher	4
MATH 150	Principles of Statistics OR	4
MATH 250	Statistics 1	
NTSC 110S	Scientific Reasoning & Methodology	4
PSCI 251	Physical Science by Inquiry 1	4

PHYSICAL SCIENCE (93 HOURS)

BIOL 151	Principles of Biology	5
CHEM 141	General Chemistry 1	5
CHEM 142	General Chemistry 2	5
CHEM 143	General Chemistry 3	5
CHEM 305	Organic Chemistry 1	4
CHEM 306	Organic Chemistry 2	4
CHEM 307	Organic Chemistry 3	4
CHEM 323	Quantitative Analysis	5
CHEM 485	Senior Project OR	4
PHYS 485	Senior Project	
GEO 111	Rocks, Minerals, & Fossils	4
MATH 201	Calculus 1	4
MATH 202	Calculus 2	4
MATH 250	Statistics 1	4

Course No.	Course	Cr. Hrs.
NTSC 110S	Scientific Reasoning & Methodology	4
PHYS 210	Astronomy	4
PHYS 211	Calculus-Based Physics 1	4
PHYS 212	Calculus-Based Physics 2	4
PHYS 213	Calculus-Based Physics 3	4
PHYS 214	Calculus-Based Physics 4	4
PHYS 300	Modern Physics	4
PSCI 251	Physical Science by Inquiry 1	4
PSCI 252	Physical Science by Inquiry 2	4

Adolescent to Young Adult (Grades 7-12) Licensure, Integrated Science in Conjunction with the Bachelor of Science in Natural Science

This program combines extensive work in a number of science areas with a license to teach all science areas in grades 7-12. Because of this, completion may take longer than a standard degree or program.

Degree Requirements

General Education Program (48 Hours)	36 Hours
<i>The Quantitative Reasoning and Natural Science components of the GEP are satisfied by the requirements of the bachelor of science in natural science. Further information is listed on page 55 of the current catalog or can be obtained from the Department of Teacher Education.</i>	
Integrated Science Component	122-126 Hours
Professional Education Core	20 Hours
<i>See page 111 of current catalog.</i>	
Reading Requirement	8 Hours
<i>See page 114.</i>	
Related Studies Component	12 Hours
<i>See page 114.</i>	
Adolescent/Young Adult Courses	32 Hours
<i>See page 115.</i>	
Total Hours Required	230-234 Hours

Integrated Science Component (122-126 Hours)

Course No.	Course	Cr. Hrs.
MATH 201	Calculus 1	4
MATH 202	Calculus 2	4
MATH 250	Statistics 1	4

Select one principal area of study from the following:

BIOLOGY (39 HOURS)

BIOL 151	Principles of Biology	5
BIOL 162	Human Anatomy & Physiology OR	5
BIOL 320	Principles of Physiology OR	
BIOL 470	Plant Physiology	
BIOL 202	Principles of Plant Biology OR	5
BIOL 203	Principles of Animal Biology	
BIOL 330	Ecology	5
BIOL 340	Genetics	5

BIOL 350	Microbiology	5
BIOL 432	Cell Biology	5
NTSC 110S	Scientific Reasoning & Methodology	4

CHEMISTRY (40 HOURS)

BIOL 411	Biochemistry	4
CHEM 141	General Chemistry 1	5
CHEM 142	General Chemistry 2	5
CHEM 143	General Chemistry 3	5
CHEM 305	Organic Chemistry 1	4
CHEM 306	Organic Chemistry 2	4
CHEM 307	Organic Chemistry 3	4
CHEM 323	Quantitative Analysis	5
NTSC 110S	Scientific Reasoning & Methodology	4

EARTH AND SPACE (37 HOURS)

BIOL 370	Marine Biology	5
GEOL 111	Rocks, Minerals, & Fossils	4
GEOL 112	Environmental Geology	4
GEOL 201	Physical Geology	4
GEOL 202	Historical Geology	4
GEOL XXX	Geology Elective	4
GEOG 227	Foundations of Meteorology	4
NTSC 110S	Scientific Reasoning & Methodology	4
PHYS 210	Astronomy	4

PHYSICS (36 HOURS)

NTSC 110S	Scientific Reasoning & Methodology	4
PHYS 210	Astronomy	4
PHYS 211	Calculus-Based Physics 1	4
PHYS 212	Calculus-Based Physics 2	4
PHYS 213	Calculus-Based Physics 3	4
PHYS 214	Calculus-Based Physics 4	4
PHYS 300	Modern Physics	4
PSCI 251	Physical Science by Inquiry 1	4
PSCI 252	Physical Science by Inquiry 2	4

Integrated science students must complete the three areas below not chosen as their principal area of study. Students may not duplicate their principal and subordinate areas of study. (Example: Students who choose biology as their principal area of study must take chemistry, earth and space, and physics as their subordinate areas of study.)

BIOLOGY AS SUBORDINATE AREA (25 HOURS)

BIOL 151	Principles of Biology	5
BIOL 162	Human Anatomy & Physiology OR	5
BIOL 320	Principles of Physiology OR	
BIOL 470	Plant Physiology	
BIOL 202	Principles of Plant Biology	5
BIOL 203	Principles of Animal Biology	5
BIOL 350	Microbiology	5

CHEMISTRY AS SUBORDINATE AREA (24 HOURS)

CHEM 141	General Chemistry 1	5
CHEM 142	General Chemistry 2	5
CHEM 143	General Chemistry 3	5
CHEM 200	Introduction to Organic Chemistry	4
CHEM 323	Quantitative Analysis	5

EARTH AND SPACE AS SUBORDINATE AREA (25 HOURS)

BIOL 370	Marine Biology	5
GEOL 111	Rocks, Minerals, & Fossils	4
GEOL 112	Environmental Geology	4

GEOL XXX	Geology Elective	4
GEOG 227	Foundations of Meteorology	4
PHYS 210	Astronomy	4

PHYSICS AS SUBORDINATE AREA (24 HOURS)

PHYS 211	Calculus-Based Physics 1	4
PHYS 212	Calculus-Based Physics 2	4
PHYS 213	Calculus-Based Physics 3	4
PHYS 214	Calculus-Based Physics 4	4
PHYS 300	Modern Physics	4
PSCI 251	Physical Science by Inquiry 1	4

Middle Childhood (Grades 4-9) Licensure, Mathematics and Science in Conjunction with the Bachelor of Science in Natural Science

Degree Requirements

General Education Program (48 Hours) 36 Hours

The Quantitative Reasoning and Natural Science components of the GEP (4 and 8 hours, respectively) are satisfied by the requirements of the bachelor of science in natural science. See page 55 for further information about the GEP.

Content Component 85-89 Hours

Professional Education Core 20 Hours
See page 111 of current catalog.

Reading Requirement 18 Hours
See page 111 of current catalog.

Middle Childhood (Math. & Science) 36 Hours

Related Studies Component 16 Hours

Minimum Hours Required 211-215 Hours

Content Component (85-89 Hours)**MATHEMATICS (44-45 HOURS)**

Course No.	Course	Cr. Hrs.
MATH 110S	Mathematics Core Course	4
MATH 140	Elementary Topics in Math. 1	4
MATH 141	Elementary Topics in Math. 2	4
MATH 300	History of Mathematics	4
MATH 305	Math. Enrichment for the Teacher	4
MATH 320	Foundations of Geometry	4
MATH 496	Senior Research Project 1	1
MATH 497	Senior Research Project 2	2
MATH 498	Senior Research Project 3	1

Select one pair of the following courses:

MATH 132	Precalculus 2	4
MATH 190	Brief Calculus with Applications	4

or

MATH 201	Calculus 1	4
MATH 202	Calculus 2	4

Select one of the following:

MATH 150	Principles of Statistics	4
MATH 250	Statistics 1	4

Select one of the following:

MATH 220	Discrete Mathematics	4
MATH 230	Linear Algebra	5

NATURAL SCIENCE (41-44 HOURS)

BIOL 151	Principles of Biology	5
CHEM 121	Introduction to General Chemistry 1	4
CHEM 122	Introduction to General Chemistry 2	4
GEOL 111	Rocks, Minerals, & Fossils	4
NTSC 110S	Scientific Reasoning & Methodology	4
PSCI 251	Physical Science by Inquiry 1	4
PSCI 252	Physical Science by Inquiry 2	4

Select three of the following:

BIOL 162	Human Anatomy & Physiology	5
BIOL 202	Principles of Plant Biology	5
BIOL 203	Principles of Animal Biology	5
BIOL 210	Taxonomy of Vascular Plants	4
BIOL 271	Field Ornithology	4
BIOL 272	Ohio's Natural Heritage	4
BIOL 302	Dendrology	4
BIOL 303	Spring Flora	4
BIOL 307	General Entomology	5
BIOL 370	Marine Biology	5
GEOL 112	Environmental Geology	4
GEOL 201	Physical Geology	4
GEOL 202	Historical Geology	4
GEOL 301	Invertebrate Paleobiology	4

**Middle Childhood (Mathematics and Science)
(36 Hours)**

EDMC 285	Practicum & Seminar 1: Observation & Reflection in Professional Practice	4
EDMC 385	Pract. & Sem. 2: Action Research - Home, School, & Comm. Relations	4
EDMC 470	Instructional Strategies & Mgt.	4
EDMC 473	Teaching Math. in Middle Grades	4
EDMC 476	Teach. Science in the Middle Grades	4
EDMC 485	Practicum & Seminar 3: Curric., Instruction, & Evaluation	4
EDMC 490	Directed Teaching & Seminar	12

Related Studies Component (16 Hours)

BUIS/ETCO	Computer Science Elective See page 81.	4
PSYC 101	Introduction to Psychology	4
PSYC 312	Adolescent Psychology	4
PSYC 375	Educational Psychology OR	4
PSYC 304	Psychology of Learning	

Multiage Visual Arts Licensure (PreK-12) in conjunction with the Bachelor of Fine Arts, Art Education

This program combines extensive work in a number of visual arts areas with a license to teach art in grades PreK-12. Because the program combines two areas, completion of the Visual Arts license may take longer than a standard degree or program.

Degree Requirements

General Education Program (48 Hours)	44 Hours
<i>The Non-Western Cultural Perspectives component of the GEP is satisfied by a requirement in the major. Further information is listed on page 55 of the current catalog or can be obtained from the Department of Teacher Education.</i>	
Art Core Requirements	44 Hours
Art Emphasis Area	32 Hours
Professional Education Core	20 Hours
<i>See page 111 of the current catalog.</i>	
Reading Requirement	4 Hours
Related Studies Component	12 Hours
Visual Arts Education Component	36 Hours
Art Studio Electives	24 Hours
Total Hours Required	216 Hours

Art Core Requirements (44 Hours)

Course No.	Course	Cr. Hrs.
ARTH 261	Art History Survey 1	4
ARTH 262	Art History Survey 2	4
ARTH 263	Art History Survey 3	4
ARTH XXX	Art History Electives (<i>Choose from ARTH 310, 331, 332, 360, 361, 364, or 366. Art education students are required to select ARTH 366 as one of their electives. This course also satisfies the Non-Western Cultural Perspectives component of the GEP and results in the waiving of 4 hours of the GEP requirement for art education students.</i>)	8
ARTS 101	Studio Foundations 1	4
ARTS 102	Studio Foundations 2	4
ARTS 103	Studio Foundations 3	4
ARTS 105	The Creative Process	4
ARTS 480	Senior Studio 1	4
ARTS 481	Senior Studio 2	4

Art Emphasis Area (32 Hours)

Choose 32 hours within either ceramics, drawing, or painting.

CERAMICS

ARTS 231	Ceramics 1	4
ARTS 232	Ceramics 2	4
ARTS 233	Ceramics 3	4
ARTS 331	Intermediate Ceramics 1	4
ARTS 332	Intermediate Ceramics 2	4
ARTS 333	Intermediate Ceramics 3	4
ARTS 334	Raku Ceramics	4
ARTS 335	Porcelain Ceramics	4
ARTS 336	Glaze Theory & Practice	4
ARTS 338	Mold Making	4
ARTS 434	Advanced Raku	4
ARTS 435	Advanced Porcelain	4
ARTS 436	Advanced Glaze Theory & Practice	4

DRAWING

ARTS 271	Life Drawing 1	4
ARTS 272	Life Drawing 2	4
ARTS 273	Life Drawing 3	4

ARTS 275	Drawing 1	4
ARTS 276	Drawing 2	4
ARTS 371	Intermediate Life Drawing 1	4
ARTS 372	Intermediate Life Drawing 2	4
ARTS 373	Intermediate Life Drawing 3	4
ARTS 375	Intermediate Drawing 1	4
ARTS 376	Intermediate Drawing 2	4
ARTS 475	Advanced Drawing 1	4
ARTS 476	Advanced Drawing 2	4

PAINTING

ARTS 221	Painting 1	4
ARTS 222	Painting 2	4
ARTS 223	Painting 3	4
ARTS 321	Intermediate Painting 1	4
ARTS 322	Intermediate Painting 2	4
ARTS 323	Intermediate Painting 3	4
ARTS 324	Watercolor 1	4
ARTS 325	Watercolor 2	4
ARTS 326	Watercolor 3	4
ARTS 327	Figure Painting 1	4
ARTS 328	Figure Painting 2	4
ARTS 329	Figure Painting 3	4
ARTS 421	Advanced Painting 1	4
ARTS 422	Advanced Painting 2	4
ARTS 423	Advanced Painting 3	4
ARTS 424	Advanced Watercolor 1	4
ARTS 425	Advanced Watercolor 2	4
ARTS 426	Advanced Watercolor 3	4
ARTS 427	Advanced Figure Painting 1	4
ARTS 428	Advanced Figure Painting 2	4
ARTS 429	Advanced Figure Painting 3	4

Reading Requirement (4 Hours)

EDRE 305	Teaching Reading in the Content Areas	4
----------	---------------------------------------	---

Art Studio Electives (24 Hours)

Choose at least one course from each area outside studio emphasis.

CERAMICS (4 HOURS)

ARTS 231	Ceramics 1	4
ARTS 232	Ceramics 2	4
ARTS 233	Ceramics 3	4

COMPUTER ART (4 HOURS)

ARTS 106	Digital Foundations	4
ARTS 362	Digital Imaging 2	4
ARTS 363	Digital Illustration/Type 2	4
ARTS 364	Digital Paint 2	4

DRAWING (4 HOURS)

ARTS 271	Life Drawing 1	4
ARTS 272	Life Drawing 2	4
ARTS 273	Life Drawing 3	4
ARTS 275	Drawing 1	4
ARTS 276	Drawing 2	4
ARTS 277	Drawing 3	4

PAINTING (4 HOURS)

ARTS 221	Painting 1	4
ARTS 222	Painting 2	4

ARTS 223	Painting 3	4
ARTS 324	Watercolor 1	4
ARTS 325	Watercolor 2	4

PHOTOGRAPHY (4 HOURS)

ARTS 210	Photography 1	4
ARTS 211	Photography 2	4
ARTS 212	Photography 3	4

PRINTMAKING (4 HOURS)

ARTS 244	Introduction to Printmaking	4
ARTS 245	Intaglio	4
ARTS 246	Lithography	4
ARTS 247	Screen Printing	4
ARTS 248	Relief Printing	4

SCULPTURE (4 HOURS)

ARTS 241	Sculpture 1	4
ARTS 242	Sculpture 2	4
ARTS 243	Sculpture 3	4

Related Studies Component (12 Hours)

PSYC 101	Introduction to Psychology	4
PSYC 151	Human Growth & Development	4
PSYC 304	Psychology of Learning OR	4
PSYC 375	Educational Psychology	4

Visual Arts Education Component (36 Hours)

ARTP 401	Studio Methods for Early Childhood	4
ARTP 402	Studio Methods for Middle Child.	4
ARTP 403	Studio Methods for Adolescents	4
EDVA 285	Pract. & Sem. 1: Observation & Reflection in Professional Practice	4
EDVA 385	Pract.& Sem. 2: Action Research - Home, School, & Comm. Relations	4
EDVA 485	Practicum & Seminar 3: Curric., Instruction, & Evaluation	4
EDVA 490	Directed Teaching & Seminar	12

Associate of Applied Science in Early Childhood Development with Pre-Kindergarten Associate Licensure

Degree Requirements

General Education Courses	24 Hours
<i>ENGL 111S, 112S, and 115S, MATH 110S, NTSC 110S, and SOCI 101 are required.</i>	
Professional Education Core	12 Hours
Related Studies Component	8 Hours
Early Childhood Courses	24 Hours
Curriculum Content	10 Hours
Pre-K Associate Licensure Content	20 Hours
Total Hours Required	98 Hours

Professional Education Core (12 Hours)

Course No.	Course	Cr. Hrs.
EDUC 115	Intro. to the Teaching Profession	4
EDUC 230	Instructional Media, Technology, & Computers	4
EDUC 245	Teaching Individuals in a Pluralistic Society	4

Related Studies Component (8 Hours)

PSYC 101	Introduction to Psychology	4
PSYC 151	Human Growth & Development	4

Early Childhood Courses (24 Hours)

EDEC 150	Intro. to Early Childhood Education	4
EDEC 255	Educational Environments	4
EDEC 280	Administration of Early Childhood Programs	4
EDEC 283	Interprofessional and Parental Team Models	4
EDEC 284	Basic Movement for Children	4
EDEC 285	Practicum/Seminar 1: Observation & Reflection in Professional Practice	4

Curriculum Content (10 Hours)

ARTP 201	Art in the Curriculum	3
MUSI 160	Fundamentals of Music	3
SSAT 227	First Aid	4

Students who already have first aid/CPR training (evidence required) must take 4 additional hours. EDIS 250 and/or EDUC 240 are strongly suggested.

Pre-K Associate Licensure Content (20 Hours)

EDPA 286	Aesthetics: Movement, Art, Music Dramatic Play	3
EDPA 287	Symbolics: Language, Literacy, Reading, Mathematics	3
EDPA 288	Empirics: Health, Nutrition, Science, & Social Studies	3
EDPA 289	Instructional Methods Practicum 1	1
EDPA 289	Instructional Methods Practicum 2	1
EDPA 289	Instructional Methods Practicum 3	1
EDPA 290	Directed Teaching & Seminar	8

Reading Education Program

The reading education program provides a series of specially designed courses and field experiences leading to a reading endorsement in the **specific licensure/certificated area**. This program is designed for both preservice students and in-service teachers. In-service teachers applying for reading endorsement need to be assigned a reading advisor prior to admission into the program. EDRE 406, 407, and 485 must be taken at Shawnee State in

order for the Department of Teacher Education to recommend a student to ODE for reading endorsement.

Reading Endorsement Requirements

Course No.	Course	Cr. Hrs.
EDRE 304	Teaching Phonics: Reading, Writing, & Spelling	5
EDRE 305	Teaching Reading in the Content Areas	4
EDRE 406	Reading Diagnosis & Assessment	5
EDRE 407	Strategies in Reading Instruction	4
EDRE 485	Practicum in Reading	3-6
ENGL 300	Children's Literature <i>OR</i>	4
ENGL 323	Adolescent Literature	

Note: Students must take and pass the Praxis II Introduction to the Teaching of Reading Exam and successfully complete a Reading Portfolio based on IRA/NCATE standards and the five DTE competency domains.

Bachelor of Science in Sports Studies

The bachelor of science in sports studies offered by the Department of Teacher Education prepares you for a career in an employment area that addresses the health and physical fitness needs of people in our society. Our curriculum ranges from in-depth study of the levels of sports participation to injury prevention and treatment to sports management in general. The program also provides the real work situations, hands-on training, and strong theoretical base from which you can make a career decision.

Graduates of the athletic training program will find employment opportunities in such areas as colleges and universities, professional sports organizations, hospitals, sports medicine clinics, and the fitness industry. Graduates may also elect to pursue graduate study in athletic training, exercise physiology, or other allied health areas. Employment opportunities for sports management graduates may include college and professional teams, health clubs, recreation departments, sport facilities, sporting goods manufacturers and dealers, and a variety of sports marketing-related firms. Internships and graduate study are strongly encouraged as they can provide contacts which may prove essential to securing a position in the highly competitive sports industry.

Application for Admission to the Sports Studies Degree Programs (Athletic Training/Sports Management)

You must apply for and receive acceptance into the sports studies degree programs before you are eligible to take 300 and 400 level courses.

Applications are available from the Department of Teacher Education, located in Massie Hall, room 227. Once completed, applications should be returned to the Department of Teacher Education for review by the admissions committee, which meets to review applications on an as-needed basis.

Students are evaluated according to the following minimum admission requirements.

- You must have an overall GPA of 2.0 or higher.
- All of the following courses must be completed with a grade of C or higher:

ENGL 111S	MATH 110S
ENGL 112S	SPCH 103
ENGL 115S	SSPE 202
- You must have satisfactorily completed five observation hours prior to application.

Bachelor of Science in Sports Studies with a Concentration in Athletic Training

The athletic training concentration provides students with the knowledge and understanding of the athletic training profession. Graduates of the program are able to implement prevention-of-injury programs and provide immediate treatment and rehabilitation procedures for injured athletes. They have a thorough knowledge of anatomy, physiology, hygiene, kinesiology, nutrition, taping, conditioning, prevention of injury methodology, protective equipment, first aid, and emergency care.

Our graduates also possess the human relations and communication skills necessary to work well with team physicians, coaches, administrators, and athletes.

The athletic training program utilizes classroom instruction and structured practical (clinical) experiences to allow the students to gain knowledge and skills needed to fulfill requirements to be eligible to sit for the National Athletic Trainers' Association Board of Certification (NATABOC) examination upon graduation from SSU.

Special Note: Students are not automatically certified after the completion of the athletic training

program. You must successfully take and pass the National Athletic Trainers Association Board of Certification (NATABOC) examination. As of January 2004, all applicants who wish to sit for the NATABOC examination must graduate from an accredited athletic training education program (accredited from the Commission on Accreditation of Allied Health Education Programs CAAHEP). SSU is currently actively seeking candidacy for accreditation. Even though a school is seeking or is in candidacy does NOT guarantee the program will become accredited.

Application for Admission to the Athletic Training Program

Admission into the athletic training program at Shawnee State University is selective and limited. The number of students accepted into the program each year is based on the availability of clinical supervisors and quality clinical instruction. Students must meet the following eligibility requirements for formal admission into the athletic training program:

- Cumulative GPA of 2.5 or higher.
- Submission of a written application, including three character references.
- Successful completion of 100 directed clinical observation hours.
- Successful completion of an interview with the Athletic Training Selection Committee.
- Current CPR certification.
- Completion of the following prerequisite coursework with a grade of C or better:

AHNR 102 Medical Terminology (2)
 BIOL 151 Principles of Biology (5)
 SSAT 220 Introduction to Athletic Training (3)
 SSAT 222 Athletic Training Laboratory (2)
 SSAT 227 First Aid (4)

- Attendance and successful completion of a universal precautions in-service and proof of HVB vaccination (or initiation of the series) or sign a form of declination of the vaccine.

Note: Transfer students and sophomores who have met the above criteria are welcome to apply.

Degree Requirements

General Education Program (48 hours) 40 Hours
The Natural Science component of the GEP is satisfied by requirements in the major. Further

information is listed on page 55 of the current catalog or can be obtained from the Department of Teacher Education.

Athletic Training Concentration	114 Hours
University Electives	32 Hours
Total Hours Required	186 Hours

Athletic Training Concentration (114 Hours)

Course No.	Course	Cr. Hrs.
AHNR 102	Medical Terminology	2
BIOL 130	Prin. of Anatomy & Physiology 1	5
BIOL 131	Prin. of Anatomy & Physiology 2	5
BIOL 311	Kinesiology	4
BIOL 320	Principles of Physiology	5
PSYC 101	Introduction to Psychology	4
SPCH 103	Public Speaking & Human Comm.	3
SSAT 220	Introduction to Athletic Training	3
SSAT 222	Taping & Strapping Laboratory	2
SSAT 227	First Aid/CPR	4
SSAT 310	Athlete Health Maintenance	4
SSAT 320	Preven. & Assess./Upper Body	4
SSAT 322	Preven. & Assess./Lower Body	4
SSAT 324	Preven. & Assess./Head, Neck	4
SSAT 325	Rehabilitation of Athletic Injury	4
SSAT 326	Therapeutic Modalities	4
SSAT 396	Practicum 1 in Athletic Training	3
SSAT 397	Practicum 2 in Athletic Training	3
SSAT 398	Practicum 3 in Athletic Training	3
SSAT 420	Physiology of Exercise	4
SSAT 422	Prevention and Assessment of Non-Orthopedic Injuries	4
SSAT 428	Athletic Training Administration	4
SSAT 496	Practicum 4 in Athletic Training	3
SSAT 497	Practicum 5 in Athletic Training	3
SSAT 498	Practicum 6 in Athletic Training	3
SSPE 202	Health & Nutri. Across the Lifespan	4
SSPE 203	Human Nutrition	4
SSPE 495	Special Topics	4
SSSM 228	Law & Liability in Sports	4
SSSM 370	Ethical Aspects of Sport	3
SSSM 385	Psychology of Sport	4

Bachelor of Science in Sports Studies with a Concentration in Fitness Development

The fitness development program at Shawnee State is designed to prepare individuals for careers in fitness and health promotion, strength and conditioning, and wellness programs.

Students in the program learn how to assess and evaluate fitness levels for individuals and groups and design, implement, manage, and evaluate fitness programs. All students complete a mandatory three-month internship in a local health/fitness facility.

Graduates of the program find employment opportunities in both public and private health

and fitness facilities and in worksite and health care settings. The program also provides appropriate preparation for individuals desiring to pursue graduate study in fitness, health, and exercise science programs.

Degree Requirements

General Education Program (48 hours)	40 Hours
<i>The Natural Science component of the GEP is satisfied by requirements in the major. Further information is listed on page 55 of the current catalog or can be obtained from the Department of Teacher Education.</i>	
Fitness Development Concentration	97 Hours
University Electives	50 Hours
Total Hours Required	187 Hours

Fitness Development (97 Hours)

Course No.	Course	Cr. Hrs.
AHNR 102	Medical Terminology	2
BIOL 151	Principles of Biology	5
BIOL 162	Human Anatomy & Phys. OR	5
BIOL 310	Principles of Anatomy	
BIOL 311	Kinesiology	4
BIOL 320	Principles of Physiology	5
BUMG 225	Organization of Small Business	4
PHIL 340	Philosophy of Sport	4
PSYC 101	Introduction to Psychology	4
SPCH 103	Public Speaking & Human Comm.	3
SSAT 227	First Aid/CPR	4
SSAT 310	Athlete Health Maintenance	4
SSAT 420	Physiology of Exercise	4
SSFD 261	Principles of Personal Fitness	2
SSFD 440	Exercise Prescription	4
SSFD 450	Exercise Testing & Measurements	4
SSFD 490	Internship in Fitness Training	12
SSPE 202	Health & Nutri. Across the Lifespan	4
SSPE 203	Human Nutrition	4
SSPE 495	Special Topics	4
SSSM 228	Law & Liability in Sports	4
SSSM 370	Ethical Aspects of Sport	3
SSSM 385	Psychology of Sport	4
SSSM 450	Org./Admin. of Sport Prog.	4

Bachelor of Science in Sports Studies with a Concentration in Sports Management

This degree prepares you for employment in a corporate fitness center, health club, nautilus center, or sports organization/federation.

Students enrolled in the sports management concentration focus on business skills such as financial management, marketing, and the legal questions associated with sports and exercise. They also examine the relationship of play, game sports,

athletics, and fitness to our culture. This concentration's curriculum provides a foundation of sports management philosophy, principles, and objectives. Field experiences are also a part of the program and provide practical experience in various sports settings.

Degree Requirements

General Education Program	48 Hours
<i>Further information is listed on page 55 of the current catalog or can be obtained from the Department of Teacher Education.</i>	
Sports Management Concentration	105 Hours
University Electives	33 Hours
Total Hours Required	186 Hours

Sports Management Concentration (105 Hours)

Course No.	Course	Cr. Hrs.
BUAC 101	Accounting 1	4
BUAC 102	Accounting 2	4
BUAI 101	Computer Applications 1	4
BUFI 245	Principles of Finance	4
BULW 270	Legal Environment of Business	4
BUMG 235	Personnel Management	4
BUMG 305	Prof. Communication & Dev. Skills	4
BUMG 310	Management Principles	4
BUMK 310	Marketing Principles	4
ECON 201	Microeconomics	4
ETCO 150	HTML Programming/Web Page Design OR	4
BUAI 150	Internet & Web Publishing	
JOUR 105	Intro. to Mass Communication	4
JOUR 231	News Reporting	4
PHIL 340	Philosophy of Sport	4
SPCH 103	Public Speaking & Human Comm.	3
SSAT 310	Athlete Health Maintenance	4
SSSM 201	Introduction to Sports Management	3
SSSM 235	Orient. To Sport Ind. Employment	2
SSSM 368	Introduction to Sport Law	4
SSSM 370	Ethical Aspects of Sport	3
SSSM 385	Psychology of Sport	4
SSSM 386	Sociology of Sport	4
SSSM 390	Sport Facility & Event Management	4
SSSM 392	Sport Marketing	4
SSSM 407	Practicum 1	4
SSSM 408	Practicum 2	6
SSSM 450	Org./Admin. of Sport Prog.	4

Minor

Sport Coaching

The minor in sport coaching program at Shawnee State University is designed to prepare students for coaching positions at the high school and college levels. The program provides students with a foundation in sport coaching, as well as a

background in the legal, ethical, psychological, medical, and administrative aspects of the coaching profession.

As Shawnee State does not offer a major in physical education, students desiring to coach at the high school level are advised to major in teacher education and pursue state licensure in a content area within secondary education.

Those students wishing to pursue a career in coaching at the college level are encouraged to consult with the coordinator of sports studies regarding appropriate undergraduate majors. Such students should also plan to attend graduate school.

Required Courses

Course No.	Course	Cr. Hrs.
SSAT 227	First Aid/CPR	4
SSAT 222	Taping and Strapping	3
SSAT 310	Athlete Health Maintenance	4
SSSM 228	Law & Liability in Sports	4
SSSM 385	Psychology of Sport	4
SSPE 245	Foundations of Coaching	4
SSPE XXX	Coaching of (<i>choose one</i>):	2
SSPE 340	Volleyball	
SSPE 341	Basketball	
SSPE 342	Football	
SSPE 343	Track	
SSPE 344	Softball	
SSSM 370	Ethical Aspects of Sport	3
SSSM 407	Practicum 1	4
Total Hours Required:		32

Practicum Experience

All students enrolled in the minor in sport coaching complete a practicum experience under the direction of either a Shawnee State or local high school head coach in the sport of the student's choice. Students may indicate a preference for a given practicum site; however, the assignment will ultimately be made by the practicum director.

The length of each practicum experience corresponds to the length of the sport season. Students are advised that some sport seasons may involve work in more than one academic quarter during the year. Students must provide their own transportation to practicum sites.

Certificates

Deaf Studies

Students enrolled in the one-year deaf studies program acquire a certificate that enhances opportunities for any career that interacts with the

public and persons with deafness or hearing loss. Through their studies, students acquire knowledge of deafness, an overview of the deaf community and its culture, and American Sign Language (ASL) vocabulary. Career opportunities within the field of deafness include: audiologist, counselor, dormitory/residence program counselor, interpreter, linguist, social worker, speech-language pathologist, teacher, parent/infant specialist, health care providers, and combined specialties.

Requirements (45 Hours)

Prerequisite: SIGN 101 Introduction to Sign Language (Students may test out of this course.)

QUARTER 1 (FALL)

BUIS 101	Intro. to Computer Information Systems
ENGL 111S	Discourse and Composition
SIGN 102	American Sign Language 1

QUARTER 2 (WINTER)

ENGL 112S	Composition and Research
PSYC 101	Introduction to Psychology
SIGN 103	American Sign Language 2
SIGN 108	Fingerspelling
SIGN 201	Orientation to Deafness

QUARTER 3 (SPRING)

SIGN 104	American Sign Language 3
SIGN 202	Psychology of Hearing Impaired
SOCI 101	Introduction to Sociology
SPCH 103	Public Speaking and Human Communication



COLLEGE OF
PROFESSIONAL
STUDIES

College of Professional Studies

The mission of the College of Professional Studies is to prepare you for a meaningful career in business, engineering technologies, or health sciences. We are also committed to providing the practical and theoretical background that enables your success in advanced educational programs.

Courses taught in professional studies combine hands-on learning experiences, based on guided professional practice. Many courses are conducted in on-campus laboratories that simulate the career or industrial settings in which you will work after graduation. Others, especially in the health sciences, are taught in off-campus, clinical settings, where you experience interactions with clients first hand.

Students in professional studies also take courses offered by the College of Arts and Sciences. Many of these are career oriented, while some—especially in the General Education Program—are required of all university graduates.

For More Information

Martha C. Rader, Ph.D., Dean

Ann C. McCarthy, Secretary

College of Professional Studies

Shawnee State University

940 Second Street

Portsmouth, Ohio 45662-4344

Phone: 740.351.3270

Fax: 740.351.3354

E-mail: amccarthy@shawnee.edu

Programs Offered

Bachelor of Individualized Studies

See page 128 of current catalog for description.

Bachelor of Science

Business Administration, Accounting

Business Administration, General

Business Administration, Health Management

Business Administration, Legal Assisting (2+2)

Business Administration, Management
Information Systems

Computer Engineering Technology

Environmental Engineering Technology

Nursing (RN-BSN)

Occupational Therapy (*To be discontinued.*)

Plastics Engineering Technology

Minors

Business Administration

Computer Aided Design

Health Management

Plastics Engineering Technology

Associate of Applied Business

Accounting Technology

Business Information Systems

Business Management Technology

Legal Assisting Technology

Office Administration Technology

Associate of Applied Science

Associate Degree Nursing

Computer Aided Design

Dental Hygiene

Electromechanical Engineering Technology

Emergency Medical Technology

Medical Laboratory Technology

Occupational Therapy Assistant

Physical Therapist Assistant

Plastics Engineering Technology

Radiologic (X-ray) Technology

Respiratory Therapy

Associate of Individualized Studies

See page 129 of current catalog for description.

Certificates

Computer Aided Drafting and Design

Plastics Engineering Technology

Web Engineering Technology

Reputation for Excellence

Employers of our graduates consistently give high marks and excellent reviews to Shawnee State's professional studies programs, and many of our students are now successfully pursuing graduate level work or have entered professional schools. Our students' performances on national and licensure exams are excellent; well above national averages. The College of Professional Studies jealously protects and continues to enhance this reputation for excellence.

Faculty

Faculty in professional studies are experienced and academically credentialed or certified by appropriate professional associations in their career fields. Moreover, our faculty are committed to your success in the college classroom and in your career beyond Shawnee State University.

Commitment to the Future

In addition to the degree programs listed on the previous page, the College of Professional Studies is currently seeking approval for other academic programs that address the educational needs of students and the employment needs of business, industry, and health care. Just as we survey employers to determine employment needs for the future, we also ask you to inform us of your educational and occupational goals so that we can become an active partner in the pursuit of those goals.

If the College of Professional Studies does not currently offer a degree that meets your needs, you may design, with the help of your academic advisor, an associate's or bachelor's of individualized studies degree which includes two or more subject areas of interest to you.

We are proud of our graduates' success. Your participation and ideas contribute to our tradition of excellence.

Bachelor of Individualized Studies Degree (B.I.S.)

The bachelor of individualized studies is administered by the College of Arts and Sciences and the College of Professional Studies as appropriate. Students interested in a B.I.S. program should contact the dean of the college most closely associated with their field of study/interest.

The B.I.S. is intended for undergraduate students who wish to pursue an area of study (or combination of areas) which is not available in other academic programs at Shawnee State. The proposed course of study must not closely parallel programs already offered at the university. The desire to avoid certain specific requirements of existing majors or degree programs is not a sufficient justification for choosing a B.I.S. program.

This degree may be particularly useful to working students taking evening, weekend, or off-campus classes. Also, the B.I.S. may be used to combine the coursework from an associate degree program

with an area of concentration from another field of study. For example, students completing an associate degree in one of the health sciences programs may elect to include an area of concentration in health management or business administration for a B.I.S. degree.

Students planning to pursue graduate or professional school degrees are advised to complete a traditional major at the undergraduate level rather than complete the B.I.S. degree.

Admission to the Bachelor of Individualized Studies

After admission to the University, a student makes an appointment for a conference with an individualized studies advisor. The student makes this appointment by contacting either the dean of the College of Arts and Sciences or the dean of the College of Professional Studies.

In this conference, the advisor will explore with the student the appropriateness of the bachelor of individualized study given his or her background and academic goals.

To obtain formal admission to the bachelor of individualized studies, the student must complete an application, which includes the following elements:

- A statement explaining that the student understands the nature and intent of the general studies major
- A statement of plans for future education and employment with the individualized studies major as a foundation
- A statement of the goals the proposed course of study will meet, an appropriately detailed outline of the proposed course of study, and a projected graduation date

The application for admission to the bachelor of individualized study will be reviewed by a three-person faculty advisory committee consisting of the student's faculty advisor and two faculty appointed by the appropriate college's dean. If the application and proposed course of study is approved by the advisory committee, these items will be forwarded to the appropriate dean for approval and the registration of these degree requirements by the registrar.

Advising

The student pursuing an individualized studies major is encouraged to seek academic advising each quarter.

Degree Requirements

The individualized studies major must meet and fulfill university requirements for baccalaureate programs and those requirements specific to this degree. These include:

- A minimum of 186 credit hours, including the General Education Program.
- A minimum of 2.00 cumulative grade point average for all courses taken at Shawnee State University.
- Completion of at least 45 credit hours of upper-division level (300–400 courses), no more than 10 hours of which may be transferred in from another accredited university or college.
- A minimum of 45 credit hours completed at Shawnee State. The University's general policies regarding the transferability of courses from other colleges and universities will apply equally to this major.
- A minimum of 60 credit hours in the individualized/specialized area of study and cognate areas, as approved by a three- faculty committee.
- Completion of the specific program of study initially approved by the student's faculty advisory committee upon admission to the major. Any subsequent alterations in the program, including course substitutions, must receive the approval of the student's advisory committee.
- The completion of at least 45 credit hours after approval of student's program.
- Petition for graduation in accordance with the rule prescribed by the University.

Associate of Individualized Studies Degree (A.I.S.)

The associate of individualized studies degree (AIS) at Shawnee State University allows you to formulate your own individualized program of study based upon specific criteria. The goal of this degree is to permit the student, under the guidance of faculty advisors, to combine selected courses in academic and/or technical areas that may not meet the degree requirements for Shawnee State's associate of arts, associate of science, associate of applied science, or associate of applied business degrees.

The following conditions must be met for completion of the degree: 1) a total of 90 credit hours of 100-level or above coursework with a

minimum grade point average of 2.00; 2) a minimum of two areas of concentration with at least 20 credit hours in each; 3) a set of minimum general education requirements as outlined below; and 4) completion of a minimum of 45 hours of credit after admission to the program.

The minimum set of general education requirements for the AIS is as follows:

- ENGL 111S and ENGL 112S (8 hours)
- One course at or above MATH 105 (4 hours)
- At least 12 hours from three different categories of the Foundational Level of the University's General Education Program, described on pp. 55-57. The Foundational Level includes the following categories: social sciences, natural sciences, English composition (ENGL 115S), and fine and performing arts.

Note: If you plan to transfer to another state university in Ohio in order to pursue a four-year degree program, you should consider completing the general education transfer module as outlined on page 19 of this catalog.

For specific details and application forms for the program, contact the dean's office in the College of Arts and Sciences or the dean's office in the College of Professional Studies.



BUSINESS

ADMINISTRATION



Business Administration

The Department of Business Administration provides the opportunity, resources, and experiences necessary for students to acquire the business knowledge and skills to be personally and professionally successful.

The Department seeks to develop in students a continuing intellectual curiosity, an awareness of individual and cultural diversity, and a high degree of professional competence. The Department encourages an integrated general education in the arts and sciences, provides a body of knowledge common to all areas of business, and provides a systematic body of specialized knowledge and skills applicable to specific business disciplines.

To meet the diverse needs of students and businesses, the Department offers programs at the associate level, stressing applied entry-level skills, and at the baccalaureate level, stressing the broader theoretical concepts and leadership skills applicable to more complex organizational problems.

For More Information

Chairperson or
Judy Nolfi, Secretary
Department of Business Administration
Shawnee State University
940 Second Street
Portsmouth, Ohio 45662-4344
Phone: 740.351.3215
Fax: 740.351.3663
E-mail: jnolfi@shawnee.edu

Programs in Business

Bachelor of Individualized Studies

See page 128 of current catalog for description.

Bachelor of Science

Business Administration, Accounting
Business Administration, General
Business Administration, Health Management
Business Administration, Legal Assisting (2+2)
Business Administration, Management
Information Systems

Minor

Business Administration
Health Management

Associate of Applied Business

Accounting Technology
Business Information Systems
Business Management Technology
Legal Assisting Technology
Office Administration Technology

Associate of Individualized Studies

See page 129 of current catalog for description.

Bachelor Degrees

Special Notes for all Bachelor Degrees in Business Administration

Please read carefully. Consult your advisor if you do not fully understand.

- **Quantitative Reasoning Requirement, General Education Program** If you select MATH 150 or MATH 170 to fulfill your quantitative reasoning requirement in the General Education Program, you must meet the minimum degree requirement of 188 total credit hours.
- **Calculus** Most graduate programs in business require calculus as a prerequisite. **Students considering a future masters degree in business should take MATH 190 as one of their elective courses.**
- **Nonbusiness Electives** Two hours of non-business courses may be in physical education (HPER).
- **Mathematics/English Sequence** Placement in beginning English and mathematics courses is determined by the mathematics and English placement tests. The minimum mathematics course in the business core is MATH 170. Any nondevelopmental mathematics courses (101 or higher) taken to meet the prerequisite for MATH 170 may be credited as nonbusiness electives toward the BSBA degree.
- **Transfer Credit** A minimum of 24 hours of the business core must be completed at Shawnee State University. Sixteen hours of upper division elective courses required for the general business concentration must be completed at Shawnee State.
- **Special Topics in Business Courses (299, 399, and 499)** A formal review and a subsequent

written approval by the business department review committee is mandatory before credit is given for any special topics course. This review committee is made up of one member from each of the instructional areas, and this approval applies to all students. You can accumulate a total of 12 credit hours in the business department using special topics courses. These courses apply for credit toward electives only and not toward required courses or the 16 hours of upper division business electives. Faculty members are not required to teach a special topics course; classes and subject matter are at the faculty member's option.

- **Upper-Level/Lower-Level Course Credit** Any student having earned credit for an upper-level course cannot subsequently earn credit for a lower sequence course and apply it toward graduation. Example: If you earned credit for BUMG 310, you could not later take the lower-level course BUMG 210 and apply the credits toward graduation. This notice applies, but is not limited to, BUFI 245, 250, BUMG 101, 210, 235, and BUMK 210.

Bachelor of Science in Business Administration with a Concentration in Accounting

The four-year program in general business with a concentration in accounting is designed to provide students with a broad understanding of the field. A broad-based general education precedes an extensive education in accounting, providing the successful graduate with the necessary tools for a career in accounting or graduate studies.

The accounting program has a core of accounting and nonaccounting courses. Students choose—in consultation with their advisors—at least 16 hours of electives. This allows some flexibility to design a program which meets career goals.

Careers in Accounting

Careers in accounting span the entire spectrum of human activity. Accountants are employed in private industry, small businesses, hospitals, government agencies and subdivisions, social organizations, and many other areas. Some accountants provide service to the public on a fee basis as professionals.

The Accounting Technician

Many clerical accounting positions exist within various types of organizations. The positions may involve billings and collections, cash control, data inputting to computerized accounting systems, payables management, and payroll and personnel records administration. The minimum requirement for entry into one of these positions is usually an associate degree in accounting or related experience. You may wish to seek an associate degree in accounting to begin your career and later pursue an advanced degree to further your career objectives (see page 137).

The Internal Accountant

All complex organizations need the expertise of accountants, who are responsible for providing information to management for decision making purposes; ensuring compliance with federal, state, and local laws (including tax reporting); and evaluating the financial effects of management's decisions. These functions become highly specialized in the large complex corporate environment. Many accountants also work for federal government agencies such as the Internal Revenue Service or the General Accounting Office. Others work in state and local government agencies. Accountants are employed in highly responsible positions in schools, hospitals, and medium-sized businesses. Many individuals have advanced to positions of chief financial officer (CFO) or chief executive officer (CEO) of large organizations. The minimum requirement to obtain employment as an internal accountant is generally a bachelor's degree with a concentration in accounting.

Professional Certification

Professional certification has generally been recognized as the ultimate achievement in the accounting profession. Certification is achieved by passing a comprehensive national examination. The Certified Public Accountant (CPA) is the most widely known professional certification, but certification is also available in management accounting (CMA) and internal auditing (CIA). The CPA is licensed by a state authority to practice public accounting, which means to provide accounting services to businesses or private citizens according to established, set standards. To qualify for the designation of certified public accountant, an individual must complete a program of study

in accounting at a college or university, must pass the comprehensive two-day Uniform CPA Examination, and meet experience requirements established by the state. Candidates sitting for the CPA Examination in Ohio must complete 150 semester (225 quarter) hours of college education or must successfully complete preliminary “qualifying” examinations. (See an accounting advisor for additional details.)

The certified management accountant and certified internal auditor designations indicate expertise in areas of internal accounting.

The Program at Shawnee State

The curriculum at Shawnee State University is designed to provide the maximum flexibility in achieving your educational and career objectives, recognizing that they may change during your period of study. You may obtain an associate’s degree and employment as an “accounting technician” while you continue study toward a baccalaureate degree with a concentration in accounting. Those students who wish to sit for the Uniform CPA Examination need to work closely with an accounting advisor in order to achieve the 150 semester (225 quarter) hour requirement. Some students may wish to achieve this objective by completing the concentration in accounting at Shawnee State and pursuing postbaccalaureate study at another institution. The curriculum at SSU is designed so that all hours are fully compatible to all educational objectives. (An articulation worksheet is available.)

Degree Requirements

General Education Program (48 Hours)	44 Hours
<i>MATH 170, required in all BSBA concentrations, satisfies the Quantitative Reasoning component of the GEP. Students pursuing a concentration in accounting must complete PHIL 320 which also fulfills the Ethics requirement in the GEP. Further information about the GEP is listed on page 55 of the current catalog or can be obtained from the dean’s office.</i>	
Other General Ed. Requirements	16 Hours
Electives	28 Hours
Business Admin. Requirements	68 Hours
Accounting Concentration Req.	28 Hours
Upper Level Accounting Electives	12 Hours
Total Hours Required	196 Hours

Other General Education Requirements (16 Hours)

Course No.	Course	Cr. Hrs.
ECON 201	Principles of Microeconomics	4
ECON 202	Principles of Macroeconomics	4
MATH 150	Principles of Statistics	4
MATH 170	Applied Finite Mathematics	4

Electives (28 Hours)

It is recommended that you consult your advisor regularly in choosing electives. Students planning to pursue postgraduate studies should include MATH 190 as an elective.

Accounting Concentration Requirements (28 Hours)

BUAC 215	Tax Accounting	4
BUAC 221	Cost Accounting	4
BUAC 231	Intermediate Accounting 1	4
BUAC 322	Advanced Cost Concepts	4
BUAC 332	Intermediate Accounting 2	4
BUAC 333	Intermediate Accounting 3	4
BUAC 431	Advanced Accounting 1 OR	4
BUAC 339	Special Problems in Financial Acct.	

Upper Level Accounting Electives² (12 Hours)

Select three:

BUAC 305	Governmental Accounting	4
BUAC 330	Industrial Accounting	4
BUAC 360	Systems Accounting	4
BUAC 410	Health Care Accounting	4
BUAC 431	Advanced Accounting 1	4
BUAC 433	Advanced Accounting 2	4
BUAC 435	Auditing/Ethics	4

Business Administration Requirements (68 Hours)

BUAC 101 ¹	Accounting 1	4
BUAC 102 ¹	Accounting 2	4
BUAC 103 ¹	Accounting 3	4
BUAI 101 ¹	Computer Applications 1	4
BUAI 102 ¹	Computer Applications 2	4
BUAI/BUIS ²	Elective (or BUOA 215)	4
BUFI 345	Managerial Finance	4
BUFI XXX ²	Elective	4
BULW 270	Legal Environment of Business	4
BUMG 210	Management Concepts OR	4
BUMG 310	Management Principles	
BUMG 235	Personnel Management OR	4
BUMG 335	Human Resource Management	
BUMG 242	Business Communications OR	4
BUMG 305	Professional Comm. & Dev. Skills	
BUMG 355	Quantitative Methods in Business	4
BUMG 385	Production/Operations Management	4

¹ Accounting principles and computer application are recognized as general education courses according to the AICPA model curriculum.

² Consult your advisor when selecting electives.

Course No.	Course	Cr. Hrs.
BUMG 485	Business Policy/Strategy	4
BUMK 310	Marketing Principles	4
PHIL 331	Business Ethics	4

Bachelor of Science in Business Administration with a Concentration in General Business

The four-year program in general business is designed to provide a broad understanding of business by focusing on all aspects of its dynamics. A broad-based general education precedes an extensive education in general business. Successfully completing this degree program gives you the necessary tools to enter a career in business or to pursue graduate study. **Students planning to pursue graduate degrees are strongly advised to take MATH 190 as an elective.**

The general business program has both a core of business courses and nonbusiness courses. You choose, after consulting with your advisor, at least one upper division course in four of the prescribed elective areas: accounting, automated information systems, finance, management, and marketing. This gives you some flexibility in designing a program which meets your career goals.

Degree Requirements

General Education Program (48 Hours)	44 Hours
<i>MATH 170, required in all BSBA concentrations, satisfies the Quantitative Reasoning component of the GER. Further information is listed on page 55 of the current catalog or can be obtained from the dean's office.</i>	
Business Core Courses	48 Hours
Non-Business Requirements	16 Hours
Upper Division Electives	16 Hours
Other Business Electives	20 Hours
Electives	44 Hours
Total Hours Required	188 Hours

Business Core Courses (48 Hours)

Course No.	Course	Cr. Hrs.
BUAC 201	Financial Accounting Principles	4
BUAC 203	Managerial Accounting Principles	4
BUAI 101	Computer Applications 1	4
BUAI 102	Computer Applications 2	4
BUFI 345	Managerial Finance	4
BULW 270	Legal Environment of Business	4
BUMG 305	Professional Comm. & Dev. Skills	4
BUMG 310	Management Principles	4
BUMG 355	Quantitative Methods in Business	4

BUMG 385	Production/Operations Management	4
BUMG 485	Business Policy/Strategy	4
BUMK 310	Marketing Principles	4

Non-Business Requirements (16 Hours)

ECON 201	Principles of Microeconomics	4
ECON 202	Principles of Macroeconomics	4
MATH 150	Principles of Statistics	4
MATH 170	Applied Finite Mathematics	4

Upper Division Electives (16 Hours)

Choose one 300-400 course from any four of the five areas listed below for a total of 16 credit hours. These hours must be taken at Shawnee State.

- BUAC Accounting
- BUAI Automated Information Systems
- BUFI Finance
- BUMG Management
- BUMK Marketing

Bachelor of Science in Business Administration with a Concentration in Health Management

The bachelor of science in business administration with a concentration in health management helps prepare you for a career in the health care industry. Graduates of the program find employment as health service managers with various organizations, including hospitals, clinics, health maintenance organizations, and nursing homes. In addition, the program provides excellent preparation for graduate study in business or health administration.

Students electing to follow the **extended care track** are eligible to take the State and Federal Nursing Home Administrators' Licensing Exam upon graduation.

Students are required to complete a total of 800 on-site hours in a health care facility by using a combination of BUHE 385, 451, and/or 452.

Accreditation

The health management program's curriculum meets the Board of Nursing Home Administration's (BENHA) standards, and the program has been accredited by the board. This accreditation allows students, who complete the bachelor of science in business administration degree with a concentration in health management, to sit for the state and national nursing home administration exams.

BENHA approves programs whose curriculum provides the content and practical experience necessary for a student to gain the competencies to be a successful licensed nursing home administrator. The program at Shawnee State University is the only business degree program in Ohio with this accreditation.

Career Opportunities

Students choosing the long-term care track in the health management program at Shawnee State are entering a challenging and growing career field. As the population grows older, the needs of the elderly are becoming greater. Graduates with this degree are competent to manage and work in home health, assisted living, and other health facilities designed to care for the elderly.

For students interested in primary care, the health management program offers an acute care track which focuses on management and administrative careers in hospitals, clinics, and managed care. There is also a growing need for individuals to work in these types of facilities.

The health management program offers a solid business base with courses specific in health management and provides the graduate a variety of employment opportunities in the rapidly changing health care environment. This program also provides the necessary courses in preparation for graduate school.

Class Scheduling

Health management courses are offered late in the afternoon and in the evening to accommodate the working professional.

HEALS (Health Executives and Administrators Learning Society)

HEALS is a Shawnee State University recognized student association whose members are health care management students. The local student organization (HEALS) is also a student chapter of the American College of Health Care Executives and The American College of Health Care Administrators.

Both acute care and long term care students are invited to join these chapters. Membership in either of the national chapters allows the student to apply for health management scholarships.

Degree Requirements

General Education Program (48 Hours)	44 Hours
<i>MATH 170, required in all BSBA concentrations, satisfies the Quantitative Reasoning component of the GEP. Further information is listed on page 55 of the current catalog or can be obtained from the dean's office.</i>	
Business Core Courses	48 Hours
<i>See concentration in general business, pg. 134.</i>	
Non-Business Requirements	16 Hours
<i>See concentration in general business, pg. 134.</i>	
Health Management Concentration	58 Hours
Electives	24 Hours
Total Hours Required	190 Hours

Health Management Concentration (58 Hours)

Course No.	Course	Cr. Hrs.
BUAC 410	Health Care Acct./Administration	4
BUHE 300	Medical Term. for Health Managers	4
BUHE 310	Orientation to Health Care Mgt.	4
BUHE 312	Health Care Personnel Management	4
BUHE 385 ¹	Practicum	5
<i>This 1-4 cr. hr. course must be repeated for a total of 5 cr. hrs., not to exceed 4 hrs. in one quarter</i>		
BUHE 410	Patient Care Issues in Long-Term Health Care Facilities OR	4
BUHE 415	Admin. in Acute Care Facilities	
BUHE 411	Admin. in Extended Health Care Facilities OR	4
BUHE 416	Mgt. Issues in Acute Care Facilities	
BUHE 420	Problems & Policies in Health Care Management	4
BUHE 430	Health Care Fin. & Reimbursement	4
BUHE 4512	Internship in Extended Health Care Facilities OR	6
BUHE 4522	Internship in Acute Health Care Facilities	
ETCO 210	Occupational Safety & Health Mgt.	3
GEOG 310	Medical Geography: Geography of Life or Death	4
PSYC 340	Psychology of the Adult	4
PSYC 405	Death and Dying	4

¹ One hour of credit earns 40 hours of on-site volunteer experience.

² All coursework complete and permission.

Bachelor of Science in Business Administration with a Concentration in Legal Assisting

2+2 for students who complete the Legal Assisting Technology Program

This program is designed for students who have completed the associate degree in legal assisting at Shawnee State and who wish to attend law school or to pursue any career—either traditional or nontraditional—which requires paralegal skills or a paralegal background. Some examples of career opportunities for graduates of our program are internal revenue officer, clerk of courts, veterans claims examiner, and computer litigation support.

All required courses in the legal assisting program (100 hours) count toward the baccalaureate requirements. After transferring the legal assisting credits, the bachelor of science student needs to complete 32 hours of the General Education Program requirements and 60 hours of the Business Core.

Degree Requirements

General Education Program (48 Hours) 44 Hours
(32 hours needed after transfer of credits from associate degree program.) MATH 170, required in all BSBA concentrations, satisfies the Quantitative Reasoning component of the GEP. Further information is listed on page 55 of the current catalog or can be obtained from the dean's office.

Business Core Courses 48 Hours
See concentration in general business, pg. 134.
(32 hours needed after transfer of credits from associate degree program.)

Non-Business Requirements 16 Hours
See concentration in general business, pg. 134.

Legal Assisting Curriculum 68 Hours

Electives 16 Hours

Total Hours Required 192 Hours
(92 hours needed after transfer of credits from associate degree program)

Business Core Courses (48 Hours)

"T" indicates that course is transferable from associate degree program.

Course No.	Course	Cr. Hrs.
BUAC 201	Financial Accounting Principles	T
BUAC 203	Managerial Accounting Principles	T
BUAI 101	Computer Applications 1 (BULA 264 = T)	T
BUAI 102	Computer Applications 2	4
BUFI 345	Managerial Finance	4
BULW 270	Legal Environment of Business (BULW 250 = T)	T
BUMG 305	Professional Comm. & Dev. Skills	4

BUMG 310	Management Principles	4
BUMG 355	Quantitative Methods in Business	4
BUMG 385	Production/Operations Management	4
BUMG 485	Business Policy/Strategy	4
BUMK 310	Marketing Principles	4

Legal Assisting Curriculum (68 Hours)

BULA 101	Introduction to Legal Assisting	T
BULA 212	Real Estate Law for Legal Assisting	T
BULA 251	Legal Research & Writing 1	T
BULA 252	Legal Research & Writing 2	T
BULA 261	Tort Law	T
BULA 262	Introduction to Civil Litigation	T
BULA 263	Intro. to Contracts & Restitution	T
BULA 265	Family Law	T
BULA 266	Wills, Trusts, & Estates	T
BULA 267	Legal Assisting Practicum	T
BULA 269	Criminal Law/Criminal Procedures	T
BULA 270	Evidence	T
BULW 260	Business Law 2	T
ENGL 121	Technical Writing	T
GOVT 250	Introduction to Political Science	T
MATH	Mathematics Placement (101 or above)	T
PSYC 101	Introduction to Psychology	T

Bachelor of Science in Business Administration with a Concentration in Management Information Systems

This program is designed for students entering Shawnee State for the first time, as well as for students who have completed the associate degree in business information systems. Most courses in the BIS program count toward the baccalaureate degree.

Degree Requirements

General Education Program (48 Hours) 44 Hours
MATH 170, required in all BSBA concentrations, satisfies the Quantitative Reasoning component of the GEP. Further information is listed on page 55 of the current catalog or can be obtained from the dean's office.

Business Core Courses 48 Hours
See concentration in general business, pg. 134.

Non-Business Requirements 16 Hours
See concentration in general business, pg. 134.

MIS Core Courses 24 Hours

MIS Elective Path 20 Hours

Electives 36 Hours

Total Hours Required 188 Hours

MIS Core Courses (24 Hours)

Course No.	Course	Cr. Hrs.
BUAI 150	Internet & Web Publishing	4
BUAI 301	Hardware/Software/Networking	4
BUAI 310	Intro. to Database with SQL	4
BUAI 320	Systems Analysis & Design	4
BUAI 430	Info. Sys. Deployment & Mgt.	4
BUIS 103	Visual BASIC 1	4

MIS Elective Path (20 Hours)

Choose one of the following MIS elective paths.

PATH 1: PROGRAMMING

Required Courses (12 hours):

BUAI 303	Visual BASIC 2	4
BUAI 330	Object-Oriented Programming	4
BUAI 421	Advanced Database	4

Electives (choose at least 8 hours):

BUIS 105	COBOL Programming 1	4
BUIS 106	COBOL Programming 2	4
BUIS 201	C Language	4
ETCO 116	JAVA Computer Programming	4

PATH 2: WEB

Choose at least 12 hours from the following:

BUAI 303	Visual BASIC 2	4
BUAI 350	Web Design	4
BUAI 360	ASP:Net	4
BUAI 370	E-Commerce	4
BUIS 201	C Language	4

Other Electives:

ARTS 362	Digital Imaging	4
ARTS 467	Website Arts	4
ETCO 116	JAVA Computer Programming	4
ETWB 101	Object Oriented Programming 1	4
ETWB 111	XML 1	4

Associate Degrees

Associate Degree in Applied Business

Our associate degrees in applied business have two goals: to prepare you for the job market and to give you the necessary foundation to advance, if you choose, to the bachelor of science degree program.

There are five areas of study from which you may choose.

- Accounting Technology
- Business Information Systems
- Business Management Technology
- Legal Assisting Technology
- Office Administration Technology

Accounting Technology

The field of accounting offers many career opportunities in both the private and public sector.

■ **Management (Industrial) Accounting** The management accountant is trained to determine the financial consequences of management decisions. The reports and analyses of the management accountant are essential ingredients of most management decisions about finance, investments, and pricing policies. More than anyone else on the management team, the management accountant participates in virtually every phase of the business problem solving and decision making process. Because of the accountant's role in this process, he or she has many times advanced to a top management position within the company.

■ **Governmental Accounting** All organizations need accounting information, and government and other nonprofit organizations are no exception. The federal government hires accountants in most of its agencies. Three prominent agencies are the Internal Revenue Service, the General Accounting Office, and the Defense Contract Audit Agency. State and local government units hire accountants in their tax divisions and in general accounting functions. Schools and hospitals are major users of accounting services. Many opportunities exist for those interested in governmental accounting.

■ **Public Accounting and the CPA** For the protection of the public, the CPA is expected to possess certain professional qualifications. The Uniform CPA Examination measures the technical competency, the exercise of good judgement, and the understanding of professional responsibility of each man or woman who chooses this career in accounting. The public accountant is a true independent professional person with the stature of a doctor or lawyer. In public accounting many opportunities exist for professional growth, whether you practice as a sole practitioner or as part of a larger firm.

Class Scheduling

Shawnee State makes every effort to offer associate degree accounting classes in day and evening sections.

Sample Schedule

Students planning to pursue a baccalaureate degree should contact an accounting advisor for course substitutions. The associate degree is fully articulated with the B.S.B.A., accounting concentration.

Course No.	Course	Cr. Hrs.
FIRST QUARTER		
BUAC 101	Accounting 1	4
BUAI 101	Computer Applications 1	4
BUMG 101 ¹	Introduction to Business	4
ENGL 111S	Discourse & Composition	4
	Total	16
SECOND QUARTER		
BUAC 102	Accounting 2	4
ECON 202	Principles of Macroeconomics	4
ENGL 112S	Composition & Research	4
MATH XXX ²	MATH 101 or higher	4
	Total	16
THIRD QUARTER		
BUAC 103	Accounting 3	4
BUAC 110	Payroll Accounting	4
ENGL 115S	Composition & Literature	4
MATH XXX	MATH 125 or higher	4
	Total	16
QUARTER OF CHOICE		
BUOA 215	Spreadsheet Applications	4
	Total	4
FOURTH QUARTER		
BUAC 221	Cost Accounting 1	4
BUAC 231	Intermediate Accounting 1	4
BUFI 245	Principles of Finance	4
BUMG 210	Management Concepts OR	4
BUMG 310	Management Principles	4
	Total	16
FIFTH QUARTER		
BUAC XXX ³	Elective	4
BUAI/BUIS ³	Elective	4
BULW 250	Business Law 1	4
ECON 201	Microeconomics	4
	Total	16
SIXTH QUARTER		
BUAC 215	Tax Accounting	4
BUAC XXX ³	Elective	4
BUMG 242	Business Communications OR	4
BUMG 305	Prof. Communication & Dev. Skills	4
PSYC/SOCI	PSYC 101 or SOCI 101 or SOSC 110S	4
	Total	16

The A.A.B. in accounting technology requires a minimum of 100 credit hours.

Business Information Systems

The business information systems associate degree program at Shawnee State University is designed to meet the manpower demand of industries, government, and educational institutions.

In addition to theoretical fundamentals, practical aspects of computer systems in business are emphasized. Hands-on opportunity is provided and encouraged.

Graduates of this program are fully prepared to enter employment as computer programmers, operators, or microcomputer specialists in computer installations or application departments. Graduates of this program receive an associate degree in applied business and are eligible to apply their associate degree courses towards a bachelors degree in business administration with a concentration in management information systems. For more details, please schedule a meeting with an advisor in that field.

Class Scheduling

Most computer classes are offered in both the day and evening sections. See your advisor.

Sample Schedule

Course No.	Course	Cr. Hrs.
FIRST QUARTER		
BUAC 101	Accounting 1	4
BUAI 101	Computer Applications 1	4
BUOA 108 ⁴	Beginning Document Processing	4
ENGL 111S	Discourse & Composition	4
MATH ²	Mathematics Requirement	4
	Totals	20
SECOND QUARTER		
BUAC 102	Accounting 2	4
BUAI 102	Computer Applications 2	4
BUIS 103	Visual BASIC 1	4
ENGL 112S	Composition & Research	4
	Totals	16
THIRD QUARTER		
BUAC 103	Accounting 3	4
BUAI 150	Internet & Web Publishing	4
ENGL 115S	Composition & Literature	4
MATH ²	Mathematics Requirement	4
	Totals	16

¹ Students with previous business experience may substitute an upper level BUMG course.

² Student placement in mathematics courses depends on placement test results. All BUIS majors must take at least eight credit hours of mathematics at or above MATH 101.

³ Consult your advisor when selecting electives.

⁴ Students having prior credit in typing may receive "K" credit for this course.

FOURTH QUARTER		
BUIS 201	C Language	4
BUIS ¹	Elective	4
BULW 250	Business Law 1	4
ENGL 121	Technical Writing	4
SOCI/SOSC	Social Science Elective	4
	Totals	20
FIFTH QUARTER		
BUAI/BUIS ¹	Elective	4
BUMG 210	Management Concepts	4
BUIS 203	Business Computer Projects	4
ECON 202	Principles of Macroeconomics	4
	Totals	16
SIXTH QUARTER		
BUAI/BUIS ¹	Electives (3)	12
MATH 150	Principles of Statistics	4
	Totals	16

The A.A.B. in business information requires a minimum of 104 credit hours.

Business Management Technology

Management is the ability and skill to develop a plan, to organize people and other resources, and to guide and motivate others to achieve some desired result. All organizations are trying to achieve some goal; therefore, all organizations need people with managerial knowledge and skills to help them accomplish their goals. For this reason, there are many diverse job opportunities available to people who possess management knowledge and skills.

Whether you're just entering the job market or returning to college to improve your job opportunities, the business management program includes courses that will help you gain the knowledge and skills you need to analyze an organization's problems and to develop, organize, communicate, and implement solutions to those problems. Much of this knowledge and many of these skills are universal—they apply to all kinds of organizations at many levels. When you complete the program you are equipped to begin your career in various entry-level supervisory, administrative, management trainee, or sales positions.

Degree Requirements

Nonbusiness Courses	31 Hours
Business Courses	68 Hours
Total Hours Required	99 Hours

Nonbusiness Courses (31 Hours)

Course No.	Course	Cr. Hrs.
ECON 201	Principles of Microeconomics	4
ECON 202	Principles of Macroeconomics	4
ENGL 111S	Discourse & Composition	4
ENGL 112S	Composition & Research	4
ENGL 115S	Composition & Literature	4
MATH XXX	MATH 125 Business Mathematics (or higher)	4
SOCI XXX	SOCI 101 or SOSC 110S	4
SPCH 103	Public Speaking & Human Comm.	3

Business Courses (68 Hours)

BUAC 101	Accounting 1	4
BUAC 102	Accounting 2	4
BUAI 101	Computer Applications 1	4
BUFI 240	Personal Finance	4
BUFI 245	Principles of Finance	4
BUFI 250	Introduction to Investments	4
BULW 250	Business Law 1	4
BULW 260	Business Law 2	4
BUMG 210	Management Concepts	4
BUMG 235	Personnel Management	4
BUMG 242	Business Communications	4
BUMG 285	Enterprise Management & Strategy	4
BUMK 210	Marketing Concepts	4
BUMK 220	Salesmanship	4
BUMK 235	Advertising	4
BUXX XXX	Business Elective	4

Choose one:

BUAI 102 ²	Computer Applications 2	4
BUOA 215	Spreadsheet Applications	4

Class Scheduling

Some business management courses are offered only in the evening and some are offered only once per year. Consult your advisor when scheduling.

Sample Schedule

Course No.	Course	Cr. Hrs.
FIRST QUARTER		
BUAC 101	Accounting 1	4
BUMG 210	Management Concepts	4
ENGL 111S	Discourse & Composition	4
MATH XXX	MATH 125 or higher	4
	Total	16
SECOND QUARTER		
BUAC 102	Accounting 2	4
BUAI 101	Computer Applications 1	4
BUMK 210	Marketing Concepts	4
ENGL 112S	Composition & Research	4
	Total	16

¹ Consult your advisor when selecting electives.

² For those transferring into the BSBA program.

Course No.	Course	Cr. Hrs.
THIRD QUARTER		
BUAI 102	Computer Applications 2 OR	4
BUOA 215	Spreadsheet Applications	
BUFI 240	Personal Finance	4
BUXX XXX	Business Elective (<i>BUAC 103¹ or any 200 level or higher in BUMG, BUFI, or BUMK</i>)	4
ENGL 115S	Composition & Literature	4
SPCH 103	Public Speaking & Human Comm.	3
	Total	19
FOURTH QUARTER		
BUFI 245	Principles of Finance	4
BULW 250	Business Law 1	4
BUMG 242	Business Communications	4
ECON 202	Principles of Macroeconomics	4
	Total	16
FIFTH QUARTER		
BUFI 250	Introduction to Investments	4
BULW 260	Business Law 2	4
BUMK 220	Salesmanship	4
ECON 201	Principles of Microeconomics	4
	Total	16
SIXTH QUARTER		
BUMG 235	Personnel Management	4
BUMG 285	Enterprise Management & Strategy	4
BUMK 235	Advertising	4
SOCI XXX	SOCI 101 or SOSC 110S	4
	Total	16

Legal Assisting Technology

Legal assistants perform many tasks under the supervision of attorneys. Their responsibilities may include:

- Legal and factual research
- Interviewing clients and witnesses
- Reviewing and organizing material for cases
- Drafting legal documents and forms
- Functioning as a member of a legal team

Jobs for the legal assistant vary in scope and nature from small to large law firms, financial institutions, corporations, law courts, insurance agencies, banks, department stores, credit departments, and health care facilities. It is one of the fastest growing areas of employment in the United States today.

Career Opportunities

A paralegal's job title may reflect the type of law practiced by their employer, for example,

administrative law, banking, bankruptcy, or corporate paralegal. Paralegals are also employed in the areas of criminal, domestic relations, employee benefits, environmental, family, health care, insurance, oil and gas, and worker's compensation law as well as in estate planning and litigation.

Positions in the federal government which may require a paralegal background include: clerk of courts, civil service retirement claims examiner, compliance inspector, contract representative, criminal investigator, customs inspector, customs patrol officer, dependents and estates claims examiner, equal opportunity assistant, general claims examiner, insurance examiner, internal revenue officer, legal clerk, mediator, railroad retirement claims examiner, securities compliance examiner, social insurance claims examiner, unemployment compensation claims examiner, veterans claims examiner, and worker's compensation claims examiner.

Nontraditional career positions which require either paralegal skills or a paralegal background, but may or may not utilize the terms "paralegal" or "legal assistant," include: administrative assistant, case manager coordinator, case manager, computer litigation support, executive assistant, human resources staff analyst, legal research aide, litigation manager, project coordinator, resource coordinator, and title clerk.

Goals of the Program

The legal assisting program has clearly established goals designed to meet the unique needs of our students, potential employers of our graduates, and the mission of Shawnee State University. Our goals are as follows: (1) to graduate ethically responsible legal assistants who work under the direction and supervision of attorneys and who are conscious of the prohibitions against the unauthorized practice of law; (2) to create and maintain a program responsive to the needs of its constituency; (3) to strive to qualify graduates who will contribute to the advancement of the profession, rather than to serve only the purposes of one institution or locality; and (4) to develop the student's sensitivity to emerging concepts regarding the role of the legal assistant in the effective delivery of legal services in both the private and public sectors of our society.

The legal assisting courses at Shawnee State are not theory courses, but rather practical "how to"

¹ For those transferring into the BSBA program.

courses taught by attorneys and judges who have specialized in the area in which they teach.

Class Scheduling

Because most of the legal assisting (BULA) courses are taught by attorneys and judges, these courses are most often offered in the evening sections.

Sample Schedule

Course No.	Course	Cr. Hrs.
FIRST QUARTER		
BULA 101	Introduction to Legal Assisting	4
BULW 250	Business Law 1	4
ENGL 111S	Discourse & Composition	4
MATH XXX	MATH 101 <i>or higher</i>	4
	Total	16
SECOND QUARTER		
BULA 251	Legal Research & Writing 1	4
BULW 260	Business Law 2	4
ENGL 112S	Composition & Research	4
SOSC 110S	Foundations of Social Science OR	4
SOCI 101	Introduction to Sociology	4
	Total	16
THIRD QUARTER		
BULA 252	Legal Research & Writing 2	4
BULA 262	Introduction to Civil Litigation	4
GOVT 250	Introduction to Political Science	4
PSYC 101	Introduction to Psychology	4
	Total	16
FOURTH QUARTER		
BULA 261	Tort Law: Personal Injury Litigation	4
BULA 263	Intro. to Contracts & Restitution	4
BULA 264	Computer Applications & the Law	4
BULA 269	Criminal Law/Criminal Procedure	4
	Total	16
FIFTH QUARTER		
BUAC 101	Accounting 1	4
BULA 212	Real Estate Law for Legal Assistants	4
BULA 265	Family Law	4
BULA 270	Evidence	4
	Totals	16
SIXTH QUARTER		
BUAC 102	Accounting 2	4
BULA 266	Wills, Trusts, & Estate Administration	4
BULA 267	Legal Assisting Practicum	4
ENGL 121	Technical Writing	4
PHIL 320S1	Ethics in Public & Private Life OR	4
PHIL 3311	Business Ethics OR	4
BULA 2721	Ethics for Legal Assistants	4
	Total	20

The A.A.B. in legal assisting technology requires a minimum of 100 credit hours.

Office Administration Technology

Various positions are available after completion of the office administration program. The graduate is qualified to fill a broad range of office positions which require technical skills. The program includes training in the preparation of medical documents, the creation of publications using desktop publishing, the use of transcription equipment, and an extensive study of office communications skills.

Graduates are trained in the functions of Word, Access, PowerPoint, Excel, and Outlook software.

Class Scheduling

Office administration courses are normally offered only in the day sections. See your advisor.

Sample Schedule

Course No.	Course	Cr. Hrs.
FIRST QUARTER		
BUAC 101 ²	Accounting 1 <i>or business elective</i>	4
BUMG 210	Management Concepts	4
BUOA 108 ³	Beginning Document Processing	4
ENGL 111S	Discourse & Composition	4
	Total	16
SECOND QUARTER		
BUAC 102 ²	Accounting 2 <i>or business elective</i>	4
BUOA 221	Word Processing 1	4
ENGL 112S	Composition & Research	4
XXX ⁴	GEP Social Science elective	4
	Total	16
THIRD QUARTER		
BUAC 103 ²	Accounting 3 <i>or business elective</i>	4
BUOA 130	Records Management	4
BUOA 222	Word Processing 2	4
ENGL 115S	Composition & Literature	4
	Total	16
FOURTH QUARTER		
BULW 250	Business Law 1	4
BUOA 111	Office Communications 1	4
BUOA 217	Office Computer Applications	4
BUOA 230	Desktop Publishing 1	4
	Total	16

¹ Students must take either PHIL 320S or 331 if they wish to earn transfer credit which will apply to the B.S.B.A./Legal Assisting 2+2.

² Students contemplating transfer to the B.S.B.A. degree should take Accounting 1, 2, and 3. Business electives exclude BUAI 101, 102, and 310.

³ Students having prior credit in typing may receive "K" credit for this course.

⁴ See the General Education program beginning on page 55.

Course No.	Course	Cr. Hrs.
FIFTH QUARTER		
BUOA 215	Spreadsheet Applications	4
BUOA 112	Office Communications 2	4
BUOA 241	Office Administration 1	4
BUOA 244	Medical Office Administration	4
XXX ¹	GEP elective	4
	Total	20
SIXTH QUARTER		
BUFI 240	Personal Finance OR	4
MATH XXX	MATH 105, 125 <i>or higher</i>	4
BUMG 235	Personnel Management	4
BUOA 214	Microcomputer Office Practice	4
BUOA 242	Office Administration 2	4
	Total	16

The A.A.B. in office administration requires a minimum of 100 credit hours.

Minors

Business Administration

The minor in business administration provides the opportunity for non-business students to gain common business knowledge and skills that enhance future supervisory and management career opportunities in diverse types of organizations. In addition, the minor covers most of the basic business courses required as prerequisites in many MBA programs.

Required Courses

Course No.	Course	Cr. Hrs.
BUAC 201	Financial Accounting Principles	4
BUAC 203	Managerial Accounting Principles	4
BUAI 101	Computer Applications 1	4
BUFI 245	Principles of Finance	4
BULW 270	Legal Environment of Business	4
BUMG 310	Management Principles	4
BUMK 310	Marketing Principles	4
BUOA 215	Spreadsheet Applications	4

Health Management

The health management minor is designed for students enrolled in clinical health care programs who wish to develop their managerial skills. (It should be noted that the minor does not qualify a person to sit for the national and state nursing home license exam.) The minor requires 28 hours

of health management courses. Please check the course description section of this catalog to see whether prerequisites need to be met.

Required Courses

Course No.	Course	Cr. Hrs.
BUHE 310	Orientation to Health Care Systems	4
BUHE 312	Health Care Personnel Management	4
BUHE 410	Patient Care in Ext. Care Facil. OR	4
BUHE 415	Admin. in Acute Care Facilities	4
BUHE 411	Admin. in Extended Care Facil. OR	4
BUHE 416	Mgt. Issues in Acute Care Facilities	4
BUHE 420	Prob. in Health Care Mgt. & Policy	4

Optional Courses

Complete at least 8 hours from the following.

BUAC 410	Health Care Accounting/Admin.	4
BUHE 314	Community Health Programs	4
BUHE 430	Health Care Reimb. & Payments	4
BULW 270	The Legal Environment of Business	4
BUMK 310	Marketing Principles	4

BUHE 410, 411, 415, or 416 are also optional if not taken as one of the required courses.

¹ See the General Education program beginning on page 55.



HEALTH SCIENCES

Health Sciences

The Department of Health Sciences serves the tri-state area by educating and preparing competent and responsible health-care professionals so that they can deliver the best quality health care possible. The Department of Health Sciences also fosters professionalism, personal growth and development, and self-actualization and is committed to continuing professional development for the health care practitioners in the tri-state area.

For General Information

Martha C. Rader, Ph.D., Dean
Ann McCarthy, Secretary
College of Professional Studies
Health Sciences Building
Phone: 740.351.3270
Fax: 740.351.3354
E-mail: amccarthy@shawnee.edu

For Health Sciences Admission Information

Cindy Haney, Health Sciences Representative
Office of Admission
Shawnee State University
940 Second Street
Portsmouth, Ohio 45662-4344
Phone: 740.351.3209
Fax: 740.351.3111
E-mail: chaney@shawnee.edu

Programs in the Health Sciences

Bachelor of Individualized Studies

See page 128 of current catalog for description.

Bachelor of Science

Nursing (RN-BSN)
Occupational Therapy (*To be discontinued.*)

Associate of Applied Science

Associate Degree Nursing
Dental Hygiene
Emergency Medical Technology
Medical Laboratory Technology
Occupational Therapy Assistant
Physical Therapist Assistant

Radiologic (X-ray) Technology
Respiratory Therapy

Associate of Individualized Studies

See page 129 of current catalog for description.

Selective Admission Criteria

Fulfilling the criteria for admission into a health sciences program does not automatically guarantee entrance into the program. Since the number of candidates who meet the minimal criteria for admission generally far exceeds the number of vacancies, each program ranks the candidates using selected criteria in addition to the minimal admission requirements. For example, additional criteria may include, but is not limited to, high school and/or college grade point average; completion of additional coursework in college level biology, mathematics, and chemistry; work experience; and autobiographies. You may obtain information about the criteria used for the ranking of applicants by contacting the department's chairperson.

Hospital Clinical Sites

Some health science programs utilize hospital clinical sites for the completion of their requirements for graduation. These affiliating hospitals have the right to accept or reject a student, which could result in your being delayed in a program or unable to complete the requirements for graduation. If you have a conviction record for certain classes of misdemeanors or any felony, you may be ineligible for licensure in specific health occupations. Also, the affiliating hospitals have the right to reject students due to a criminal record.

Health Science Class Scheduling

The majority of all health science classes are scheduled between 8:00 a.m. and 5:00 p.m. However, you need to know that it may be necessary to schedule your required classes in English, natural sciences, and humanities during the evening hours as the required clinical and laboratory times in the health science courses involve many hours during the 8:00 to 5:00 day schedules.

Pass/No-Credit Policy

Students in health science programs are not permitted to take courses on a pass/no-credit basis. This applies to courses taken in preparation for

admission to the health science programs as well as courses taken after admission to a program. Classes may be taken for non-credit, but only with the prior permission of the health science department's chairperson.

Guidelines for Appealing a Dismissal From a Health Science Program

Each of the programs within the Department of Health Sciences has set minimum academic and clinical performance standards which permit a student to continue in that program. Failure to meet these minimum performance standards will result in dismissal from the program. Information concerning these performance standards is available in this catalog, the student handbook for the individual program, or from the office of the program's chairperson.

If you wish to appeal your dismissal from a health science program, the following sequence of events shall be followed:

- Within three working days following your notification of dismissal from the health science program, you must request in writing a meeting with the program's chairperson to appeal the dismissal. You will be notified of the results of this appeal within two working days following this meeting. If you are unsatisfied with the decision, you may request, within three working days, a second appeal hearing.
- Upon your written request for the next level of appeal, the program's chairperson will arrange a joint meeting with you, the chairperson (or designee), the dean of the College of Professional Studies (or designee), and the provost (or designee). You will be notified of the results of this appeal hearing within two working days following the meeting.

Criteria to be used in ruling on your dismissal appeal include your past academic achievement, your rationale for current grade status, and the prediction of future performance in the program.

Dismissal from a health science program is not the same as dismissal from the University. University dismissal policies are outlined in this catalog under the section titled "Academic Policies."

Bachelor Degrees

Bachelor of Science in Nursing (RN-BSN)

The Department of Nursing promotes the mission of Shawnee State University and the profession of nursing. The Department supports this mission by adhering to the philosophy and its curriculum, which implies responsibility for development, implementation, and revision. Faculty endeavor to help students develop self, critical thinking, and skills to enhance their function as bachelor prepared graduates who contribute to both the profession and society.

The bachelor of science in nursing (RN-BSN) program builds on the foundation of associate degree or diploma education and prepares the registered nurse for professional nursing practice in a variety of settings. Graduates of the RN-BSN program are prepared for leadership positions and for graduate study. Clinical experiences are provided in a variety of health care settings, such as hospitals, health departments, clinics, nursing homes, mental health centers, and other health-related community agencies. The program is available to qualified registered nurses.

In addition to achieving the professional goals of the RN-BSN program, students also complete a liberal arts education described elsewhere in this catalog as the General Education Program (GEP).

The RN-BSN program offers flexible scheduling, with the majority of the nursing coursework available through distance learning methods, including online education and use of clinical preceptors.

Accreditation

The program is accredited by the National League for Nursing Accrediting Commission.

Admission Requirements

Admission is determined on a competitive basis. The total number of students admitted to the program is based upon available facilities and faculty. Students are admitted into the program quarterly through a rolling admission process.

Criteria for admission: Graduation and transcript from an associate's degree or diploma nursing program; a college GPA of 2.7 or better on a 4.0 scale or 2.5-2.69 with 2 years full-time clinical practice (or part-time equivalent) and

written recommendation from recent clinical supervisor; a nonrestricted, active, valid RN license; current immunizations; CPR Healthcare Provider certification; completion of health physical; and health and liability insurance.

Application Materials

Application materials are available from the Office of Admission or the Department of Nursing. Students who have completed application materials are considered for acceptance on the basis of space available in the program and the academic qualifications of the student.

Program Requirements

The Department of Nursing considers a grade of C (2.0) as the minimum passing grade for all required nursing and non-nursing courses. Courses graded with less than a C will result in academic dismissal from the program. Readmission to the nursing program is determined by the Department of Nursing policies as printed in the current Department of Nursing *Student Handbook*.

Guidelines for clinical preceptors are available in the nursing office.

Students are responsible for verifying they have met degree requirements for graduation.

Degree Requirements¹

General Education Program (48 Hours)	40 Hours
<i>The Natural Science component (Option 2) of the GEP is satisfied by the requirements of the bachelor of science in nursing. See page 55 of the current catalog for further information about the GEP.</i>	
Other Non-Nursing Courses	39 Hours
Required Lower Division	59 Hours
Nursing Courses <i>from ADN or diploma program</i>	
Required Upper Division Nursing/ Health Science Courses ²	49 Hours
Minimum Hours Required	187 Hours

Other Non-Nursing Courses (39 Hours)

These courses should include those in anatomy/physiology, microbiology, pathophysiology, chemistry, and social sciences.

Required Upper Division Nursing/Health Science Courses (49 Hours)

Course No.	Course	Cr. Hrs.
AHNR 354	Teaching/Learning in the Hlth. Sci.	4
BSNR 341	Transcultural Nursing	4
BSNR 342	Nursing Informatics	4
BSNR 343	Research & Decision Making in Nursing	4
BSNR 345	History, Theory, & Trends in Nursing	4
BSNR 363	Health Appraisal & Physical Assessment (Lab)	4
BSNR 451	Family Nursing in the Community	5
BSNR 453	Leadership & Management in Nursing (Clinical)	5
BSNR 454	Community & Public Health Nursing (Clinical)	5
BSNR 462	Innovations & Adaptations (Clinical)	6
BSNR 495	Special Topics in Nursing	4

Bachelor of Science in Occupational Therapy

Upcoming Changes to OT – Last BOT Class Acceptance, April 1, 2003

Nationwide, occupational therapy programs that provide education for occupational therapists (currently the bachelor's degree at Shawnee State University) will be transitioning to a master's level of education for entry level preparation of occupational therapists. This transition will be completed by January 1, 2007, and the Department of Occupational Therapy at SSU is currently exploring options to meet these new educational requirements. Please feel free to contact Debra Scurlock, program director, with any questions you have about this upcoming change.

Occupational therapy is a vital health care service that uses "occupation," meaning purposeful activity, as the basis for treatment of people with a wide variety of physical, developmental, and emotional disabilities.

Occupational therapists help disabled people of all ages acquire or regain the skills they need to live independent, productive, and satisfying lives. They work in hospitals, rehabilitation centers, nursing homes, public and private schools, and home health agencies.

Occupational therapists are responsible for evaluating clients and developing treatment plans

¹ Certain courses are currently under review. See the department chairperson before registration or for advising and details.

² Lab/clinical hours: 1 credit hour = 3 lab/clinical hours

to assist clients in achieving their goals. They provide functional treatment activities for clients individually and in groups, and they choose or fabricate equipment that helps people function more independently. Occupational therapists supervise certified occupational therapy assistants in carrying out treatment plans and possess skills to work with a variety of allied health professionals.

To become an occupational therapist, a student must complete an educational program in occupational therapy at the graduate level by 2007. Studies include basic academic courses in the sciences and liberal arts as well as occupational therapy theoretical constructs and practices. The bachelor's degree in occupational therapy program requires six to nine months of full-time (usually 40 hours per week) internships in a variety of health care settings. You are responsible for your own transportation to and from clinical facilities as well as any other costs associated with clinical placements.

To ensure continuity of application of academic concepts, all fieldwork must be completed within 24 months following academic preparation and 2 months prior to the NBCOT Certification Examination date.

Accreditation

The occupational therapy program is accredited by the Accreditation Council for Occupational Therapy Education (ACOTE) of the American Occupational Therapy Association (AOTA), located at 4720 Montgomery Lane, P.O. Box 31220, Bethesda, MD 20824-1220. AOTA's phone number is 301.652.AOTA. Graduates of the program are able to sit for the national certification examination for the occupational therapist administered by the National Board for Certification in Occupational Therapy, Inc. (NBCOT); however, the NBCOT sets its own criteria for taking the exam, which may include questions on the applicant's criminal history. For more information on these limitations, you can contact NBCOT at 301.990.7979. After successful completion of this exam, you are an occupational therapist, registered (OTR). Most states require licensure in order to practice; however, state licenses are usually based on the results of the NBCOT Certification Examination.

Note: Admission requirements, deadlines, degree requirements, and required courses may change as the undergraduate degree program is discontinued. New information will be available pending approval of the graduate program.

Admission Requirements

Due to limited enrollment for this program, a selective admission process is followed.

Students with a standing of second quarter freshmen or more are considered for admission to the occupational therapy bachelor's program. Students will be admitted to the professional courses during winter quarter.

Candidates are selected from applicants who have met the following *minimum* criteria:

- Application to Shawnee State University with current, nonrefundable application fee (new students).
- "Change of Major" form, indicating application to occupational therapy B.S. program (current students).
- Cumulative GPA of 2.5 or above on a 4.0 scale based on courses listed under 'A' below.
- Cumulative GPA of 2.5 or above on a 4.0 scale at time of enrollment in the professional program.
- A minimum grade of C in all prerequisite courses at time of application.
- Completion of high school level chemistry courses with a grade of C or higher. Students lacking high school chemistry can take CHEM 101 in preparation for college level chemistry elective requirement.
- Completion of 40 hours verified volunteer experience in an occupational therapy setting *OR* certification as an occupational therapy assistant (proof of certification is required).
- Completion of the following courses at the time of application: (*Check course prerequisites in the "Course Description" section of the current university catalog. More coursework may be necessary than is indicated here.*)
 - AHNR 102 (Medical Terminology)
 - BIOL 151 or NTSC 110S
 - ENGL 111S, 112S
 - Fine arts GEP course
 - Mathematics (MATH 110S, 130, or 150)
 - PSYC 101
 - SOCI 101
- Successful completion of the following courses prior to admission to the program: (*Check course prerequisites in the "Course Description" section of the current university catalog. More coursework may be necessary than is indicated here.*)
 - BIOL 151
 - BIOL 310

- BUAI 101 or BUIS 101
- CHEM elective
- Cultural perspectives, 4 of 8 hours
- ENGL 115S
- MATH 150
- NTSC 110S
- PHYS 201
- PSYC 151

■ Completion of all required forms and requested materials by the application deadline.

Requirements for graduation and to remain in the program are listed in the *OT Student Handbook*.

Deadline for Receipt of ALL Application Materials:

After the April 1 deadline, students who have completed application materials may be considered for acceptance on the basis of space available in the program and the academic qualifications of the student.

Degree Requirements

General Education Program (48 Hours) 32 Hours

The GEP is composed of 48 credit hours of which 16 are satisfied by the following "other required courses" requirements: NTSC 110S, BIOL 311, MATH 150, and SOCI 101. Further information about the GEP is listed on page 55 of the current catalog or can be obtained from the dean's office.

Required OT Courses 91-103 Hours

Other Required Courses 77 Hours

Minimum Hours Required 204-212 Hours

Required Occupational Therapy Courses (91-103 Hours)

Course No.	Course	Cr. Hrs.
OTST 101	Intro. to Occupational Therapy	4
OTST 103	Disease Pathology 1	4
OTST 110	Group Dynamics	2
OTST 205	Therapeutic Media	3
OTST 206	Contemporary Media in OT	2
OTST 305	Disease Pathology 2	4
OTST 310	Practicum 1 for OTS	2
OTST 330	Orthotics	3
OTST 410	OT in Physical Disabilities 1	4
OTST 411	OT in Physical Disabilities 2	4
OTST 412	OT in Mental Health 1	4
OTST 413	OT in Mental Health 2	4
OTST 416	OT in Gerontology	4
OTST 420	Practicum 2 for OTS	2
OTST 421	Practicum 3 for OTS	2
OTST 430	OT in Developmental Disabilities 1	5
OTST 431	OT in Developmental Disabilities 2	4
OTST 450	Research Designs & Methods in OT	4

OTST 451	OT Mgt. & Program Planning	4
OTST 495	Clinical Application 1	12
OTST 496	Clinical Application 2	12
OTST 497	Clinical Application 3 (Optional)	4, 8, or 12
OTST 499	Topics in Occupational Therapy	2

Other Required Courses (77 Hours)

AHNR 102	Medical Terminology	2
AHNR 135	Wellness & Health Promotion	3
AHNR 199	Rehabilitation Ethics	2
AHNR 299	Rehabilitation Topics	2
BIOL 151	Principles of Biology	5
BIOL 310	Principles of Anatomy	5
BIOL 311	Kinesiology	4
BIOL 314	Human Neuroanatomy	5
BIOL 320	Principles of Physiology	5
BUAI 101	Computer Applications 1 OR	4
BUIS 101	Intro. to Computer Info. Systems	
BUHE 310	Orientation to Healthcare Systems	4
CHEM	Elective	4
MATH 150	Principles of Statistics	4
PHYS 201	Physics 1 (Mechanics)	4
PSYC 101	Introduction to Psychology	4
PSYC 151	Human Growth & Development	4
PSYC 290	Psychological Tests & Measurements	4
PSYC 400	Abnormal Psychology	4
SOCI 101	Introduction to Sociology	4
SOCI 320	Sociology of Culture	4

Associate Degrees

Minimum Admission Requirements for Associate Degree Programs

The following requirements apply to all associate degree health science programs:

- New students must submit an application to Shawnee State University, along with the current nonrefundable application fee.
- Current Shawnee State students wishing to apply for admission to a health science associate degree program should complete a "Change of Major" form, indicating the program(s) for which they are applying.
- Official high school transcript or GED test score transcript (along with partial high school transcript) and official college transcripts must be submitted.

Please note: Transcripts may be sent directly from the high school or applicants may hand-carry the transcript in an envelope sealed with a guidance counselor's signature. Guidance counselors or high school officials may send transcripts via FAX to 740.351.3111 if accompanied by a signed transmittal form or by electronic transfer. The University reserves

Associate Degree Admission Requirements

	High School or College Algebra, Biology, and Chemistry (C or above)	20 Hours Volunteer or Work Experience with Disabled or Handicapped	ACT Score of 18 in Science Reasoning Section	Comprehensive ACT Score of 18 or Above	SSU MATH/ ENGL Placement Score OR Transfer Credit Equivalent to:
Associate ^{1,2} Degree Nursing	✓		✓ ³	✓ ⁷	ENGL 111S MATH 130
Dental Hygiene	✓		✓		
Emergency Medical Technology	✓				
Medical Laboratory ²	✓		✓ ³		ENGL 111S MATH 130
Occupational Therapy Assistant	✓	✓ ⁴			
Physical Therapist Assistant	✓	✓ ⁵		✓ ⁷	ENGL 111S MATH 101
Radiologic Technology ⁶	✓		✓		ENGL 111S MATH 130
Respiratory Therapy ⁶	✓		✓		ENGL 111S MATH 130

The chart above indicates requirements of individual associate degree health science programs.

¹ Applicants with 30 hours of college credit are required to have a GPA of 2.5 or above on a 4.0 scale.

² Lower placement scores will be accepted on the condition that the student has successfully completed prerequisite coursework for ENGL 111S and/or MATH 130 prior to entry into the MLT or nursing programs.

³ Exceptions may be made if the student has demonstrated successful completion of required chemistry and/or biology courses.

⁴ Applicants to the occupational therapy assistant program must work/volunteer under the direct supervision of either a licensed occupational therapy assistant or occupational therapist.

⁵ Applicants to the physical therapist assistant program must work/volunteer under the direct supervision of either a licensed physical therapist or physical therapist assistant.

⁶ Radiologic technology and respiratory therapy applicants must be eligible to enter MATH 130 and ENGL 111S as the program curriculum describes.

⁷ Nursing and PTA applicants must have a score of 18 in all ACT sections or successfully complete selected college courses in mathematics and science.

the right to verify the final, official authenticity of any student's transcript. Any transcript document found to be fraudulent becomes the student's responsibility and the University reserves the right to withdraw admission acknowledgement and/or approval of acceptance.

College transcripts must be sent directly from the school to Shawnee State to "be official." Photocopies, fax, and hand-carried transcripts are not accepted.

- Students must have a C or above in algebra, biology, and chemistry requirements. A "C-" is not accepted. Students with a C- average in one of these courses are not considered for admission.
- If the ACT test was taken before October 1989, students must have a score of 16 in the published requirement areas. On tests taken October 1989 or later, students must have a score of 18 in the published requirements.
- Students may be required to complete an "Autobiography Form," which is provided to students after the application to the University is received.
- Applicants to the physical therapist assistant or occupational therapy assistant programs are required to complete a minimum of 20 hours volunteer or work experience in a facility serving the disabled or handicapped. OTA applicants must work under the direct supervision of either a licensed occupational therapy assistant or occupational therapist. Applicants to the PTA program must work under the direct supervision of either a licensed physical therapist or physical therapist assistant. Appropriate forms are provided to students after the application to the University is received.
- When all minimum admission criteria have been met, files are forwarded to the appropriate department's chairperson. Students are not considered for admission to a health science program until all minimum admission requirements are completed.
- Applicants to the medical laboratory and respiratory therapy programs must schedule a meeting with the department's chairperson when their file is complete. Applicants to other programs are contacted if further information is needed.

- Physical examinations are required for students who have been officially accepted into a health science program. Forms are provided by the individual departments.

Questions regarding admission procedures or application status should be directed to the health sciences representative in the Office of Admission at 740.351.3209.

Deadline for Receipt of ALL Application Materials:

After the application deadlines listed below, students who have completed application materials may be considered for acceptance on the basis of space available in the program and the academic qualifications of the student.

February 1

Associate Degree Nursing

April 1

Medical Laboratory
Respiratory Therapy

April 15

Dental Hygiene
Radiologic Technology

May 1

Physical Therapist Assistant

May 15

Occupational Therapy Assistant

Rolling Admission

Emergency Medical Technology
RN-BSN Nursing

Associate Degree Nursing

Shawnee State's associate degree nursing program began in 1969. For over 30 years, the ADN program has graduated quality nurses who have assumed multiple roles in health care facilities in the community, region, and across the nation.

The awarding of the ADN does not license one as a registered nurse. The board of nursing in the state in which the applicant wishes to be registered administers a separate examination (NCLEX-RN). The Department of Nursing certifies completion of degree requirements, but meeting other requirements for licensure is the responsibility of each candidate.¹ After successfully passing this examination, graduates are licensed as registered nurses

¹ Conviction of certain classes of misdemeanors or any felony conviction requires permission from the board of nursing of the state in which the applicant wishes to be registered.

and are capable of providing nursing care at a beginning level in hospitals, nursing homes, doctors' offices, clinics, and selected community agencies.

The Ohio House Bill 327 requires a criminal records check for new applicants for licensure and for individuals from another state endorsing as an RN into Ohio. Candidates who wish to sit for the NCLEX RN examination will be required to submit their fingerprints to the Bureau of Criminal Identification and Investigation (BC&I) to process the BCI&I civilian fingerprint card and the FBI applicant fingerprint card for identification and criminal background verification. This requirement becomes effective for all students entering a pre-licensure program after June 1, 2003.

Accreditation

The program is fully approved by the Ohio Board of Nursing and accredited by the National League for Nursing Accrediting Commission.

Admission Requirements

Admission is determined on a competitive basis. The total number of students admitted to the program is based upon available facilities and faculty. Qualified applicants are admitted to the associate degree in nursing program annually for the fall quarter; however, students may be required to complete designated courses the summer prior to the fall of official admission. Qualified applicants are selected February 1, and selection continues until all spaces in the class are filled.

Criteria for admission:

- **If less than 30 hours of college credit** —
 - Official high school transcript or GED test score transcript (along with partial high school transcript) showing a C or above in algebra, biology, and chemistry.
 - A GPA of 2.0 or higher in high school and college credit.
 - A score of 18 or above in all sections of the ACT.
 - An autobiography form.
 - Shawnee State ENGL placement score or transfer credit equivalent to ENGL 111S.
 - Shawnee State MATH placement score or transfer credit equivalent to MATH 130.
 - Students with an overall ACT score of 23 or better and no category below 18 are eligible for automatic acceptance into the associate

degree nursing program provided they meet the February 1 deadline for application.

Admission after February 1 for these students is possible though not guaranteed.

■ If 30 hours of college credit —

Preference given to students who have successfully completed selected science courses.

- Official high school transcript and official transcripts from all colleges attended.
- College or high school algebra, biology, and chemistry with a C or better.
- A grade point average (GPA) of 2.5 or above on a 4.0 scale.
- An autobiography form.

Program Requirements

The Department of Nursing considers a grade of C (2.0) as the minimum passing grade for all required nursing and non-nursing courses. Courses graded with less than a C will result in academic dismissal from the program. Readmission to the program is determined by the Department of Nursing policies as printed in the current Department of Nursing *Student Handbook*.

Current CPR Healthcare Provider certification; a TB skin test; current immunizations, including Hepatitis B; a recent physical exam; student liability insurance; and health insurance are required and verified prior to enrollment in clinical nursing courses. Verification of these requirements is necessary each year.

A standardized exit examination is required in ADN 283. **A student must satisfactorily pass this examination in order to graduate.** A special fee may be charged for this examination.

ADN program graduation requirements include completion of 105 credit hours as specified in the following program of study (excluding credits and grades from developmental courses). **Students are responsible for verifying they have met degree requirements for graduation.**

Program of Study

All courses must be completed in this sequence during or before the quarter shown.

Course No.	Course	Class Hrs.	Lab ¹ Hrs.	Credit Hrs.
SUMMER QUARTER				
AHNR 135	Health & Wellness (Su or F)	3	0	3
ENGL 111S	Discourse & Comp. (Su or F)	4	0	4
	Totals	7	0	7

¹ Lab/clinical hours: 1 credit hour = 3 lab/clinical hours

Course No.	Course	Class Hrs.	Lab ¹ Hrs.	Credit Hrs.
FALL QUARTER				
ADNR 114	Introduction to Nursing	2	0	2
ADNR 181	Fundamentals I	4.5	7.5	7
BIOL 130	Anatomy & Physiology 1	4	3	5
	Totals	10.5	10.5	14
WINTER QUARTER				
ADNR 182	Fundamentals 2	4	9	7
BIOL 131	Anatomy & Physiology 2	4	3	5
PSYC 101	Introduction to Psychology	4	0	4
	Totals	12	12	16
SPRING QUARTER				
ADNR 193	Adults & Children 1	3	9	6
CHEM 121	Introduction to Chemistry	3	3	4
PSYC 151	Human Growth & Dev.	4	0	4
	Totals	10	12	14
SUMMER QUARTER				
BIOL 350	Microbiology	4	3	5
ENGL 112S	Comp. & Rsrch. (Su or F)	4	0	4
	Totals	8	3	9
FALL QUARTER				
ADNR 203	Adults & Children 2	4	9	7
ADNR 224	Current Issues (F or W)	2	0	2
ADNR 251	Childbearing Families (F or W)	3	6	5
	Totals	9	15	14
WINTER QUARTER				
ADNR 204	Adults & Children 3	4	9	7
ADNR 252	Mental Health (F or W)	3	6	5
SOCI 101	Introduction to Sociology	4	0	4
	Totals	11	15	16
SPRING QUARTER				
ADNR 283	Coordination of Care	4	12	8
	Approved Elective ²	8	0	4
	Totals	12	12	12

LPN-RN: Advanced Placement for LPNs

LPNs may receive advanced placement into the spring quarter of the first year of the associate degree program by successful completion (grade of C or better) of the following courses:

ADNR 197	Transition to Registered Nursing
BIOL 130	Principles of Anatomy & Physiology 1
BIOL 131	Principles of Anatomy & Physiology 2
ENGL 111S	Discourse & Composition
PSYC 101	Introduction to Psychology

Criteria for admission: Valid, active, non-restricted LPN license. For more information, please contact the Department of Nursing.

¹ Lab/clinical hours: 1 credit hour = 3 lab/clinical hours

² Elective must be approved by the Department of Nursing.

Dental Hygiene

Dental hygiene is a vital health service component of dentistry and emphasizes oral health and the prevention of oral disease.

Most dental hygienists are employed in private dental offices and work under the supervision of a dentist. The hygienist's main function is to provide dental health education, home care instruction, and diet/nutritional counseling. Dental hygiene services include performing oral prophylaxis, scaling and polishing of the patient's teeth to remove soft and hard deposits; dental charting and oral examinations; exposing and processing radiographs; applying fluoride treatments and sealants; and making preliminary impressions for study models.

A dental hygienist should possess fine-motor skills and eye-hand coordination. Dental hygienists should be able to effectively communicate with individuals, both one-on-one and during small group interactions.

Accreditation

The dental hygiene program is accredited by the American Dental Association—Commission on Dental Accreditation.

Dental Hygiene Program Goals

- Graduates of the dental hygiene program will be knowledgeable in the basic sciences which support dental hygiene.
- Graduates will be able to assume responsibility for providing current and complete dental hygiene services, including assessment of the patient's physical and oral conditions, and demonstrate preparation for medical/dental emergencies.
- Graduates will participate in dental hygiene continuing education and community service and become knowledgeable in scientific advancements and innovations in the profession.

Job Opportunities

Hygienists are employed in the following areas:

- **Private Practice**
- **Public Health** Dental hygienists may be involved in school-based oral screening or

sealant programs, planning, implementing, and evaluating oral health education programs for dental professionals, medical professionals, and the public.

- **Dental Marketing** Employment opportunities may be available with companies that market dental-related materials and equipment.
- **Hospitals and Clinics** Concerned primarily with the special oral health problems of the bedridden and chronically ill.
- **Teaching and Research** Hygienists with advanced degrees may be employed in research or may teach in dental hygiene educational programs that help students to prepare for the profession.

Academic Requirements

In order to remain in good academic standing in the dental hygiene program, you must:

- Maintain a cumulative GPA of 2.0 in all coursework needed to meet the requirements for an associate of applied science degree in dental hygiene. This applies to all required courses taken before as well as after admission into the dental hygiene program.
- Maintain a cumulative GPA of 2.0 in all dental hygiene courses.
- Not receive a failing grade in any of the required courses for the dental hygiene program.

Students who fail to achieve any one of the three requirements for good academic standing will be dismissed from the dental hygiene program with the option of reapplying for admission the following academic year. The decision to readmit a student will be made by the dental hygiene faculty after reviewing the student's progress in completing any conditions for readmittance as stated in the letter of dismissal and an interview with the student. Students who are academically dismissed from the dental hygiene program for a second time are not eligible for readmittance.

Students may appeal a dismissal from the dental hygiene program by following the guidelines for appeal as detailed in this catalog.

Please Note

- After the first quarter, all subsequent basic and technical courses are closely related and, therefore, must be taken in sequential order.
- Only those students who have been officially accepted into the program or who have received the approval of the department's chairperson may take the courses beginning with the DTHY prefix.

Sample Schedule

Course No.	Course	Class Hrs.	Lab Hrs.	Credit Hrs.
FIRST QUARTER				
AHNR 103	Prin. of Medical Science	3	0	3
BIOL 101	Introduction to Biology	3	0	3
DTHY 111	Oral Anatomy 1	3	0	3
DTHY 121	Clinical Dental Hygiene 1	2	6	4
	Totals	11	6	13
SECOND QUARTER				
BIOL 162	Human Anat./Phys.	4	3	5
DTHY 101	Radiology 1	2	0	2
DTHY 102	Oral Histology/Embryo	2	0	2
DTHY 112	Oral Anatomy 2	2	0	2
DTHY 122	Clinical Dental Hygiene 2	2	6	4
	Totals	12	9	15
THIRD QUARTER				
DTHY 113	Radiology 2	1	3	2
DTHY 123	Clinical Dental Hygiene 3	2	8	5
DTHY 202	Periodontics	3	0	3
DTHY 220	Oral Microbiol./Immun.	3	0	3
	English/Human./Social Sc.	4	0	4
	Totals	13	11	17
FOURTH QUARTER (Summer)				
DTHY 203	Dental Materials	2	3	3
DTHY 205	Dental Health Education	3	0	3
DTHY 224	Clin. D. H. 4/Off. Emerg.	2	9	5
DTHY 290	Sem./Adv. Periodontics	1-3	0	1-3
	Totals	8-10	12	12-14
FIFTH QUARTER				
DTHY 103	Human Nutrition	3	0	3
DTHY 201	Gen. and Oral Pathology	3	0	3
DTHY 225	Clin. D. H. 5/Spec. Needs	1	12	5
	English/Human./Social Sc.	4	0	4
	Totals	11	12	15
SIXTH QUARTER				
DTHY 204	Pharmacology	3	0	3
DTHY 206	Public Health	3	0	3
DTHY 226	Clin. D.H. 6/Prv. Dnt. & Jrs.	1	12	5
	English/Human./Social Sc.	4	0	4
	Totals	11	12	15
SEVENTH QUARTER				
DTHY 227	Clin. D.H. 7/Career Mgr.	1	9	4
	English/Human./Social Sc.	7	0	7
	Elective	3	0	3
	Totals	11	9	14

¹ English/Humanities/Social Science Requirements: ENGL 111S, ENGL 112S, PSYC 101, SPCH 103, SOCI 101.

² 3-Credit Hour Elective: Any English, psychology, speech, or sociology course with a catalog number higher than the required courses listed above. Any business management, personnel management, or computer course.

Emergency Medical Technology

Emergency medical technicians are health care professionals who provide emergency treatment to patients in the prehospital environment. They are familiar and comforting figures at the scene of an accident or medical emergency, where their special skills often mean the difference between life and death.

Careers in prehospital care are challenging and exciting. They require students who possess leadership skills, are good decision makers, can remain calm in emergency situations, and who are compassionate and caring.

Emergency medical technicians work directly with physicians in correlating and providing care to patients experiencing illness or injury.

Several levels of training are available at Shawnee State for emergency medical technicians. The entry level for the profession is the **Emergency Medical Technician - Basic (EMT-B)**. Education for this level of emergency care is the 130-hour Emergency Victim Care Course (EMTP 110).

The **Intermediate Emergency Medical Technician - (EMT-I)** provides emergency care at a high level, utilizing advanced skills in airway and shock management. Educational preparation for the intermediate EMT is included in EMTP 210 through 212.

The **Emergency Medical Technician - Paramedic (EMT-P)** is the highest level of certified emergency care provider. The paramedic receives education in a program of study encompassing seven courses in addition to the EMT-A and advanced EMT-A courses (EMTP 210 through 241). This education includes classroom and laboratory instruction, as well as hospital and field clinical experiences.

An exciting opportunity exists for EMT-P students at Shawnee State. Students can pursue the associate of applied science degree in emergency medical technology. This two-year program is intended to expand the knowledge and experience base of the EMT-Paramedic in both general academics and prehospital emergency medicine. Completion of this program prepares the paramedic student for supervisory positions, advanced clinical procedures, as well as teaching opportunities in EMS. This degree may be pursued as part of the initial educational experience or for career advancement.

Certification

Upon successful completion of:

- **EMTP 110:** Students are eligible to sit for the Basic National Registry Exam. Upon successful completion of the exam, the student receives Ohio and National Registry certification as an EMT-Basic.
- **EMTP 210-212:** Students are eligible to sit for the Intermediate National Registry Exam. Upon successful completion of the exam, the student receives Ohio and National Registry certification as an Intermediate EMT.
- **EMTP 210-242:** Students are eligible to sit for the Paramedic National Registry Exam. Upon successful completion of the exam, the student receives Ohio and National Registry certification as a Paramedic (EMT-P). Upon completion of the two-year program, the student receives the associate of applied science degree.

Accreditation

The EMT-B and paramedic training programs have received accreditation from the Ohio Department of Public Safety, Division of Emergency Medical Services.

Employment Opportunities

Positions for emergency medical technicians are available in private ambulance companies, hospitals, industry, fire departments, 911 dispatch offices, and the armed forces. Law enforcement agencies, park services, ski patrols, and other groups train their personnel to become EMT-Bs or paramedics as part of their duties.

Academic Requirements

In order to remain in good academic standing in the emergency medical technology program, you must:

1. Maintain a grade point average of 2.0 in all coursework needed to meet the requirements for an associate of applied science degree in emergency medical technology. This applies to all required courses taken before, as well as after, admission in the emergency medical program.
2. Maintain a grade point average of 2.0 in all emergency medical technology courses.

- Not receive a failing grade in any of the required courses for the emergency medical technology program.

Students who fail to achieve any one of the three requirements for good academic standing will be dismissed from the emergency medical technology program with the option of reapplying for admission the following year. You may appeal a dismissal from the emergency medical technology program by following the guidelines for appeal as detailed in this catalog.

Please Note

- After the first quarter, all subsequent basic and technical courses are closely related and, therefore, must be taken in sequential order.
- Only those students who have been officially accepted into the program or who have received the approval of the department's director may take the courses beginning with the EMTP prefix, except EMTP 101 and 102.

Entrance Requirements

EMT-B Course (EMTP 110)

- Minimum of 18 years of age
- High school diploma or equivalent
- Current, unconditional driver's license
- Completed Pre-Entrance Medical Record with recent TB and Tetanus
- Evidence that you have not been convicted of, pled guilty to, or had a judicial finding of guilt for any of the following: fraud or material deception in applying for or obtaining a certificate to practice; any of the following felonies: murder, aggravated murder, voluntary manslaughter, felonious assault, kidnapping, rape, sexual battery, gross sexual imposition, aggravated arson, aggravated robbery, aggravated burglary; a misdemeanor, other than a traffic violation committed in the course of practice; a misdemeanor involving moral turpitude; a violation of any federal, state, county, or municipal narcotics law; any act committed in another state, that, if committed in Ohio, would constitute a violation set forth in 4765-8-01 (A) (3) (b) of the Ohio Administrative Code.

Advanced EMT-A Course (EMTP 210, EMTP 211, EMTP 212)

All EMT-B requirements, and:

- Completed University application
- Current Ohio EMT-A certification
- Evidence of not less than six months' experience providing prehospital care in the prehospital setting
- Letter of recommendation from a supervisor of the emergency medical service with which the above requirement was met
- Conference with the director of the department, showing evidence of maturity, good judgement, and good moral character
- Completion of an examination which addresses aptitude in reading, writing, and mathematics skills. Remedial education in deficient areas may be required. Paramedic Program (EMTP 210 through 242) All EMT-A requirements, and:
- Successful completion of the national registry of EMT's basic or intermediate level examination
- Must have BIOL 162 or higher anatomy and physiology course as a pre- or corequisite (example: EMTP 295 Anatomy & Physiology for EMS).

**Associate of Applied Science
Emergency Medical Technology
Curriculum**

Course No.	Course	Class Hrs.	Lab Hrs.	Credit Hrs.
FIRST QUARTER				
AHNR 102	Medical Terminology	2	0	2
BIOL 101	Introduction to Biology	3	0	3
EMTP 102	Cardiopulm. Resuscitation	1	0	1
EMTP 110	Emergency Victim Care	9	3	10
	Totals	15	3	16
SECOND QUARTER				
EMTP 120	EMS Systems	3	0	3
ENGL 111S	Discourse & Composition	4	0	4
PSYC 101	Introduction to Psychology	4	0	4
SPCH 103	Pub. Spk. & Hum. Com.	3	0	3
	Totals	14	0	14
THIRD QUARTER				
BUAI 101	Computer Applications 1	4	0	4
EMTP 130	Major Incident Response	2	0	2
ENGL 112S	Composition & Research	4	0	4
SOCI 101	Introduction to Sociology	4	0	4
	Totals	14	0	14
FOURTH QUARTER (optional)				
XXX	General Elective			

Course No.	Course	Class Hrs.	Lab Hrs.	Credit Hrs.
FIFTH QUARTER				
EMTP 210	Paramedic Skills 1	5	0	5
EMTP 211	Paramedic Skills 1 Lab	0	2	1
EMTP 212	Paramedic Skills 1 Clinical	0	4	1
EMTP 220	Paramedic Skills 2	3	2	3
XXX	General Elective	4-5	0	4-5
	Totals	12-13	8	14-15
SIXTH QUARTER				
EMTP 230	Paramedic Skills 3	8	0	8
EMTP 231	Paramedic Skills 3 Lab	0	3	1
EMTP 232	Paramedic Skills 3 Clinical	0	4	1
XXX	EMS Elective	1-4	0	1-4
XXX	General Elective	4-5	0	4-5
	Totals	13-17	7	15-19
SEVENTH QUARTER				
EMTP 240	Paramedic Skills 4	8	0	8
EMTP 241	Paramedic Skills 4 Lab	0	3	1
EMTP 242	Paramedic Skills 4 Clinical	0	4	1
EMTP 250	Adv. Emergency Procedures	2	2	3
XXX	General Elective	4-5	0	4-5
	Totals	14-15	9	17-18

Approved Electives (To total 23 to 37 credits)

Choose at least two of the following:

AHNR 312	Health Care Personnel Management	4
BIOL 151	Principles of Biology	5
BIOL 162	Human Anatomy & Physiology	5
BIOL 310	Principles of Anatomy	5
BIOL 320	Principles of Physiology	3
BIOL 321	Human Physiology Lab	2
BIOL 350	Microbiology	5
ENGL 115S	Composition & Literature	4
MATH 110S	Mathematics Core Course	4
SOSC 110S	Foundations of Social Science	4

Choose at least two of the following:

BUMG 210	Management Concepts	4
BUMG 235	Personnel Management	4
ECON 101	Principles of Economics	4
PSYC 151	Human Growth & Development	4
PSYC 405	Death & Dying	4

Technical Electives

EMTP 212	Advanced EMT Defibrillation	4
EMTP 260	EMS Field Studies	3
EMTP 270	EMS Management	3
EMTP 295	Special Topics in EMS	1-4

Medical Laboratory Technology

Medical laboratory technology is a profession which combines the challenges and rewards of medicine and science. Billions of laboratory procedures are ordered by physicians and performed by certified laboratory technicians and technologists. They range from simple pregnancy testing to more complex procedures for detecting such diseases as diabetes, anemia, and cancer. Medical laboratory technology is concerned with the accurate

performance of these tests to determine the absence, presence, extent, and causes of disease.

Graduates of this nationally accredited, two-year associate degree program are eligible to be certified by nationally-recognized certification agencies. They work under the supervision of a pathologist or technologist/laboratory scientist and are qualified to perform a wide array of analytical tests in the areas of hematology, microbiology, chemistry, blood banking, coagulation, serology, and urinalysis. MLTs may work in community hospital laboratories, as well as private, industrial, and reference laboratories. Physician's office laboratories, state and federal agencies, and the military are also sources of employment for certified medical laboratory technicians.

The curriculum consists of seven continuous quarters of general education, basic science, and clinical laboratory science coursework, including an 18-week internship in an affiliated hospital.

The number of individuals accepted into the program will not exceed the number of approved clinical affiliation sites.

Certification

Upon successful completion of this program, graduates are awarded the associate of applied science degree and are eligible to become nationally certified by the American Society of Clinical Pathologists (ASCP) and/or the National Credentialing Agency for Medical Laboratory Personnel (NCA) as a medical laboratory technician.

Accreditation

The MLT program is nationally accredited and recognized by the National Accrediting Agency for Clinical Laboratory Sciences (NAACLS), 8410 West Bryn Ave., Suite 670, Chicago, IL 60631-3415, phone: 773.714.8880.

Employment Opportunities

Health care continues to be one of the fastest growing service industries in the United States. Employment opportunities are generally available within our geographical area as well as throughout the United States.

Scholarships

The Skitarelic-Swanson Family Medical Laboratory Science Scholarship was established in 1997 to recognize a medical laboratory science

student for outstanding aptitude, performance, and enthusiasm as well as need. The applicant must be entering the second year of the MLT program.

Applications should be made on the traditional Shawnee State scholarship form. The student selected will be judged based on their didactic and skill-based performances as well as their affective professional behaviors as determined by a committee of MLS faculty, the College of Professional Studies' dean, and an appointed Southern Ohio Medical Center-based laboratory professional.

The recipient of the award must be a full-time student at Shawnee State University in good academic standing. They will receive the award in increments of 1/3 to cover three academic quarters.

Academic Requirements

Eligibility for clinical practicum, as well as continuation in the MLT program, requires that students:

- Achieve a grade of C or better in the lab and lecture portions of all MLTC courses.
- Achieve a passing grade in all non-MLTC courses.
- Maintain a grade point average of 2.5 or above in all MLT required courses.

Application to the Program

See the Associate Degree Admission Requirements on page 149. Students applying to the MLT program with math and English ACT scores less than 22 must take the Shawnee State placement examination if they have not completed mathematics and English courses at the college level. Students are also required to make an appointment with the MLT chairperson (740.351.3388) for a conference once they are notified that application to the MLT program is complete. All application materials must reach the admission office by April 1 to be considered for the first round of admissions to the MLT program. Others will be considered on a space available basis after April 1.

Health and Physical Ability Requirements

There are specific health and physical ability requirements for the medical laboratory technology program. This information is provided at the time of application to the program.

Please Note

Registration for courses with the MLTC prefix requires admission to the MLT program and/or the approval/signature of the MLT chairperson. Only those students who have been officially accepted or named as an alternate in the program may register for courses beginning with the MLTC prefix.

Sample Schedule

Course No.	Course	Class Hrs.	Lab Hrs.	Credit Hrs.
FIRST QUARTER				
BIOL 151	Principles of Biology	4	2	5
CHEM 141	General Chemistry 1 OR	4	3	5
CHEM 121	Intro. to Gen. Chemistry 1	3	3	4
MATH 130	Intermediate Algebra	4	0	4
MLTC 111	Medical Tech. Orientation	2	0	2
	Totals	13-14	5	15-16
SECOND QUARTER				
BIOL 162	Human Anatomy & Phys.	4	2	5
CHEM 142	General Chemistry 2 OR	4	3	5
CHEM 122	Intro. to Gen. Chemistry 2	3	3	4
MATH 131	College Algebra	4	0	4
MLTC 112	Basic Laboratory Skills	2	3	3
	Totals	13-14	8	16-17
THIRD QUARTER				
CHEM 143	General Chemistry 3 OR	4	3	5
CHEM 200	Intro. to Organic Chemistry	3	3	4
ENGL 111S	Discourse & Composition	4	0	4
MLTC 209	Hematology 1	2	6	4
MLTC 210	Hemostasis	2	2	2
MLTC 212	Clinical Chemistry 1	2	6	4
	Totals	13-14	17	18-19
FOURTH QUARTER				
BIOL 350	Microbiology	4	3	5
MLTC 202	Immunoserology	2	3	3
MLTC 211	Hematology 2	2	3	3
MLTC 213	Clinical Chemistry 2	2	3	3
	Totals	10	12	14
FIFTH QUARTER				
CHEM 305	Organic Chemistry 1 <i>No chemistry is required if CHEM 200 has been taken.</i>	3	3	4
MLTC 201	Urinalysis	2	3	3
MLTC 203	Blood Banking 1	2	6	4
MLTC 204	Parasitology	1	2	1
MLTC 207	Clinical Microbiology	3	6	5
	Totals	11	20	17
SIXTH QUARTER				
ENGL 112S	Composition & Research	4	0	4
MLTC 215	Laboratory Simulation	0	6	3
MLTC 216	Medical Technology Seminar	1	0	1
MLTC 217	Case Studies	1	0	1
MLTC 220	Clinical Practicum	0	20	4
	Totals	6	26	13
SEVENTH QUARTER				
MLTC 221	Clinical Practicum 2	0	40	8
MLTC 225	Special Problems in Med. Lab.	2	0	2
SOCI 101	Introduction to Sociology	4	0	4
SPCH 103	Public Speaking	3	0	3
	Totals	9	40	17

Occupational Therapy Assistant

Occupational therapy is a vital health care service that uses “occupation,” meaning purposeful activity, as the basis for treatment of people with a wide variety of physical, developmental, and emotional disabilities.

Occupational therapists and occupational therapy assistants help disabled people of all ages acquire or regain the skills they need to live independent, productive, and satisfying lives. They work in hospitals, rehabilitation centers, nursing homes, public and private schools, and home health agencies.

Occupational therapy assistants work under the guidance of occupational therapists. They may choose or construct equipment that helps people to function more independently; they may carry out treatment activities for individuals or groups of patients; and they work closely with families of patients who are preparing to return home.

To become an occupational therapy assistant, you must complete an educational program. The majority of these are two-year associate degree programs like the one at Shawnee State University. Studies include basic academic subjects, human growth and development, the functioning of the human body, and occupational therapy principles and techniques. The OTA program requires two, eight-week rotations of supervised practical experience in a variety of health care settings.

After successfully completing the educational program, you are eligible to take the national certification examination for the occupational therapy assistant. Many states, including Ohio, Kentucky, and West Virginia, also require licensing by their respective states to practice occupational therapy.

Accreditation

The occupational therapy assistant program is accredited by the Accreditation Council for Occupational Therapy Education (ACOTE) of the American Occupational Therapy Association (AOTA), located at 4720 Montgomery Lane, P.O. Box 31220, Bethesda, MD 20824-1220. AOTA's phone number is (301) 652-AOTA. Graduates of the program are able to sit for the national certification examination for the occupational therapy assistant administered by the National Board for Certification in Occupational Therapy, Inc. (NBCOT); however, the NBCOT sets its own criteria for taking the exam, which may include questions on the applicant's criminal history. For

more information on these limitations, you can contact NBCOT at 301.990.7979. After successful completion of this exam, you are a certified occupational therapy assistant (COTA). Most states require licensure in order to practice; however, state licenses are usually based on the results of the NBCOT Certification Examination.

Academic Requirements

To remain enrolled in the occupational therapy assistant program, you must:

- Not receive below a “C” in any course with the OTAT prefix.
- Maintain a 2.00 GPA in all courses with the OTAT prefix.
- Obtain an overall GPA of no less than 2.00 prior to the third quarter (spring) of the first year.
- Maintain at least a 2.00 GPA during each remaining quarter.
- Successfully complete (with a grade of D- or higher) BIOL 130 and 131 by the end of the third quarter (spring) of the first year.

If *any* of these criteria are not met, you are dismissed from the OTA program. Conditions for readmission to the OTA program are specified by the chairperson of the department at the time of dismissal.

Clinical Requirements

Clinical placements for the OTA program in the Portsmouth area are limited. OTAT 108, 204, and 208 (Fieldwork 1) are clinical courses requiring six to seven hours, one day per week at the assigned facility. These placements may be up to, and sometimes at distances greater than, 70 miles away from Shawnee State University. You are responsible for your own transportation to and from these facilities.

OTAT 220 and 221 (Fieldwork 2) consist of two rotations of eight weeks each. You are required to be at that facility during normal working hours (usually 40 hours per week). The OTA program assigns each student two placements. You are responsible for all expenses incurred to complete the Fieldwork 2 requirements of the OTA program. Requirements for graduation and to remain in the program are listed in the OTA *Student Handbook*.

You are required to have successfully completed all OTAT and other courses in the curriculum (as indicated by a minimum 2.00 GPA) prior to participating in OTAT 220 and 221. OTAT 220

and 221 must be completed 18 months following completion of other OTA courses and 2 months prior to the NCBOT certification examination date.

Sample Schedule

Course No.	Course	Class Hrs.	Lab Hrs.	Credit Hrs.
FIRST QUARTER (Fall)				
AHNR 102	Medical Terminology	2	0	2
ARTS 231	Ceramics 1	4	0	4
BIOL 130	Prin. of Anatomy & Phys. 1	4	2	5
BUIS 101 ¹	Intro. to Comp. Info. Syst.	4	0	4
PSYC 101	Introduction to Psychology	4	0	4
	Totals	18	2	19
SECOND QUARTER (Winter)				
BIOL 131	Prin. of Anatomy & Phys. 2	4	3	5
OTAT 101	Intro. to Occup. Therapy	3	3	4
OTAT 102	Therapeutic Media 1	1	6	3
OTAT 108	Practicum 1 (FW1)	1	6	2
PSYC 151	Human Growth & Devel.	4	0	4
	Totals	13	18	18
THIRD QUARTER (Spring)				
ENGL 111S	Discourse & Composition	4	0	4
OTAT 103	Disease Pathology	4	0	4
OTAT 109	Applied Anatomy & Kines.	1	3	2
OTAT 110	Group Dynamics	1	3	2
SOCI 101	Introduction to Sociology	4	0	4
	Totals	14	6	16
FOURTH QUARTER (Summer)				
ENGL 112S	Composition & Research	4	0	4
OTAT 205	Therapeutic Media 2	1	6	3
OTAT 210	OTA in Physical Dysfunction	4	4	5
OTAT 299	Special Topics	2	0	2
	Totals	11	10	14
FIFTH QUARTER (Fall)				
OTAT 204	Practicum 2 (FW1)	2	6	3
OTAT 206	Contemp. Media in OT	1	3	2
OTAT 212	OTA in Mental Health	3	3	4
PSYC/SOCI	Elective	4	0	4
SPCH 103	Public Spk. & Hum. Com.	3	0	3
	Totals	13	12	16
SIXTH QUARTER (Winter)				
EMTP 101 ²	First Aid & CPR	2	0	2
OTAT 203	OTA in Devel. Disabilities	4	3	5
OTAT 208	Practicum 3 (FW1)	2	6	3
OTAT 209	OTA in Geriat. Prog. Plan.	3	3	4
OTAT 211	OTA Seminar	2	0	2
	Totals	13	12	16
SEVENTH QUARTER (Spring)				
OTAT 220	Clinical Application (FW2)	0	40	8
OTAT 221	Clinical Application (FW2)	0	40	8
	Totals	0	80	16

Physical Therapist Assistant

Within the discipline of physical therapy, the position of physical therapist assistant (PTA) has emerged as an integral, skilled clinician. The PTA plays a key role in the patient's recovery from injury or dysfunction, as well as in the client's pursuit of optimal fitness and health promotion. PTAs may intervene in the plan of care established by the physical therapist, treating impairments, functional limitations, and disabilities which may arise across the human lifespan, as these affect the cardiovascular and neuromusculoskeletal systems of the body.

Philosophy

The physical therapist assistant (PTA) is a generalist who works under the supervision and guidance of the physical therapist (PT). Specifically, the PTA follows the APTA Code of Ethics and the appropriate state rules and regulations in a professional manner. The PTA is technically competent, safe, and knowledgeable with the aim of being a reflective lifelong learner, so as to assure career development to the fullest potential. Furthermore, the PTA is the only formally trained skilled practitioner who works under the physical therapist's supervision and direction. The PTA appropriately delegates within his or her scope of practice. The PTA is a frontline patient/client and family educator and psychosocial supporter, operating under the PT plan of care.

Educational Process

The faculty is committed to providing a coordinated curriculum based upon a broad spectrum of research, theory, function, and life skills. Professionalism is role modeled by primary didactic faculty and clinical instructors. They train and educate the PTA to communicate in ways that are congruent and appropriate within the program, clinical environment, and community. A keystone to the educational process is the ability to critically think and use sound judgment. Not only do trained PTAs act as educators but also as

¹ Due to the high demand for BUIS 101, you are strongly encouraged to take this course early in the program..

² Students must have current first aid and CPR certificates prior to starting clinical application (OTAT 220 and 221) spring quarter. This may be obtained either through EMTP 101, 102, SSAT 227 (for CPR only), or at another agency.

patient/client advocates, linking community resources to patient/client needs. Clinical data collection skills are taught using standardized tests, as are consistent with the Normative Model of PTA Education and the Clinical Performance Instrument (CPI). Students are evaluated on an ongoing basis to assure technical competencies and procedural knowledge required to complete all of the performance indicators with regards to safety and to pass the state/national licensure examination. In the state of Ohio, a license is required to practice or teach as a PTA.

Employment

PTAs use electrical, mechanical a-thermal and thermal modalities; assist in gait training; instruct in strengthening, balance and coordination exercises; and improve work or sports performance and activities of daily living skills.

PTAs work in a variety of settings, including hospitals, rehabilitative centers, skilled nursing facilities, outpatient ambulatory care centers, home health agencies, federal or state agencies, and within school settings. Future prospects appear bright for the next five years in terms of new positions, from the latest government and labor demand surveys.

The curriculum is designed in a consecutive, seven-quarter sequence, incorporating both academic and clinical education. Upon successful completion of the program, the student is awarded an associate of applied science degree. The successful graduate is eligible to apply for the National PTA Exam, given on a state-by-state basis. Prospective students are encouraged to review the Essential Functions of the PTA, as found on the SSU web page (www.shawnee.edu) or within the application packet. Interested students with a background of felony convictions are advised to contact the State of Ohio PT Section and Licensing Board (1.800.871.1921) prior to application to assure that he or she will be eligible to obtain licensing in the future.

Application Information

As with any health sciences program at Shawnee State University, prospective students are required to progress through a special selection process, in addition to becoming accepted by the University at large. This process is initiated by contacting the health sciences representative within the Office of

Admission. The deadline and special packet vary from year to year, so students are encouraged to request the most recent information. A new group of students begins study each fall quarter. A limited number of seats are available per year, so students are advised to apply early in the spring.

Academic Requirements

In order to remain in good standing in the PTA program, and subsequently graduate, students must obtain a minimum of a C (2.0) in each course within the curriculum. For students not maintaining this performance standard in PTA core courses, a delayed re-entry is available at the faculty's discretion.

Accreditation

The Commission on Accreditation of Physical Therapy Education (CAPTE) accredits the PTA program at Shawnee State University. At the time of this writing, the program is accredited, having submitted its intent to become re-accredited. For more information, contact CAPTE at: 1111 N. Fairfax Street, Alexandria, VA 22314 or phone 1.703.684.2782. The web site is www.accreditation@apta.org.

Please Note

- Clinical practicums are contracted with training sites throughout the United States. Most clinical sites are within a 30-60 minute drive of SSU. The faculty highly recommends that students participate at least once in a clinical practicum that is two or more hours away from campus. Students may request that the faculty originate a new site if it meets the criteria and needs of the program.
- Only those students who have been officially accepted into the program or who have received approval by the program director or dean are eligible to take any courses beginning with the PTAT prefix.

Curriculum

This program is designed over the following seven-quarter sequence:

Course No.	Course	Class Hours	Lab Hours	Credit Hours
FIRST QUARTER (Fall 1)				
AHNR 102	Medical Terminology	2	0	2
AHNR 104 ¹	Phys. Prin. for Health Sci.	3	0	3
BIOL 130	Anatomy & Physiology 1	4	2	5
ENGL 111S	Discourse & Composition	4	0	4
PTAT 111	Principles of PTA	3	0	3
	Totals	16	2	17
SECOND QUARTER (Winter 1)				
BIOL 131	Anatomy & Physiology 2	4	2	5
EMTP 101 ²	First Aid & CPR	2	0	2
PTAT 112	PTA Procedures 1	3	6	5
PTAT 115	PT in Physical Dysfunction	3	0	3
	Totals	12	8	15
THIRD QUARTER (Spring 1)				
BIOL 311	Prin. of Kinesiology	4	0	4
ENGL 112S	Composition & Research	4	0	4
PSYC 101	Introduction to Psychology	4	0	4
PTAT 113	PTA Procedures 2	3	6	5
PTAT 116	Neurology for PT	1	0	1
	Totals	16	6	18
FOURTH QUARTER (Summer)				
PTAT 114	Anatomy & Kinesiology	3	6	5
PTAT 117	Clin. Practicum & Seminar	1	4	2
SOCI 101	Introduction to Sociology	4	0	4
SPCH 103	Public Spk. & Hum. Comm.	3	0	3
	Totals	11	10	14
FIFTH QUARTER (Fall 2)				
PTAT 202	PTA Procedures 3	3	6	5
PTAT 212	Clinical Practicum 1	2	12	4
PTAT 231	Rehab. Procedures 1	3	3	4
PTAT 235	PT Trends & Administration	2	0	2
	Totals	10	21	15
SIXTH QUARTER (Winter 2)				
PSYC 151	Human Growth & Devel.	4	0	4
PTAT 213	Clinical Practicum 2	2	12	4
PTAT 232	Rehab. Procedures 2	3	3	4
	Elective	4	0	4
	Totals	13	15	16
SEVENTH QUARTER (Spring 2)				
PTAT 214	Clinical Practicum 3	0	38	10
PTAT 255	PTA Seminar	2	0	2
	Totals	2	38	12

Radiologic Technology

The radiologic technology curriculum prepares students for careers as radiographers, who work under the supervision of medical radiologists or physicians in hospital radiology departments, clinics, commercial x-ray laboratories, or doctors' offices. The responsibility of the radiographer is to produce a radiographic (x-ray) image of the highest diagnostic quality of any designated area of the

human body. It is from this image that the radiologist makes his or her interpretations.

Curriculum for this program covers eight academic quarters. The first four academic quarters are designed to provide you with mathematics, basic science, general education courses, supporting technical courses, clinical education, and specialized courses in radiography. The second year of the program consists of additional clinical education scheduled in affiliated hospitals along with advanced radiologic technology courses.

Experience in the radiology departments of the affiliated hospitals provides opportunity for the practical application of knowledge learned in the classroom. This experience in the hospital is a vital part of the program, since it enables you to assist in the handling of sick and injured patients as they undergo a wide variety of radiographic examinations.

Upon satisfactory completion of the course requirements, you are awarded the associate in applied science degree and are eligible to apply for examination by the American Registry of Radiologic Technologists.

Accreditation

The radiologic technology program at Shawnee State University is fully accredited by: The Joint Review Committee on Education in Radiologic Technology, 20 N. Wacker Drive, Suite 900, Chicago, IL 60606-2901, phone 312.704.5300.

Academic Requirements

To remain in good standing in the radiologic technology program, the following three conditions must be met:

- You must not receive a grade of F in any of the required courses listed in the eight-quarter sequence.
- You must not receive a grade below a C- in any of the courses with the RDLT prefix.
- You must earn an overall grade point average of 2.0 by the end of the third quarter and maintain it throughout the remainder of the program.

If any one of these three conditions is not met, you are academically dismissed from the radiologic technology program. You may apply for readmission to the radiologic technology program the following year.

¹ PSCI 251 may be substituted for AHNR 104, as available.

² Documented independent agency certifications will waive EMTP 101.

Please Note

- Only those students who have been officially accepted into the program or who have received the approval of the department's chairperson may take the courses beginning with the RDLT prefix.
- After the first quarter, all subsequent technical and science courses are closely related and, therefore, must be taken in sequential order. The basic courses (psychology, speech, etc.) may be taken at your convenience assuming all prerequisites are satisfied.
- You must have a current CPR certification or enroll in EMTP 102.

Sample Schedule

Course No.	Course	Class Hours	Lab Hours	Credit Hours
FIRST QUARTER				
BIOL 101 ¹	Introduction to Biology	3	0	3
MATH 130	Intermediate Algebra	4	0	4
RDLT 101	Radiologic Technology 1	2	6	4
²	Engl./Humanities/Soc. Sc.	4	0	4
	Totals	13	6	15
SECOND QUARTER				
BIOL 310	Human Anatomy	4	3	5
CHEM 121 ¹	Intro. to Gen. Chemistry 1	3	3	4
RDLT 102	Radiologic Technology 2	2	10	4
RDLT 200	Basic Patient Care	3	2	3
	Totals	12	18	16
THIRD QUARTER				
RDLT 103	Radiologic Technology 3	3	2	3
RDLT 111	Radiologic Physics	3	2	4
RDLT 211	Clinical Experience 1	0	16	2
RDLT 312	Sectional Anatomy	2	2	3
²	Engl./Humanities/Soc. Sc.	4	0	4
	Totals	12	22	16
FOURTH QUARTER				
RDLT 104	Radiologic Technology 4	3	2	3
RDLT 212	Clinical Experience 2	0	24	3
	Totals	3	26	6
FIFTH QUARTER				
RDLT 105	Radiologic Technology 5	3	0	3
RDLT 201	Radiographic Exposure	3	2	4
RDLT 213	Clinical Experience 3	0	24	3
²	Engl./Humanities/Soc. Sc.	4	0	4
²	Engl./Humanities/Soc. Sc.	4	0	4
	Totals	14	26	18
SIXTH QUARTER				
RDLT 106	Radiologic Technology 6	3	0	3
RDLT 112	Radiobiol. & Radia. Protect.	3	0	3

RDLT 214	Clinical Experience 4	0	24	3
²	Engl./Humanities/Soc. Sc.	4	0	4
	Totals	10	24	13

SEVENTH QUARTER

RDLT 107	Radiologic Technology 7	3	0	3
RDLT 113	Radiographic Processing	2	0	2
RDLT 215	Clinical Experience 5	0	24	3
²	Engl./Humanities/Soc. Sc.	4	0	4
³	Commun./Leader. Elective	3-4	0	3-4
	Totals	12-13	24	15-16

EIGHTH QUARTER

RDLT 108	Radiologic Technology 8	2	0	2
RDLT 216	Clinical Experience 6	0	32	4
	Totals	2	32	6

Respiratory Therapy

Respiratory therapy is an allied health specialty, whose practitioners are employed, under medical direction, to provide treatment, management, diagnostic evaluation, and care to patients with deficiencies or abnormalities associated with the process of breathing.

Respiratory therapists work side-by-side with physicians, nurses, and other health care team members to treat patients ranging in age from premature infants to the elderly. Their duties vary from the administration of oxygen, humidity, and aerosols and the drainage of lung secretions, to the use of technologically sophisticated monitoring devices and treatment techniques in order to assure the survival of patients with life threatening conditions such as head or chest trauma.

Some practitioners choose to spend the majority of their time working in diagnostic laboratories, where they assist in the evaluation of the type and extent of a patient's pulmonary dysfunction and evaluate the effectiveness of the patient's current therapy. Other practitioners may choose to work in specialized areas of respiratory care, including education, management, home care, sales, research, and specialized areas of diagnostic testing or patient care such as cardiovascular diagnostics or care of infants and children.

Certification

The graduate of the respiratory therapy program is awarded the associate of applied science degree and is eligible to sit for the examinations of the

¹ Students who are planning to pursue a baccalaureate degree may wish to substitute BIOL 151 for BIOL 101 and CHEM 141 for CHEM 121.

² English/Humanities/Social Science Requirements: BUIS 101, ENGL 111S and 112S, PSYC 101, SOCI 101, and SPCH 103

³ 3-4 Credit Hour Communication/Leadership Elective in: Any English, psychology, or sociology course with a catalog number higher than required courses listed above, BUMG 101, 210, 235, 240, or 242.

National Board for Respiratory Care. Successful completion of the “entry-level” examination of the NBRC results in the student being awarded the CRT (Certified Respiratory Therapist) credential. Successful completion also results in graduates being eligible for a license to practice in any state currently having a licensure law. Finally, graduates who successfully complete the “entry-level” examination are also eligible to take the “advanced practitioner” examination of the NBRC. Successful completion of that examination results in the student being awarded the RRT (Registered Respiratory Therapist) credential by the NBRC.

Accreditation

In 1980 the Ohio Board of Regents approved the creation of this program of study, leading to the associate of applied science degree at Shawnee State University. The respiratory therapy program at Shawnee State is fully accredited by the Committee on Accreditation for Respiratory Care and the Commission on Accreditation of Allied Health Education Programs.

Employment Opportunities

Because of the rapid growth of the profession since its inception in the late 1940’s, many medical institutions have found that their need for trained respiratory therapy practitioners has exceeded supply. In addition, many clinics, nursing homes, and home care programs are realizing the potential benefits of having a trained respiratory care practitioner on staff. These needs, coupled with the ever-increasing number of cardiovascular disorders being diagnosed, should continue to assure that individuals who enter this profession will enjoy good career opportunities.

Academic Requirements

To remain in good standing in the respiratory therapy program, the following three conditions must be met:

- You must not receive a grade of F in any of the required courses listed in the curriculum.
- You must not receive a grade below a C- in any course with the RPTT prefix.
- You must earn an overall grade point average of 2.00 by the end of the third quarter and maintain it throughout the remainder of the program.

Failure to meet any one of the three stated conditions may result in dismissal from the respiratory therapy program. You may apply for readmission to the respiratory therapy program the following year, after you have successfully completed the required remedial work as detailed by the chairperson of the department at the time of dismissal.

Application to the Program

See the Associate Degree Admission Requirements on page 149. Students applying to the respiratory therapy program with math and English ACT scores less than 22 must take the Shawnee State placement examination if they have not completed mathematics and English courses at the college level. Students are also required, after their application folder is completed, to make an appointment with the chairperson of the respiratory therapy program, by calling 740.351.3235 or 740.351.3225. This meeting is purely informational and has no bearing on admission decisions. All application materials must reach the admission office by April 1 in order for the applicant to be considered for the respiratory therapy program. Later applications may be considered based on qualifications and space available within the class.

Sample Schedule

Course No.	Course	Class Hrs.	Lab Hrs.	Credit Hrs.
FIRST QUARTER				
AHNR 102	Medical Terminology	2	0	2
BIOL 130	Prin. of Anat. & Phys. 1	4	2	5
RPTT 101	Basic Patient Care	2	3	3
RPTT 102	Card./Renal Anat. & Phys.	5	0	5
	Totals	13	5	15
SECOND QUARTER				
BIOL 131	Prin. of Anat. & Phys. 2	4	2	5
CHEM 121	Intro. to Gen. Chemistry 1	3	3	4
RPTT 110	Medical Gas Therapy	3	3	4
RPTT 115	Clinical Application 1	0	8	1
RPTT 200	Pharmacology	3	0	3
	Totals	13	16	17
THIRD QUARTER				
ENGL 111S	Discourse & Composition	4	0	4
MATH 130	Intermediate Algebra	4	0	4
RPTT 120	Perioperative Care	3	3	4
RPTT 121	Airway Management	1	3	2
RPTT 125	Clinical Application 2	0	8	1
RPTT 131	Pulmonary Function Test.	2	3	3
	Totals	14	17	18
FOURTH QUARTER				
BIOL 350	Microbiology	4	3	5
RPTT 130	Ped. and Neon. Res. Care	4	0	4
RPTT 132	Art. Blood Gas/Acid-Base	1	0	1
RPTT 133	Laboratory Procedures	0	3	1

Course No.	Course	Class Hrs.	Lab Hrs.	Credit Hrs.
RPTT 135	Clinical Application 3	0	16	2
RPTT 202	Pathophysiology	3	0	3
	Totals	12	22	16
FIFTH QUARTER				
ENGL 112S	Composition & Research	4	0	4
RPTT 201	Continuous Mech. Vent.	5	3	6
RPTT 205	Clinical Application 4	0	16	2
¹	General Studies Elective	4	0	4
	Totals	13	19	16
SIXTH QUARTER				
RPTT 210	Critical Care	4	0	4
RPTT 211	Adv. Cardio. Assessment	1	0	1
RPTT 212	Pul. Rehab. & Home Care	1	0	1
RPTT 215	Clinical Application 5	0	24	3
¹	General Studies Elective	4	0	4
SPCH 103	Public Spk. & Hum. Com.	3	0	3
	Totals	13	24	16
SEVENTH QUARTER				
RPTT 220	Seminar	4	0	4
RPTT 225	Clinical Application 6	0	40	8
	Totals	4	40	12

Please Note

- Only those students who have been officially accepted into the respiratory therapy program or have received the approval of the department's chairperson may take courses beginning with the RPTT prefix.
- After the first quarter, all subsequent technical courses are closely related and, therefore, must be taken in sequential order.

¹ General Studies Electives should be selected from the following approved list: ANTH 201 Introduction to Anthropology (4), any English course not currently required greater than ENGL 115S, PHIL 102 Introduction to Logic (4), PSYC 101 Introduction to Psychology (4), SOCI 101 Introduction to Sociology (4). Other communication or social science courses may be accepted, with the approval of the chairperson.



INDUSTRIAL &
ENGINEERING
TECHNOLOGIES

Industrial and Engineering Technologies

You are to be commended if your decision is to attend Shawnee State and to major in an industrial or engineering technology. You will find few things more satisfying than learning about modern technologies. The field of industrial and engineering technology can lead to exciting and professionally fulfilling careers in the 21st Century. The Department:

- Develops curricula that create an understanding of the practical and scientific bases of selected engineering technologies and modifies curricula and teaching methods in response to technological advancement and change.
- Encourages the development of sound work ethics and a spirit of cooperation and excellence.
- Provides cooperative educational services.
- Seeks and encourages participation from the business and industrial community.
- Promotes occupational and educational opportunities for all graduates.

Your professional education is our primary goal, and the quality of your success provides the ultimate evaluation of how well we are meeting our goal.

All of our programs offer career-oriented, technical instruction grounded in a strong base of science and mathematics. If you are interested in these programs, you should prepare yourself by taking mathematics and science courses in high school. If you did not take mathematics and science courses in high school, you are advised to take advantage of the developmental courses available at Shawnee State, preferably during the summer before starting fall quarter. The University administers mathematics and English assessment tests in order to place each student in appropriate courses.

Articulation from Shawnee State's associate degree programs or other colleges' associate degree programs in technology into the junior year of our B.S. programs is possible. If you are interested in this option, you should see your faculty advisor for details.

For More Information

Carl O. Hilgarth, M.S., Chairperson
Cindy Hopkins, Secretary
Dept. of Industrial and Engineering Technologies
Shawnee State University
940 Second Street
Portsmouth, Ohio 45662-4344
Phone: 740.351.3224
Fax: 740.351.3546
E-mail: chopkins@shawnee.edu

Programs in Industrial and Engineering Technologies

Bachelor of Individualized Studies

See page 128 of current catalog for description.

Bachelor of Science

Computer Engineering Technology
Environmental Engineering Technology
Plastics Engineering Technology

Minors

Computer Aided Design
Plastics Engineering Technology

Associate of Applied Science

Optional concentration in robotics available with each degree
Computer Aided Design
Electromechanical Engineering Technology
Plastics Engineering Technology

Associate of Individualized Studies

See page 129 of current catalog for description.

Certificate

Computer Aided Drafting and Design (CADD)
Plastics Engineering Technology
Web Engineering Technology

Industrial and Engineering Technology Programs at Shawnee State

The term "engineering technology" is described by the Accreditation Board for Engineering and Technology as follows:

"Engineering technology is that part of the technological field which requires the application of scientific and engineering knowledge and methods combined with technical skills in support of engineering activities:

it lies in the occupational spectrum between the craftsman and the engineer at the end of the spectrum closest to the engineer.”

This description reflects the common understanding among people in engineering and related professions that the engineering technologist is a distinct type of professional whose main concern and interest is with existing operation, maintenance, and management of products and processes. Technologists are finding increasing acceptance in positions formerly filled by engineers in such fields as sales, manufacturing, field service, and process engineering.

The term “industrial technology” is described by the National Association of Industrial Technology as:

“The field of study designed to prepare technical and/or technical management-oriented professionals for employment in business, industry, and government.”

Industrial technology degree programs and professionals in industrial technology careers typically are involved with the following:

- The application of theories, concepts, and principles found in the humanities and the social and behavioral sciences, including a thorough grounding in communication skills.
- The understanding of the theories and the ability to apply the principles and concepts of mathematics and science and the application of computer fundamentals.
- The application of concepts derived from, and current skills developed in, a variety of technical and related disciplines which may include, but is not limited to, materials and production processes, industrial management and human relations, marketing, communications, electronics, and graphics.
- The completion of a field of specialization, for example, electronic data processing, computer aided design, computer integrated manufacturing, manufacturing, construction, energy, polymers, printing, safety, or transportation.

Students in the B.S. degree programs in engineering technology are required to complete all courses in the University’s general education program. In addition, the Department requires that all B.S. degree candidates take a core curriculum of courses in mathematics, physics, computer programming, and engineering technology sciences.

Pass/No-Credit Policy

Students in the Department of Industrial and Engineering Technologies are not permitted to take any course in their major course of study on a pass/no-credit basis. This includes any course that is specifically identified by course number and/or course title as a requirement for your graduation.

Bachelor Degrees

Bachelor of Science in Computer Engineering Technology

The computer engineering technology program is designed for the student who wishes to pursue a career as a computing professional and who desires a challenging curriculum which offers an holistic approach to computing. Shawnee State’s program maintains a balance between computer software and hardware by blending the most critical courses from computer science with those from electrical engineering technology.

The program also balances computing theory with application by offering rigorous courses, based on the most recent ACM/IEEE computer engineering technology curricula guidelines, and adding to each of these courses an applied lab component. These labs encourage the application of theoretical knowledge to real-world projects which involve software applications, microprocessor-based systems, and computer networks.

The overall breadth and depth of the program prepares graduates to apply computing-based solutions to problems in industry, business, and medicine. In addition, their skills help them expand the frontiers of society by enabling those in the arts and sciences to attain greater levels of achievement in science, literature, art, music, and philosophy through appropriately applied computing technologies.

Careers available to graduates of the computer engineering technology program include:

- Software application developer
- Hardware engineer
- Software engineer
- Local area network specialist
- Data communications specialist
- Digital system designer
- Applied research and development engineer

Degree Requirements

General Education Program (48 Hours) 36 Hours

The General Education Program is composed of 48 credit hours of which 12 hours may be satisfied by the following mathematics and science requirements in the computer engineering technology curriculum. Courses that apply are MATH 131 and Natural Science Option 2: PHYS 211, 212, and 213. Further information about the GEP is listed on page 55 of the current catalog or can be obtained from the department chairperson's office.

Mathematics/Science Courses 28 Hours

Engineering Tech. Mgt. Courses 10 Hours

Electricity and Electronics Courses 16 Hours

Computer Technology Courses 105 Hours

Technical Elective Pairs Comp. 6-8 Hours

Total Hours Required 201-203 Hours

Mathematics/Science Courses (28 Hours)

Course No.	Course	Cr. Hrs.
MATH 131	College Algebra	4
MATH 132	Trigonometry & Analytic Geometry	4
MATH 201	Calculus 1	4
MATH 202	Calculus 2	4
PHYS 211	Calculus-Based Physics 1	4
PHYS 212	Calculus-Based Physics 2	4
PHYS 213	Calculus-Based Physics 3	4

Engineering Technology Management Courses (10 Hours)

ENGL 121	Technical Writing	4
	Electives <i>Select two of the following:</i> <i>ETCO 210, ETCO 225, ETPL 320</i>	6

Electricity and Electronics Courses (16 Hours)

ETEM 111	Electrical Fundamentals 1 (DC)	4
ETEM 112	Electrical Fundamentals 2 (AC)	4
ETEM 121	Electronics 1	4
ETEM 122	Electronics 2	4

Computer Technology Courses (105 Hours)

EETC 101	Computer Engineering Technology	4
EETC 102	Structured Programming 1	4
EETC 103	Structured Programming 2	4
EETC 150	Computer System Integration	4
EETC 200	Assembly Language Programming	4
EETC 201	Object Oriented Programming 1	4
EETC 202	Object Oriented Programming 2	4
EETC 203	Object Oriented Programming 3	4
EETC 216	Algorithms	4
EETC 241	Microprocessor Circuits 1	3
EETC 242	Microprocessor Circuits 2	3
EETC 280	Applied Prog. with Data Structures	4
EETC 316	Automata & Formal Languages	3
EETC 345	Computer Architecture	3
EETC 351	Networking & Communications 1	3
EETC 352	Networking & Communications 2	3
EETC 361	Advanced Circuit Analysis 1	3
EETC 362	Advanced Circuit Analysis 2	3
EETC 371	Operating Systems 1	3

EETC 372	Operating Systems 2	3
EETC 373	Adv. Operating Systems w/UNIX	3
EETC 410	Compiler Design & Implementation	3
EETC 421	Digital Control Systems 1	3
EETC 422	Digital Control Systems 2	3
EETC 430	Database Systems	3
EETC 477	Concurrency	3
EETC 481	User Interface Design & Prog.	3
EETC 483	Software Engineering	3
EETC 491	Design Laboratory 1	4
EETC 492	Design Laboratory 2	4
EETC 495	Topics in Computing	3

Technical Elective Pairs Component (6-8 Hours)

Choose **one** of the pairs below:

PAIR 1: LOGIC

ETEM 211	Electronic Logic Circuits 1	4
ETEM 212	Electronic Logic Circuits 2	4

PAIR 2: ENGINEERING DRAWING

ETCA 101	Introduction to CADD	3
EETG 110	Engineering Drawing 1	3

PAIR 3: WEB ENGINEERING TECHNOLOGY

ETWB 111	XML 1	4
ETWB 112	XML 2	4

PAIR 4: MATHEMATICS ELECTIVES (8 HOURS)

PAIR 5: ADVISOR APPROVED ELECTIVES (6-8 HOURS)

Bachelor of Science in Environmental Engineering Technology

The environmental engineering technology program prepares graduates for responsible operations, maintenance, and management positions in a wide variety of industrial, municipal, recreational, and regulatory corporations or agencies. Those graduates who also earn licensure in a specific division of environmental engineering technologies are better prepared for management/supervisory positions in their environmental specialties.

Graduates of our program have the advantage of understanding the biological, chemical, and physical aspects of environmental engineering, along with the mechanical, electrical, and computer equipment required for waste processing.

The bachelor of science in environmental engineering technology helps the student develop a concern for the environment, the very life-stream of our existence. This concern, coupled with excellent communication skills, gives the graduate the edge needed to meet the environmental challenges of the 90s and into the 21st century.

According to the U.S. Department of Labor, Bureau of Labor Statistics, environmental engineering technologists are employed in almost every industry. Employment is expected to grow by 32%, continuing to grow faster than average and significantly increasing its share of total employment by 2005.

Degree Requirements

General Education Program - 36 Hours

Tracks A, B, and C (48 Hours)

The General Education Program is composed of 48 credit hours of which 12 hours may be satisfied by requirements in the environmental engineering technology curriculum. Further information about the GEP is listed on page 55 of the current catalog or can be obtained from the department chairperson's office.

Mathematics Component 16 Hours

Natural Sciences Courses 45 Hours

Engineering Technology Courses 19 Hours

Synthesis 4 Hours

Environ. Eng. Tech. Courses 34 or 62 Hours

Track Requirement 12, 15, or 43 Hours

Total Hours Required:

Track A 197 Hours

Track B 194 Hours

Track C 197 Hours

Mathematics Component (16 Hours)

TRACKS A, B, & C

Course No.	Course	Cr. Hrs.
MATH 131	Pre-Calculus 1	4
MATH 132	Pre-Calculus 2	4
MATH 201	Calculus 1	4
MATH 202	Calculus 2	4

Natural Sciences Courses (45 Hours)

TRACKS A, B, & C

BIOL 151	Principles of Biology	5
BIOL 350	Microbiology	5
CHEM 141	General Chemistry 1	5
CHEM 142	General Chemistry 2	5
CHEM 143	General Chemistry 3	5
CHEM 200	Introduction to Organic Chemistry	4
GEOG 311	Air Pollution	4
GEOL 112	Environmental Geology	4
PHYS 201	Physics 1 (Mechanics)	4
PHYS 203	Physics 3 (Energy)	4

Engineering Technology Courses (19 Hours)

TRACKS A, B, & C

ETCO 115	VBASIC Computer Programming (OR ETCO 116, or 117, or 150)	4
ETCO 210	Occup. Safety & Health Management	3

ETCO 225	Industrial Management	3
ETEG 105	Blueprint Reading	2
ETEG 110	Engineering Drawing 1	3
ETEM 110	Introduction to Electricity/Electronics	4

Synthesis (6 Hours)

TRACKS A, B, & C

ENGL 121	Technical Writing	4
----------	-------------------	---

Environmental Engineering Technology Courses (34 or 62 Hours)

TRACKS A & B (62 HOURS)

ETEV 110	Intro. to Environ. Eng. & Regulations	3
ETEV 120	Laboratory Techniques	4
ETEV 130	Water Treatment Techniques	3
ETEV 210	Wastewater Treatment Techniques	3
ETEV 220	Hazardous Waste	3
ETEV 230	Intro. to Solid Waste Technology	3
ETEV 240	Industrial Waste Treatment	3
ETEV 250	Fluid Mechanics	3
ETEV 260	Automation for Environmental Tech.	3
ETEV 270	Industrial Toxicology	4
ETEV 280	Hazardous Waste Operations	4
ETEV 290	Summer Cooperative Education 1	4
ETEV 310	Thermodynamics	3
ETEV 390	Summer Cooperative Education 2	4
ETEV 410	Eng. Hydrology for Technologists	3
ETEV 420	Intro. to Geographic Info. Systems	3
ETEV 422	ISO 14,000 Standards & Guidelines	3
ETEV 430	Stat. Proc. for Analysis of Env. Data	3
ETEV 440	Environmental Law & Policy	3

TRACK C (34 HOURS)

ETEV 110	Intro. to Environ. Eng. & Regulations	3
ETEV 120	Laboratory Techniques	4
ETEV 220	Hazardous Waste	3
ETEV 230	Intro. to Solid Waste Technology	3
ETEV 240	Industrial Waste Treatment	3
ETEV 270	Industrial Toxicology	4
ETEV 290	Summer Cooperative Education 1	4
ETEV 310	Thermodynamics	3
ETEV 390	Summer Cooperative Education 2	4
ETEV 430	Stat. Proc. for Analysis of Env. Data	3

Track Requirement (15, 12, or 43 Hours)

TRACK A: HAZARDOUS MANAGEMENT (15 HOURS)

ETEV 345	Management of Hazardous Material	3
ETEV 355	Hazrd. Waste Treat. & Control Tech.	3
ETEV 365	Environmental Risk Analysis	3
ETEV 435	Env. Monitoring & Sampling Systems	3
ETEV 445	Hazardous Site Remediation	3

OR

TRACK B: WASTE TREATMENT TECHNICIAN (12 HOURS)

ETEV 315	Water Treatment 2	3
ETEV 325	Wastewater Treatment 2	3
ETEV 335	Air Pollution 2	3
ETEV 425	Solid Waste Disposal 2	3

OR

**TRACK C: HEALTH PHYSICS TECHNOLOGIST
(43 HOURS)**

Course No.	Course	Cr. Hrs.
AHNR 285	Topics in Health Physics 1	14
AHNR 286	Topics in Health Physics 2	14
EDEV 345	Management of Hazardous Material	3
EDEV 355	Hazrd. Waste Treat. & Control Tech.	3
EDEV 425	Solid Waste Disposal 2	3
EDEV 435	Env. Monitoring & Sampling Systems	3
EDEV 445	Hazardous Site Remediation	3

Bachelor of Science in Plastics Engineering Technology

Products made by the plastics industry range from simple articles like bottles and cups to highly intricate molded parts for the automotive, electronics, and medical products industries. Their production requires knowledgeable technologists who can design a product, select the best plastic for that product, design a mold, and establish the optimum operating conditions for the machines that are used to mold the product. The plastics engineering technology program prepares you to become a member of the team that accomplishes these objectives.

The program emphasizes plastics processing operations and includes significant components in the areas of materials, mold design, and production methods. Graduates of the program are prepared to assume an entry-level management position in a plastics production environment. Typical job titles are process engineer, project engineer, and production manager.

Degree Requirements

General Education Program (48 Hours) 36 Hours

The General Education Program is composed of 48 credit hours of which 12 hours may be satisfied by the following mathematics and science requirements in the plastics engineering technology curriculum. Courses that apply are MATH 131 and Natural Science Option 2: CHEM 121, 122, and 200. Further information about the GEP is listed on page 55 of the current catalog or can be obtained from the department chairperson's office.

Engineering Technology Courses	10 Hours
Mathematics/Science Courses	42 Hours
Communications Courses	6 Hours
Plastics Engineering Tech. Courses	92 Hours
Total Hours Required	186 Hours

Engineering Technology Courses (10 Hours)

Course No.	Course	Cr. Hrs.
ETCO 117	Software Tools for Technology	4

ETCO 210	Occup. Safety & Health Management	3
ETCO 225	Industrial Management	3

Mathematics/Science Courses (42 Hours)

CHEM 141	General Chemistry 1	5
CHEM 142	General Chemistry 2	5
CHEM 200	Introduction to Organic Chemistry 1	4
MATH 131	Pre-Calculus 1	4
MATH 132	Pre-Calculus 2	4
MATH 201	Calculus 1	4
MATH 202	Calculus 2	4
PHYS 201	Physics 1 (Mechanics)	4
PHYS 202	Physics 2 (Electricity & Magnetism)	4
PHYS 203	Physics 3 (Energy)	4

Communications Courses (6 Hours)

BUOA 115	Powerpoint Fundamentals	2
ENGL 121	Technical Writing 1	4

Plastics Engineering Tech. Courses (92 Hours)

ETPL 100	Intro. to Plastics Manufacturing	4
ETPL 120	3D Drawing Using AutoCAD®	3
ETPL 200	Plastics Proc. (Injection Molding)	4
ETPL 205	Plastics Processing (Extrusion)	4
ETPL 210	Plas. Proc. (Thermoform. & Finish.)	4
ETPL 215	Plastics Processing (Thermosets)	4
ETPL 220	Plant & Facilities Engineering	4
ETPL 230	Properties of Polymeric Materials	4
ETPL 235	Statistical Proc./Quality Control 1	4
ETPL 248	Plastics Processing Lab 1	1
ETPL 310	Plant Layout & Material Handling	3
ETPL 320	Production Cost Analysis	4
ETPL 330	Material Science	4
ETPL 335	Statistical Proc./Quality Control 2	4
ETPL 340	Advanced Manufacturing	4
ETPL 345	Advanced Processing 1	4
ETPL 360	Plastics Part Design	4
ETPL 365	Plastic Part Analysis 1	4
ETPL 370	Plastic Part Analysis 2	4
ETPL 435	Statistical Proc./Quality Control 3	4
ETPL 445	Advanced Processing 2	4
ETPL 448	Plastics Processing Lab 2	1
ETPL 453	Advanced Processing 3	4
ETPL 460	Composites	4
ETPL 470	Senior Project	4

Associate Degrees

Associate of Applied Science in Computer Aided Design

The advent of computer aided design is one of the most significant developments in the drafting area. Not only has CADD revolutionized the way in which drawings are produced, but when coupled with computer aided machining (CAM), the entire manufacturing process is bound together and integrated.

Shawnee State's CADD department uses industry standard hardware and software in all classes. Unless otherwise stated, all classes utilize the latest release of AutoCAD,® which holds over 74% of the PC/CADD market.

Positions for CADD operators exist in:

Aerospace	Medical equip. mfg.
Architecture	Packaging
Automotive industries	Petroleum
Building/construction	Piping
Civil engineering	Plastics
Defense	Tool design
Electronics	Transportation
Foundry	Utilities
Machining	Welding

Students graduating from the program expect occupations as, for example, CADD operators, draftspersons, engineering designers, detailers, and technical illustrators.

CADD Sequence

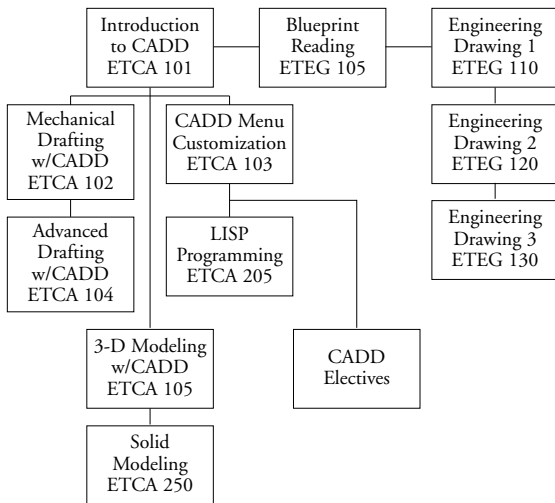

Suggested Technical Electives

Course No.	Course	Class Hrs.	Lab Hrs.	Credit Hrs.
BUIS 201	C Language	2	3	3
ETCO 202	Statics & Strength of Mat.	3	3	4
ETEM 111	Electrical Fund. 1 (DC)	2	3	3
ETIN 120	Process Instrumentation	3	3	4
ETPL 100	Plastics Manufacturing	2	3	3

CADD Electives *May be used as technical electives.*

ETCA 120	Introduction to CADKEY®	2	3	3
ETCA 150	Computer Aided Machining	2	3	3
ETCA 202	Piping Drawing w/ CADD	2	3	3
ETCA 203	Welded Parts Des. w/CADD	2	3	3

ETCA 204	Cst. & Mld. Des. w/CADD	2	3	3
ETCA 230	Rendering & Animation	2	3	3
ETCA 285	Special Topics in CADD	?	?	?
ETEG 285	Special Topics in Eng. Drw.	?	?	?

Sample Schedule

Course No.	Course	Class Hrs.	Lab Hrs.	Credit Hrs.
FIRST QUARTER (Fall)				
ENGL111S	Discourse & Composition	4	0	4
ETCA 101	Introduction to CADD	2	3	3
ETCO 110	Comp. Appl. for Eng. Tech.	2	0	2
ETCO 115	VBASIC Computer Prog.	4	0	4
ETEG 110	Engineering Drawing 1	2	3	3
ETEG 105	Blueprint Reading	2	0	2
Totals		16	6	18
SECOND QUARTER (Winter)				
ENGL 112S	Composition & Research	4	0	4
ETCA 102	Mechanical Drafting w/CADD	2	3	3
ETCA 103	CADD Menu Customization	2	3	3
ETEG 120	Engineering Drawing 2	2	3	3
MATH 130	Intermediate Algebra	4	0	4
Totals		14	9	17
THIRD QUARTER (Spring)				
ENGL 121	Technical Writing	4	0	4
ETCA 104	Advanced Drafting w/CADD	2	3	3
ETCA 105	3-D Modeling w/CADD	2	3	3
ETEG 130	Engineering Drawing 3	2	3	3
MATH 131	College Algebra	4	0	4
Totals		14	9	17
FOURTH QUARTER (Fall)				
ETCA 205	LISP Programming	2	3	3
ETCA	CADD Elective	2	3	3
ETCO 210	Occ. Safety & Health Mgr.	3	0	3
ETMA 140	Machine Tools	2	3	3
SOCI - - -	Elective (advisor approved)	4	0	4
Totals		13	9	16
FIFTH QUARTER (Winter)				
ETCA 220	Microstation®	2	3	3
ETCO 220	Hydraulics & Pneumatics	2	3	3
MATH 132	Trigonometry & Analytic Geom.	4	0	4
PHYS 201	Physics 1 (Mechanics)	3	3	4
ETXX - - -	Technical Elective	2	3	3
Totals		13	12	17
SIXTH QUARTER (Spring)				
ETCA 201	Small Bldg. Design w/CADD	2	3	3
ETCA 250	Solid Modeling	2	3	3
ETCA	CADD Elective	2	3	3
PHYS	PHYS Elective (<i>choose either 202 or 203 or NTSC 110S</i>)	3	3	4
SPCH 103	Public Spk. & Human Com.	3	0	3
Totals		12	12	16

Associate of Applied Science in Electromechanical Engineering Technology

Modern life is very dependent on electromechanical technology; nearly every aspect of living is dependent on electricity. This program prepares you to become a competent electromechanical

technician capable of working and communicating with engineers, scientists, and production personnel.

The job market is almost unlimited for graduates of our program. Examples of positions in which our graduates are employed include:

- Computer development technician
- Automation service technician
- Design technician
- Draftsman
- Electrician
- Electronic assembler
- Electronic assembly foreman
- Instrumentation technician
- Maintenance foreman
- Robotics technician

Individuals who have completed this degree at Shawnee State may continue their education in the electromechanical technology completion program at Miami University and earn a bachelor of science in applied science. For additional information, contact Ken Warfield at Shawnee State, 740.351.3465, or e-mail kwarfield@shawnee.edu.

Sample Schedule

Course No.	Course	Class Hrs.	Lab Hrs.	Credit Hrs.
FIRST QUARTER				
ENGL 111S	Discourse & Composition	4	0	4
ETEG 110	Engineering Drawing 1	2	3	3
ETEM 111	Electrical Fund. 1 (DC)	3	3	4
MATH 130	Intermediate Algebra	4	0	4
	Totals	13	6	15
SECOND QUARTER				
ENGL 112S	Composition & Research	4	0	4
ETCA 101	Introduction to CADD	2	3	3
ETEM 112	Electrical Fund. 2 (AC)	3	3	4
ETEM 115	Electromechanical Devices	3	3	4
MATH 131	College Algebra	4	0	4
	Totals	16	9	19
THIRD QUARTER				
ENGL 121	Technical Writing	4	0	4
ETEM 121	Electronics 1	3	3	4
ETEM 130	Electromechanical Drawing	1	3	2
ETCO 115	VBASIC Computer Prog. (or ETCO 116, or 117, or 150)	4	0	4
MATH 132	Trig. & Analytic Geometry	4	0	4
	Totals	16	6	18
FOURTH QUARTER				
ETCO 210	Occ. Safety & Health Mgt.	3	0	3
ETEM 122	Electronics 2	3	3	4
ETEM 201	Electromechanical Systems	2	3	3
MATH 201	Calculus 1	4	0	4
PHYS 201	Physics 1 (Mechanics)	3	3	4
	Totals	15	9	18
FIFTH QUARTER				
ETCO 220	Hydraulics & Pneumatics	2	3	3
ETEM 208	Automation Fundamentals	3	3	4
ETEM 209	Robotics	2	3	3

ETEM 211	Electronic Logic Circuits 1	3	3	4
SOCI XXX	GEP Social Sciences	4	0	4
	Totals	14	12	18

SIXTH QUARTER

ETCO 202	Statics/Strength Materials	3	3	4
ETEM 212	Electronic Logic Circuits 2	3	3	4
ETEM 215	Electromechanical Design	1	6	3
ETEM 220	Technical Presentations	1	3	2
PHYS 203	Physics 3 (Energy)	3	3	4
	Totals	11	18	17

Associate of Applied Science in Plastics Engineering Technology

Plastics is one of the fastest growing industries in the United States, with an economic impact exceeding \$100 billion annually and providing approximately 1.5 million jobs. As it continues its rapid growth in both sales and consumption, the plastics industry will continue to lead others in both expansion and stability.

Our associate degree program prepares you to become a valuable and integral part of the plastics field. Graduates enter positions dealing with injection molding, extrusion, blow molding, thermoforming, structural and nonstructural foams, rotomolding, supervision, industrial statistics, mold preparation, setup, quality control, production control, fabrication, and semiprofessional research and development. Positions available to the plastics technology graduate include:

- Process engineer
- Production technician
- Senior technician
- Application research technician
- Technician service representative
- Quality control technician
- Chemical sales or technical service representative

Graduates of this associate degree program have the option of applying their two years directly into the bachelor's program in a 2+2 fashion. This gives you the flexibility to leave at the end of two years or finish the bachelor's degree in four years.

Sample Schedule

Course No.	Course	Class Hrs.	Lab Hrs.	Credit Hrs.
FIRST QUARTER				
CHEM 141	General Chemistry 1	4	3	5
ENGL 111S	Discourse & Composition	4	0	4
ETPL 100	Plastics Manufacturing	4	0	4
MATH 130	Intermediate Algebra (If needed for math placement)	4	0	4
	Totals	12-16	3	13-17

SECOND QUARTER				
ENGL 112S	Composition & Research	4	0	4
MATH 131	Pre-Calculus 1	4	0	4
PHYS 201	Physics 1 (Mechanics)	3	3	4
	Totals	11	3	12
THIRD QUARTER				
CHEM 200	Intro. to Organic Chemistry	3	3	4
ENGL 115S	Composition & Literature	4	0	4
ETPL 205	Extrusion/Blow Molding	4	0	4
MATH 132	Pre-Calculus 2	4	0	4
	Totals	15	3	16
FOURTH QUARTER				
ETCO 210	Occ. Safety & Health Mgt.	3	0	3
ETPL 200	Injection Molding	4	0	4
ETPL 220	Plant & Facilities Eng.	4	0	4
ETPL 235	Stat. Process/Quality Con.	4	0	4
MATH 201	Calculus 1	4	0	4
	Totals	19	0	19
FIFTH QUARTER				
ENGL 121	Technical Writing 1	4	0	4
ETCO 117	Software Tools for Tech.	4	0	4
ETPL 215	Thermosets	4	0	4
PHYS 203	Physics 3 (Energy)	3	3	4
	Totals	15	3	16
SIXTH QUARTER				
ETPL 120	3D Drawing/AutoCAD®	2	3	3
ETPL 210	Thermoforming & Finishing	4	0	4
ETPL 230	Prop. of Polymeric Materials	4	0	4
ETPL 248	Plastics Processing Lab	0	3	1
PHYS 202	Physics 2 (Electricity)	3	3	4
	Totals	13	9	16

Certificates

Computer Aided Drafting and Design Technician Program

The one-year CADD certificate program allows you to quickly develop skills in drafting and CADD operation. It prepares you for an occupation as a drafter or CADD operator using the latest version of AutoCAD. In this three-quarter program, you take three drafting courses and at least five courses in CADD. The remaining three electives allow you to explore other areas of technology and to specialize in an individual field of study. If you wish to further your studies after completing the certificate, you may choose to continue in the associate degree program in CADD.

Sample Schedule

Course No.	Course	Class Hrs.	Lab Hrs.	Credit Hrs.
FIRST QUARTER				
ETCA 101	Introduction to CADD	2	3	3
ETCO 110	Comp. Appl. for Eng. Tech.	2	0	2
ETXX - - -	Elect.: CADD fclty. approv.	2	3	3

ETEG 110	Engineering Drawing 1	2	3	3
ETEG 105	Blueprint Reading	2	0	2
MATH 105	Plane Geometry	4	0	4
	Totals	14	9	17

SECOND QUARTER

ETCA 102	Mech. Drafting w/CADD	2	3	3
ETCA 130	CADD Menu Customization	2	3	3
ETEG 120	Engineering Drawing 2	2	3	3
MATH 130	Intermediate Algebra	4	0	4
ETXX - - -	Elect.: CADD fclty. approv.	2	3	3
	Totals	12	12	16

THIRD QUARTER

ETCA 104	Adv. Drafting w/CADD	2	3	3
ETCA 105	3-D Modeling with CADD	2	3	3
ETCA - - -	CADD Elective	2	3	3
ETEG 130	Engineering Drawing 3	2	3	3
ETXX - - -	Elect.: CADD fclty. approv.	2	3	3
	Totals	10	15	15

Plastics Engineering Technology

The one-year plastics engineering technology certificate program combines various coursework in plastic processes, production, processing, and the basic plastic science necessary for a realistic grasp of the industry.

Graduates of the program are prepared for entry into one of the largest production environments in the country. Entry-level positions include machine operator, material handler, and mold set-up assistant.

Students interested in earning this certificate are strongly advised to schedule an advising appointment with a plastics engineering technology faculty to develop an approved academic plan.

The curriculum is undergoing course revisions. Contact the Department of Industrial and Engineering Technologies for the latest program course requirements.

Web Engineering Technology

This certificate program focuses on using the latest object oriented software engineering principles to develop web applications for the next generation of open web services that are now becoming available. Technologies like XML, application servers, software components, web databases, open services gateways, and wireless device applications are covered in depth along with techniques for integrating these technologies in order to develop web services. The certificate is a five-course/three-quarter program and is especially designed to enhance the abilities of individuals who have earned an A+, Cisco, Microsoft MSCE, jCert Java, or a similar certification and for individuals who would like to develop the skills necessary to meet the challenges of the web services model that the

internet is currently moving towards. For more information on this certificate, visit <http://cyber.shawnee.edu/etwb>.

Sample Schedule

Course No.	Course	Class Hrs.	Lab Hrs.	Credit Hrs.
FIRST QUARTER				
ETEC 201	Object Oriented Prog. 1	4	0	4
ETWB 111	XML 1 (XHTML)	4	0	4
	Totals	8	0	8
SECOND QUARTER				
ETEC 202	Object Oriented Prog. 2	4	0	4
ETWB 112	XML 2 (DOM, SAX)	4	0	4
	Totals	8	0	8
THIRD QUARTER				
ETEC 203	Object Oriented Prog. 3	4	0	4
	Totals	4	0	4

Minors

Plastics Engineering Technology

A minor in plastics engineering technology offers students in any of Shawnee State's other baccalaureate programs an opportunity to broaden their major course of study with an auxiliary focus in plastics engineering technology. The minor requires eight classes (24-25 credit hours) from the plastics engineering technology program and is designed for students in degree programs other than plastics engineering technology.

Students interested in earning this certificate are strongly advised to schedule an advising appointment with a plastics engineering technology faculty to develop an approved academic plan.

The curriculum is undergoing course revisions. Contact the Department of Industrial and Engineering Technologies for the latest program course requirements.

Computer Aided Design (26-28 Hours)

Students enrolled in any of Shawnee State's baccalaureate programs may elect to pursue a minor in computer aided design. A CAD minor provides the computer, technical, and design skills necessary to stay competitive in today's job market. Students use the latest version of AutoCAD®. The popularity of this software ensures a growing demand for proficient AutoCAD operators.

Required Courses (17 Credits)

Course No.	Course	Cr. Hrs.
ETCA 101	Introduction to CADD	3
ETCA 102	Mechanical Drafting with CADD	3
ETCA 103	CADD Menu Customization	3
ETCA 105	3D Modeling with CADD	3
ETEG 105	Blueprint Reading	2
ETEG 110	Engineering Drawing 1	3

Elective Courses (9-11 Credits)

The number of credits is dependent on sequence selected. Choose from one of the following.

SEQUENCE A

BUAI 101	Computer Applications 1	4
BUAI 103	Computer Applications 2	4

SEQUENCE B

BUIS 101	Intro. to Computer Info. Systems	4
BUIS 103	Visual BASIC 1	4

SEQUENCE C

ETCO 110	Computer Applications for Eng. Tech.	2
ETCO 115	V BASIC Computer Programming	4

AND, select one of the following courses (regardless of which sequence is chosen):

ETCA 104	Advanced Drafting with CADD	3
ETCA 150	Computer Aided Machining	3
ETCA 201	Small Building Design	3
ETCA 230	Rendering and Animation	3

Robotics Option

(Offered upon sufficient demand)

Students enrolled in the associate degree programs in computer aided drafting and design and electro-mechanical and plastics engineering technology may also pursue a concentration in robotics. You must have electromechanical faculty approval and complete 15 credit hours of the following courses in numerical sequence.

ETCO 230	Introduction to Robotics OR
ETEM 209	Robotics
ETRO 211	Robotic Interfacing
ETRO 212	Robotic Applications
ETRO 213	Robotic Maintenance/Serviceing

Pre-Engineering Curriculum

The College of Professional Studies and the College of Arts and Sciences offer a two-year pre-engineering program to students who intend

to pursue a career in engineering. Designed for students who wish to transfer to a traditional engineering school, this two-year curriculum includes technical, humanities, and liberal arts courses. Pre-engineering students are enrolled in the Department of Engineering Technologies or College of Arts and Sciences and are advised by appropriate faculty. These faculty are also available to help you decide which particular branch of engineering you might wish to pursue.

While this curriculum is designed to meet the general needs of many traditional engineering institutions, you should verify any specific needs of the school and discipline of your choice. In addition, most of this coursework will satisfy scholastic requirements if you wish to pursue a degree in engineering technology or natural sciences, concentrating in physics, through Shawnee State University. Another option is an associate of science degree in individualized studies with concentrations in a number of technical disciplines.

The curriculum is undergoing course revisions. Contact the Department of Industrial and Engineering Technologies for the latest program course requirements.

Pre-Engineering General Course Sequence

Course No.	Course	Cr. Hrs.
FIRST YEAR		
FALL QUARTER		
CHEM 141	General Chemistry 1	5
ENGL 111S	Discourse & Composition	4
ETCO 110	Computer Applications for Eng. Tech.	2
ETCO 115	VBASIC Computer Programming	4
MATH 201	Calculus 1	4
	Total	19
WINTER QUARTER		
CHEM 142	General Chemistry 2	5
ENGL 112S	Composition & Research	4
ETEC 102	Structured Programming w/C	4
MATH 202	Calculus 2	4
PSYC 101	Introduction to Psychology	4
	Total	21
SPRING QUARTER		
CHEM 143	General Chemistry 3	5
ECON 202	Principles of Macroeconomics	4
ENGL 115S	Composition & Literature	4
ETEC 103	Data Structures with C	4
MATH 203	Calculus 3	4
	Total	21

SECOND YEAR

FALL QUARTER

ENGL 121	Technical Writing	4
ETCA 101	Introduction to CADD	3
ETEG 110	Engineering Drawing	3
MATH 204	Calculus 4	4
PHYS 211	Calculus-Based Physics 1	4
	Total	18

WINTER QUARTER

IDST 225S	Civilization & Literature 1	4
MATH 301	Ordinary Differential Equations	4
PHIL 320S	Ethics in Public & Private Life	4
PHYS 212	Calculus-Based Physics 2	4
	Total	16

SPRING QUARTER

IDST 226S	Civilization & Literature 2	4
PHYS 213	Calculus-Based Physics 3	4
SOSC 110S	Foundations of Social Science	4
SOCI 150	Principles of Statistics	4
SPCH 103	Public Speaking & Human Comm.	3
	Total	19

Special Notes

- Students starting in an even numbered year should schedule physics in the first year and chemistry in the second. Students starting in an odd numbered year, should follow the schedule shown above.
- Some prerequisites are presumed, and remediation will be required if not met:
 - a) CHEM 141 requires high school chemistry or CHEM 121 and corequisite of MATH 130.
 - b) MATH 201 requires placement or the following sequence: MATH 099, 101, 105, 130, 131, 132. (This sequence may be entered at any point.)



PRE-COLLEGE PROGRAMS

Pre-College Programs

The following programs—with the exception of BASICS and BEAR CUBS—are part of the federal TRIO program, are funded by the U.S. Department of Education, and are housed on the Shawnee State campus. If you would like more information about any of the programs, please call Barb Bradbury, 740.351.3439, or the numbers below.

BASICS

Shawnee BASICS, Basic Adult Skills in a College Setting, is designed to allow students to get a GED, learn to read, prepare for college, or enhance job skills. BASICS is free and is designed as a self-paced course of study.

Housed in the Advanced Technology Center, BASICS focuses on reading, writing, and arithmetic; however, it includes instruction in other areas as well. Classes in problem-solving, listening, self-esteem, team work, time and personal management, and basic keyboarding skills enhance the marketability of the unemployed in Scioto County and the surrounding area.

Please call 740.351.3325 for further information about BASICS.

The BEAR CUBS Program

Shawnee State's BEAR CUBS program is funded by a grant from the Ohio Appalachian Center for Higher Education and is also supported by the Shawnee State University Development Foundation. The program's name is an acronym for Building Enthusiasm for Access and Retention in College by Understanding the Basics for Success. The program serves all districts in Scioto County and selected schools in the Pike County area. BEAR CUBS provides classroom presentations and campus visits, which allow area students to participate in a variety of college campus activities. The emphasis of BEAR CUBS is on helping students explore career options available to them as well as the value of adequate planning regarding careers that require a college education.

For more information about the BEAR CUBS program, contact the coordinator at 740.351.3543 or e-mail lrased@shawnee.edu.

Talent Search

Shawnee State University's Educational Talent Search program is funded through a grant from the U.S. Department of Education and serves residents of Lawrence, Pike, and Scioto counties. The program provides services to students in grades 6-12 who want to pursue a college education. Participants must meet certain guidelines, as established by the U.S. Department of Education.

Participants receive:

- Educational Counseling: ACT test preparation workshops; information about specific colleges, universities, and other schools; assistance selecting, applying to, and enrolling in educational programs after high school; college life workshops; contacts with school representatives; and assistance selecting high school classes in preparation for college.
- Career Counseling Services: Career exploration and planning, career interest testing and follow-up, goal setting.
- Financial Aid Information and Assistance: Financial aid workshops for parents and students, information about grants, scholarships, college work programs, and student loans.
- Assistance with Special Needs: Identification of support services for disabled students who may need additional help for college or vocational success (i.e., tutoring and counseling).

The Talent Search program is located on the ground floor of the Administration Building and is open Monday through Friday, 8:00 a.m. to 5:00 p.m. Please call 740.351.3558 for further information.

Upward Bound

Shawnee State University's Upward Bound program is funded through a grant from the U.S. Department of Education and serves students from several Scioto County high schools. The program focuses on students who are interested in attending college but who may need an extra "push" to turn that interest into reality. Upward Bound provides academic, social, recreational, cultural, and counseling services in order to generate the skills, motivation, and self-confidence necessary for success in college.

The primary goal of the program is to prepare students for college or technical education after high school. This is completed in two phases.

The first phase is the academic year component. During this time, Upward Bound develops college study skills and provides tutoring and counseling. Also, the program meets once a month for planned educational and exciting social activities that reward the students for their efforts.

The second phase is the summer component. During the summer, the students take part in a six-week, residential program on the campus of Shawnee State University. While living in campus housing, the students take interesting academic courses and enjoy fun social activities and educational travel experiences. The students have the opportunity to work, too. In other words, the student gets a taste of what college life is all about.

High school students are selected for the Shawnee State Upward Bound program if:

- They show potential for academic success in college, but lack adequate skills, motivation, or self-confidence.
- They are first generation college students, meaning that neither of their parents earned a bachelor's (four-year) degree. Other students will be considered for the program, but the majority must be first-generation college students.
- Their family income does not exceed the guidelines determined by the U.S. Department of Education. Other students will be considered for the program, but the majority must come from families whose income does not exceed the established guidelines.

For more information about the Upward Bound program, please contact our office, which is located in the Trio Center in the Administration Building. Our phone number is 740.351.3439.

Upward Bound Math Science Center

The Upward Bound Math Science Center (UBMSC) is designed to provide students in Appalachian Ohio, Kentucky, and West Virginia with an exciting learning experience in the math and science fields. The UBMSC at Shawnee State University provides academic, social, recreational, cultural, and counseling services in order to generate the skills, motivation, and self-confidence necessary for students to succeed in a university math or science program. The program is designed to expand the students' math and science abilities

and help prepare them for a math or science program at the university level.

During the summer, students are part of a six-week, residential program at Shawnee State University. While living on campus, students complete inquiry-based projects to make the connection between math and science and real world applications. They also take enrichment classes, are involved in social and recreational activities, and have the opportunity to travel to interesting places. Students get to know what college life is like through these different experiences.

During the academic year, professors and UBMSC staff mentor students via phone, newsletter, and Internet. Students are invited to submit project reports, creative writing pieces, and personal news, which may be included in a monthly newsletter or posted on the UBMSC web page. There are also opportunities for some students to participate in weekend activities throughout the year.

We recruit students from Appalachian Ohio, Kentucky, and West Virginia, who are not served currently by a UBMSC. Eligible students must meet the following criteria:

- Currently enrolled in grades 10 (sophomores) or 11 (juniors)
- Meet Federal Income Guidelines and/or be potential first generation college students (neither parent has earned a 4-year degree)
- Interest in a math or science career
- Minimum 2.3 GPA

Note: Students with parents who have a two-year degree may apply to the program.

For more information, contact the UBMSC office at 740.351.3439 or toll free 1.877.SSU.UBMS (778.8267).



UNIVERSITY
OUTREACH
SERVICES

University Outreach Services

Recognizing the ever-changing face of education, educators, and students, University Outreach Services serves as the gateway to the community, reaching out to learners in an ever-expanding service area. It provides the stable foundation upon which experimental educational ideas are offered, partnerships are formed, and quality programming and services are delivered.

Developed through a reorganization and redirection of university academic and community outreach services, the office is designed to provide a wide array of specialized educational opportunities. These include the educational and cultural enrichment opportunities critical to young students in the surrounding communities, technical training customized to meet the needs of workers in nearby businesses striving to compete in the high-tech work place, and the showcasing of the educational talent and expertise of Shawnee State's faculty and staff through distance education, integration of academic services, and research and development of cutting-edge programming.

The purpose of University Outreach Services is to provide leadership in program innovation, research, and development; sustain partnerships with regional educational, business and industry, and community organizations; and offer diversified quality programming and services.

Bureau of Worker's Compensation Health and Safety Training ■ The Ohio Bureau of Workers' Compensation Division of Safety and Hygiene offers a series of training courses covering critical health and safety issues for eligible segments of the Ohio business community. Shawnee State University, through its University Outreach Services, is one of six satellite training locations and serves the Southern Ohio area.

Community Education Program ■ The Community Education Program encompasses a broad range of noncredit personal development courses, programs, and activities, which are offered to the general public. Each fall and spring, a schedule of events is developed and distributed to the community. Courses that are included in the schedule are often suggested and taught by members of the community. Topics include ACT prep,

seasonal arts and crafts, photography, health and fitness, personal finance, creative writing, and a wide variety of interests. If you would like to teach a course or be placed on the mailing list, please call 740.351.3535.

Computer Enrichment Training ■ Community members interested in honing their computer skills in a noncredit setting may enroll in a variety of proficiency classes. New classes begin quarterly, offering training on many popular software packages. Training sessions designed specifically for a group or organization are also scheduled as needed. Outreach Services provides a mobile computer lab of state-of-the-art equipment, enabling Shawnee State to offer on-site computer education and skills training to area businesses and organizations.

District Science Day ■ Shawnee District 14 Science Day is one of 16 district science competitions sponsored by the Ohio Academy of Science (OAS) and hosted by colleges and universities across the state of Ohio. It annually attracts more than 200 students, grades 5-12, from Adams, Lawrence, Pike, and Scioto counties. It is an avenue for students to develop independent or team scientific research projects which may lead to an opportunity to compete at State Science Day in Columbus, Ohio.

Elderhostel ■ Elderhostel provides enrichment experiences for learners over 55. Senior citizens from all parts of the country spend a week at Shawnee State, becoming acquainted with the local culture and taking part in specially designed classes.

Grants Management ■ University Outreach Services provides resources and technical assistance to university-wide grant-seeking efforts. As the campus liaison for the Grants Resource Center, Outreach Services provides access to federal funding sources.

Microsoft® IT Academy Program ■ Certification in information technology is offered through the Microsoft® IT Academy. Outreach Services has teamed with Microsoft to present cutting edge training and materials and hands-on experience. All instructors are trained and certified on the latest Microsoft technologies.

Ohio Academic Competitions ■ The Ohio Academic Competition (OAC) provides Ohio high school students the opportunity to exercise their reasoning, critical thinking, and

recall skills in a healthy, competitive environment. Top students from all parts of Ohio are introduced to Shawnee State through the OAC. As the statewide point of coordination, Outreach Services registers nearly 90 teams for participation in regional competitions at four sites in Ohio. Shawnee State hosts the southeast regional statewide competition.

Online Learning ■ University Outreach Services offers over 200 noncredit continuing education courses online. Online courses provide flexibility in scheduling and location. All you need is access to the Internet. Courses are designed for the student's personal enrichment and professional development. All courses are accessed through www.ed2go.com/shawnee.

Summer Honors Institute ■ The Ohio Department of Education funds the Summer Honors Institute for 16 selected state and private colleges and universities in Ohio. Approximately 150 students participate in the Summer Institute at Shawnee State University each year. The Institutes are designed to offer Ohio's talented and gifted high school sophomores and juniors intensive learning experiences and exposure to the hosting college's campus. Since Shawnee State became a part of the Summer Institute network, the University has consistently hosted one of the largest Institutes in Ohio each year.

College Tech Prep Ohio South Consortium

College Tech Prep is a partnership among business, industry, labor, and secondary and higher education. It is a primary strategy for systemic change in Ohio that prepares students for technology based careers demanded by the increasingly competitive global economic community.

Tech Prep is a National Education Reform Initiative, which was launched in 1991. The program is aimed at meeting the needs of business and industry for qualified, skilled workers in high demand, technical fields.

Tech Prep is a combined secondary and post-secondary program, which provides students with the following:

- A preparation for employment, careers, and education beyond high school.
- A hands-on, real world approach to teaching and learning that includes teamwork, worksite experiences, critical thinking, and problem solving.

- An integration of technical and academic curricula.
- A competency-based curriculum that enables students to certify their achievements.
- A planned sequence of courses from high school through an associate or baccalaureate degree.

Currently, programs in engineering, business, information technology, and health are available in the College Tech Prep program. The Ohio South Consortium partners Shawnee State University, Ohio University Southern Campus, and local school districts with a wide array of regional business and industry partners. College Tech Prep continues to grow and help students learn to prepare for the new career market.

Contract and Targeted Industries Training

The Contract Training programs as well as the Targeted Industries Training programs are initiatives of the Ohio Board of Regents and are coordinated through the Enterprise Ohio Network.

The programs share the common goal of creating partnerships with Ohio's businesses to build and maintain a world-class workforce by making improvements in quality, productivity, and competitive ability through employee training. Customized training is provided to area manufacturers with an emphasis on enhancing competitiveness, retention, and expansion.

Targeted Industries Training grant funds provide from 50 to 75 percent of the total cost of training, leaving only the remaining percentage to be paid by the company. This makes the much needed training affordable for Ohio's small businesses. Non-manufacturing businesses may also access funds for training employees in the area of information technology.

The Enterprise Ohio Network—of which Shawnee State is a member—is an association of two-year campuses in Ohio that partner with companies and public sector organizations as a part of the state's economic development infrastructure.

School-to-Work, Urban/Rural Opportunities Grant

Through an award from the U.S. Department of Labor, this initiative provides School-to-Work opportunities to students in the Northwest and

Washington-Nile School Districts, Scioto County Joint Vocational School, and Shawnee State. The purpose of School-to-Work is to encourage all students to explore their educational and occupational options. The School-to-Work opportunities the initiative at Shawnee State provides include . . .

Explore Your Future is a week-long summer career education program offered to area K-12 students on the Shawnee State campus. Explore Your Future helps students make connections between current interests and education and future career options. Students explore various careers through educational skill-building exercises, hands-on activities, field trips, and guest speakers.

Career Exploration for Women is offered annually to area middle school female students as an opportunity to explore nontraditional careers and occupations. This half-day program offers sessions representing over 35 nontraditional professions, and area women serve as instructors and role models in each workshop session.

Fellowships for Educators provides teachers in Northwest Local Schools, Washington-Nile Local Schools, Scioto County Joint Vocational School, and Shawnee State University with paid, work-based opportunities for intense, hands-on job training in area businesses of their choice.

Professional Development is offered to area educators to enhance their knowledge of the School-to-Work initiative through workshops, conferences, and training.

Twenty-first Century Community Learning Centers

Two three-year federal grants, totalling \$7.1 million per year, were awarded to Scioto County Joint Vocational School, Shawnee State University, and the Ohio South Tech Prep Consortium partner school districts to provide out-of-school activities for rural students at 36 community learning centers.

Each center, or “After School Mall,” offers a variety of opportunities, including tutoring and instruction for students at risk of failing the Ohio proficiency test or experiencing difficulties in the classroom. Expanded library hours and services, access to computer labs and Internet and computer training are featured at each center. Thematic and family reading programs, expanded drug and violence prevention education and counseling, and after school field trips to enrichment work sites and college campuses are provided. An emphasis is

placed on social development through organized recreational activities, food service, and supervised relaxation areas for students to rest and listen to music with friends. In an effort to remove transportation barriers for rural participants, the grant provides ample funds for transportation home from each center.

For more information about University Outreach Services contact:

Virginia Moore, Director
740.351.3281 • gmoore@shawnee.edu

Jerry Blanchard, Director, 21st Century
Community Learning Centers
740.351.3316 • jblanchard@shawnee.edu

George Lawson, Director, Ohio South Tech Prep
Consortium
740.351.3122 • glawson@shawnee.edu

Cathy Mullins, Academic Grants Officer/
Assistant to the Provost
740.351.3412 • cmullins@shawnee.edu

Megan Horne, Program Director, School-to-Work
740.351.3535 • mhorne@shawnee.edu

Mary Maroudis, Manager, Education for Industry
740.351.3370 • mmaroudis@shawnee.edu

Judy Meeker, Program Manager, Ohio South Tech
Prep Consortium
740.351.3411 • jmeeker@shawnee.edu

Dave Minnix, Pike County Coordinator, 21st
Century Community Learning Centers
740.289.2721, ext. 319 • dminnix_pj@scoca-
k12.org

Larry Musick, Manager, Contract Training
740.351.3304 • lmusick@shawnee.edu

Gary Salyer, Scioto County Coordinator, 21st
Century Community Learning Centers
740.259.5522, ext. 272 • gsalyer@scoca.k12.oh.us

David Seals, Lawrence County Coordinator, 21st
Century Community Learning Centers
740.867.6641 • ddseals@collins-cc.k12.oh.us



AFFILIATED ORGANIZATIONS



Ohio Appalachian Center for Higher Education

Located on the Shawnee State campus, the Ohio Appalachian Center for Higher Education (OACHE) is a consortium of the ten public colleges and universities within the 29-county Ohio Appalachian region. The mission of OACHE is to increase the level of educational attainment of residents by sponsoring access projects in member institutions and in public school districts.

OACHE operates with funds provided by the Ohio General Assembly through the Ohio Board of Regents. It combines the efforts of state government, higher education institutions, public school districts, and businesses to increase the college-going rate throughout this high poverty region.

In addition to Shawnee State University, consortium members include Belmont Technical College, Hocking Technical College, Jefferson Community College, Kent State University at Salem and East Liverpool, Muskingum Area Technical College, Ohio University, Rio Grande Community College, Southern State Community College, and Washington State Community College. The Board of Directors consists of a representative from the Ohio Board of Regents and the presidents of member institutions.

For more information, contact Wayne F. White, the executive director, at 740.351.3299.

Ohio Appalachian Educational Opportunity Center

The Ohio Appalachian Educational Opportunity Center (EOC) is a federal TRIO program, funded by the U. S. Department of Education. The EOC is housed on Shawnee State's campus, is sponsored by the Ohio Appalachian Center for Higher Education, and operates throughout the 29-county Ohio Appalachian region.

The EOC is a comprehensive counseling and referral program, providing FREE academic, vocational, career, and financial aid information to eligible adults.

EOC outreach coordinators are located on the campuses of Belmont Technical College, Hocking Technical College, Jefferson Community College, Kent State University - East Liverpool, Kent State University - Tuscarawas, Muskingum Area Technical College, Ohio University - Chillicothe, Rio Grande Community College, Southern State Community College, and Washington State Community College.

ROAD:MAP 2005

Realizing Our Academic Dreams: A Model Access Project, or ROAD:MAP 2005, is a program funded by the U. S. Department of Education's GEAR UP program (Gaining Early Awareness and Readiness for Undergraduate Programs).

ROAD:MAP 2005 is a regional initiative aimed at increasing the college-going rate of a chosen group of Ohio Appalachian students in the class of 2005. Over the next five years, the program will involve the students in activities which increase student academic performance, career awareness, self-esteem, aspirations to attend college, knowledge of postsecondary options and financial aid, and preparation for postsecondary education.

If you have questions about the program or would like further information, please call 740.351.3114 or 866.466.2243.



COURSE

DESCRIPTIONS



Please Note

The listing of a course in this catalog does not imply that the course is offered in a particular quarter, or even if the course is offered on a regular basis. Please check the Shawnee State University Course Schedule each quarter for up-to-date information on what courses are being offered.

In addition, it should be noted that some upper level courses are not included on these pages. Please contact your faculty advisor for further information.

Explanation of Prerequisites

Most learning beyond basic skills is dependent upon mastery of some prior skill or subject content. As a result, many courses at the University require the satisfaction of prerequisites prior to course enrollment. Prerequisites may be met by successful completion of the prior courses listed or by placement, via testing, into the course.

The academic division/college may withdraw a student from a course for which prerequisites have not been satisfied.

Explanation of Abbreviations

These abbreviations are found throughout the course descriptions on the following pages.

Preq. — Prerequisite

Coreq. — Corequisite

\$ — Indicates lab fee may apply to this course, using the formula in the box on the right.

GEP — Indicates General Education Program course (see pages 55-57 for details)

B — Business

Ed — Education

ET — Engineering Technology

FA — Fine Arts

HS — Health Sciences

H — Humanities

M — Mathematics

NS — Natural Sciences

SS — Social Science

Laboratory Fee Structure

A standard laboratory fee will be assessed to all courses with laboratory components within an academic department. They are as follows¹:

	Fee Per Credit Hour
Business	\$ 6.50
Education	5.50
Engineering Technology	9.00
Fine Arts	4.50
Health Sciences	10.25
Humanities	1.00
Mathematics	2.50
Natural Sciences	4.50
Social Sciences	0.00

¹ Some courses are approved for nonstandard fees.

Associate Degree Nursing

SPECIAL NOTE—ADNR (Associate Degree Nursing): *Only students officially accepted into the nursing program or those with approval of the program chair may take the courses with the ADNR prefix—with the exception of AHNR 135, which is open to all university students.*

ADNR 114 Introduction to Nursing (2) The history and evolution of nursing with an introduction to the health care system and exploration of the roles of nurses and other health care professionals. Legal and ethical aspects of practice are presented with an emphasis on individual values clarification and philosophy. An overview of the associate degree nursing program's organization framework is offered as orientation. *Preq. admission to ADN program; coreq. ADNR 181; \$ HS*

ADNR 181 Fundamentals of Nursing 1 (7) Introduction to the use of the nursing process to enable the individual to maintain or regain the ability to meet human needs across the life span. Emphasis is placed on the assessment components of the nursing process. Fundamental skills and related scientific principles of nursing are presented. Laboratory practice provides the opportunity to develop beginning skills in both technical and communication concepts of nursing. *Preq./coreq. admission to the nursing program, AHNR 135 and BIOL 130 or 310; 4.5 lec. 7.5 lab; \$ HS*

ADNR 182 Fundamentals of Nursing 2 (7) A beginning study of alteration in human needs through the process of holistic caring across the life span. Learning experiences take place in an acute care setting relating to the individual's internal and external environments. The student is introduced to the teaching/learning process and the role of the nurse as teacher. The student continues to develop fundamental skills with emphasis on surgical asepsis. *Preq. ADNR 181, AHNR 135, and BIOL 130 or 310; coreq. BIOL 131 or 320; preq./coreq. ADNR 114; 4 lec. 9 lab; \$ HS*

ADNR 193 Nursing Care of Adults and Children 1 (6) Focuses on alterations in the concepts of human needs for individuals across the life span in a variety of health care and community settings. Clinical practice opportunities include holistic caring, critical thinking/decision-making with application of technological innovations. *Preq. ADNR 182 and BIOL 131 or 320; coreq. CHEM 121; 3 lec. 9 lab; \$ HS*

ADNR 197 Transition to Registered Nursing (4) Focuses on key concepts needed for successful transition from the role of practical nursing to professional registered nursing. Presents the nursing process with emphasis on client assessment, nursing diagnosis, care planning, critical thinking, and teaching/learning. Demonstrates identified nursing skills in a variety of clinical settings. *Preq. active LPN/LVN license; 3 lec. 3 lab*

ADNR 203 Nursing Care of Adults and Children 2 (7) Applies the nursing process to culturally diverse individuals and their families across the life span. Human needs and responses to progressively complex conditions are explored. Critical thinking and clinical decision making are emphasized within a variety of health care delivery systems. *Preq. ADNR 193 and CHEM 121; 4 lec. 9 lab; \$ HS*

ADNR 204 Nursing Care of Adults and Children 3 (7) Applies the nursing process to culturally diverse individuals and their families across the life span experiencing human needs alterations. Human responses to life threatening critical conditions are explored to integrate previously identified alterations, as well as alterations in self-perception, self-concept, role relationship, and health perception-health management patterns. Critical thinking and clinical decision making are emphasized within a variety of health care delivery systems. *Preq. ADNR 203; 4 lec. 9 lab; \$ HS*

ADNR 224 Current Issues in Nursing (2) Focuses on health care and practice issues significant for associate degree nurse graduates practicing nursing in today's world. Ethical, legal, and political concerns as well as continuing education requirements are explored in this internet assisted course. *Preq. completion of first year nursing courses; \$ HS*

ADNR 251 Nursing Care of the Childbearing Family (5) Applies the nursing process to the study of the childbearing cycle and the newborn. The concepts of human needs, communication, and the role of the nurse providing care to culturally diverse families in acute care and home health care settings are discussed. Nursing interventions and technology needed to provide family-centered nursing in low and high risk situations are introduced. *Preq. completion of first year nursing courses; 3 lec. 6 lab; \$ HS*

ADNR 114 - ADNR 251

ADNR 252 - AHNR 286

ADNR 252 Mental Health and Behavioral Aberrations (5) Applies the nursing process to culturally diverse clients/families at risk for mental health and behavioral aberrations. Communication and group processes are utilized for teaching/learning experiences in a multidisciplinary milieu. Critical thinking, holistic caring, and clinical decision making are employed in addressing alterations of functional health patterns with emphases on health perception-health management, cognitive-perception, self perception-self concept, coping-stress tolerance, role-relationship, and value-belief. Clinicals include experiences within the community setting. *Preq. completion of first year nursing courses; PSYC 151; 3 lec. 6 lab; \$ HS*

ADNR 283 The Nurse as Coordinator of Care (8) Introduces the student to the role of the ADN nurse as coordinator of care. It is a culmination of concepts and processes taught in the ADN curriculum. Specifically, it is the application of the concepts of both provider and coordinator of care along with application of legal and ethical decision making issues for groups of clients in the delivery of nursing care. *Preq./coreq. completion of all other non-nursing and nursing courses; 4 lec. 12 lab; \$ HS*

ADNR 299 Nursing Special Topics (1-3) Individual or small-group study, under the supervision of an instructor, of topics not otherwise available to students. *\$ HS*

Allied Health

AHNR 100 Pre-Anatomy (4) Students are prepared for anatomy by learning medical roots, muscles, bones, body planes, and medical abbreviations. This is a special course developed primarily for all health science programs. *\$ HS*

AHNR 101 Introduction to Health Technologies (2) Introduction to the health professions, including history, responsibilities, and ethics. Includes introduction to the health science programs at Shawnee State University. *\$ HS*

AHNR 102 Medical Terminology (2) Introduction to medical terminology commonly used in health occupations. Emphasis is placed on prefixes, suffixes, and building and analyzing medical terms. *\$ HS*

AHNR 103 Chemical Principles for the Health Sciences (3) Basic inorganic, organic, and biochemistry principles as applied to human physiology. Includes metric and SI systems of measurement. Specifically designed for students in allied health or nursing programs. *Preq. acceptance into one of the health science programs or permission of health science department chair; \$ HS*

AHNR 104 Physical Principles for the Health Sciences (3) An applied health sciences course, designed specifically for PT assistant and athletic training students, dealing with a broad spectrum of physical systems, including energy, mechanics, and fluids along with conversions to the metric system. Utilizes problems in algebra-based functions. *Preq. acceptance into one of the PTA or ATC programs, placement or credit in MATH 101 or equivalent; \$ HS*

AHNR 135 Wellness and Health Promotion (3) Focuses on self-care strategies that encourage good health in individuals across the life span. The content encompasses a holistic approach that allows the individual to adopt and maintain positive lifestyle behaviors. Societal, environmental, cultural, and communication issues are also explored. *\$ HS*

AHNR 197 Rehabilitation Ethics (1-14) Individual or small group study, under the supervision of an instructor, of topics otherwise not available to students. *\$ HS*

AHNR 285 Topics in Health Physics 1 (1-14) Ten course modules of classroom instruction focus on biological effects of radiation, radiation protection standards, regulations/ALARA, respiratory protection, radiological control and monitoring, radiation protection and measurement, atomic and nuclear properties, interaction of radiation with matter, and dosimetry. *\$ HS*

AHNR 286 Topics in Health Physics 2 (1-14) A continuation of AHNR 285. Ten course modules of classroom instruction focus on biological effects of radiation, radiation protection standards, regulations/ALARA, respiratory protection, radiological control and monitoring, radiation protection and measurement, atomic and nuclear properties, interaction of radiation with matter, and dosimetry. *\$ HS*

AHNR 297 Rehabilitation Topics (1-14) Individual or small group study, under the supervision of an instructor, of topics not otherwise available to students. \$ HS

AHNR 325 Instructing Adults (3) Study of adult learning needs and participation patterns. Teaching styles and techniques best suited to adults are analyzed and demonstrated. \$ HS

AHNR 327 Methods of Teaching in Health and Occupations (3) The subject matter and teaching methodologies of health instruction in classrooms, laboratories, and community settings are analyzed and demonstrated. \$ HS

AHNR 354 Teaching/Learning in the Health Sciences (4) Integral aspects of the teaching and learning process related to the health science professional's role as an educator. Learning theories, teaching methods, and domains of learning are emphasized. The importance of assessment, planning, intervention, and evaluation as they relate to the clients' learning needs are examined. Students also identify various approaches to meet the diverse needs and learning styles of the client. *Preq. baccalaureate health science major or related area or consent of the instructor; \$ HS*

AHNR 402 Community Health Education (3) Philosophy of community health education with emphasis on historical, conceptual, and legal precepts. \$ HS

AHNR 461 Research Problems in Health and Recreational Education (4) Exploration of research methodologies, issues, and problems peculiar to health professions. \$ HS

Anthropology

ANTH 101 Introduction to Anthropology (4) An introduction to the biological nature of humans. The roots of primate and hominid evolution, speciation, cultural beginnings, and the processes of evolution in modern humans are examined.

ANTH 199 Topics in Anthropology (1-4) Individual or small-group study, under the supervision of instructor, of topics not otherwise available to students.

ANTH 250 Principles of Cultural Anthropology (4) How humans have adapted as foragers, hunters, farmers, and industrialists. The diversities of preliterate and living human societies, social structure, kinship, religion, and ecology are examined in cross-cultural settings. GEP

ANTH 299 Special Topics in Anthropology (1-4) Individual or small-group study, under the supervision of instructor, of topics not otherwise available to students. Separate courses repeatable for credit.

ANTH 340 MesoAmerica Before Columbus (4) Survey of MesoAmerican settlement prior to the arrival of the Europeans, including origins of the first hunters and gatherers, development of agriculture, Olmec and Zapotec civilizations, rise and fall of Teotihuacan, and settlement and influence of Mayans, Toltecs, and Aztecs up to the arrival of the Spanish.

ANTH 360 Indians of North America (4) Description and analysis of traditional native American cultural areas and impact of modern society on native Americans. *Preq. ANTH 250*

ANTH 399 Topics in Anthropology (1-4) Individual or small-group study, under the supervision of instructor, of topics not otherwise available to students.

Art History

ARTH 101 Introduction to Art (4) Beginning study of the nature and purposes of art as seen both in historical and contemporary works (primarily for non-art majors). GEP

ARTH 261 Art History Survey 1 (Prehistoric through Roman) (4) Covering Paleolithic, Egyptian, Near Eastern, Aegean, Greek, Etruscan, and Roman art.

ARTH 262 Art History Survey 2 (Medieval through Renaissance) (4) Study of Early Christian, Byzantine, Romanesque, Gothic, and Renaissance art.

ARTH 263 Art History Survey 3 (Baroque through Modern) (4) Study of Baroque, Neoclassical, Romantic, Realist, Impressionist, Post Impressionist, and Twentieth Century art.

ARTH 310 - ARTS 101

ARTH 310 History of Photography (4) Survey of major figures and ideas involved in the evolution of photography as a creative art form.

ARTH 331 Ceramic History Survey 1 (4) Prehistoric to modern non-Asian, including Egypt, Pre-Columbian American, Middle East, Africa, Europe, U.S.A.

ARTH 332 Ceramic History Survey 2 (4) Asia, China, Korea, Japan, Vietnam, and India.

ARTH 360 Nineteenth-Century Art (4) Study of the visual arts in Europe and America, from Neoclassicism through Postimpressionism, in relation to social and cultural developments of that time.

ARTH 361 Twentieth-Century Art (4) Comparative study of developments in all fields of visual art as expressions of our time.

ARTH 364 North American Survey (4) A survey of American art (colonial through the present). Discerning the reciprocal influences of the arts and their cultural, social, and historical contexts. Distinguishing the individual and common characteristics of artistic expression in their histories, styles, and traditions. Perceive the relationships among the arts disciplines and other forms of cultural expression.

ARTH 366 Non-Western Survey (4) A survey of non-Western art: Asia, China, Korea, Japan, Vietnam, and India. Discerning the reciprocal influences of the arts and their cultural, social, and historical contexts. Distinguishing the individual and common characteristics of artistic expression in their histories, styles, and traditions. Perceive the relationships among the arts disciplines and other forms of cultural expression. *GEP* *Preq. ENGL 115S*

Art Pedagogy

ARTP 201 Art in the Curriculum (3) Required of those who wish to become licensed teachers in Ohio in early childhood, early childhood intervention specialist, and intervention specialist—mild to moderate: K-12. The emphasis of the course is to teach the teacher to become a creative coach or a catalyst in the child's artistic growth. Emphasis is on understanding, facilitating, and integrating art into the curriculum. *Preq. EDUC 115; \$ FA*

ARTP 401 Studio Methods for Early Childhood (4) First of three arts pedagogy courses required for a multiage teaching license in visual arts. This course covers issues related to art as a subject matter, student learning, the diversity of learners in the visual arts, planning instruction, instructional strategies, learning environments, communication, assessment, professional development, and student support for students from pre-K through grade 3. *Preq. admission to teacher licensure program*

ARTP 402 Studio Methods for Middle Childhood (4) Second of three arts pedagogy courses required for a multiage teaching license in visual arts. This course covers issues related to art as a subject matter, student learning, the diversity of learners in the visual arts, planning instruction, instructional strategies, learning environments, communication, assessment, professional development, and student support for students from grades 4-9. *Preq. ARTS 101, 102, 103, and permission; preq./coreq. ARTP 401, 403, EDVA 485, and admission to teacher licensure program*

ARTP 403 Studio Methods for Adolescents and Young Adults (4) Third of three arts pedagogy courses required for a multiage teaching license in visual arts. This course covers issues related to art as a subject matter, student learning, the diversity of learners in the visual arts, planning instruction, instructional strategies, learning environments, communication, assessment, professional development, and student support for students from grades 7-12. *Preq./coreq. ARTP 401, 402, EDVA 485, and admission to teacher licensure program*

Arts

ARTS 101 Studio Foundations 1 (4) An entry-level class focusing on the dynamics of black and white, two-dimensional media. It provides students with methods of seeing, visualizing, and expressing themselves on paper. Required of all students with BFA major. *\$ FA*

ARTS 102 Studio Foundations 2 (4) An entry-level class which focuses on the use and perception of color. Discussion of various color systems. Color exercises based on theory and historic contexts. Required of all students with BFA major. \$ FA

ARTS 103 Studio Foundations 3 (4) An entry-level course devoted to the concepts and use of three-dimensional materials used in sculptural terms. Required of all students with BFA major. \$ FA

ARTS 105 The Creative Process (4) Interdisciplinary studies of the nature of creativity and the techniques used to promote creative thinking. Class discussions, exercises and experiments, along with video resources, guest speakers, and ongoing studio projects are employed to enhance students' personal and professional resourcefulness. Required for all BFA students.

ARTS 106 Digital Foundations (4) An introduction to the Macintosh operating system, peripherals, and storage of graphic-based work. Discussion of bit-mapped vs. vector graphics and their strengths and weaknesses. A broad overview of some of the software and the parameters it defines for the artist. Production of original artworks. *Preq. ARTS 101, 102, or permission; \$ FA*

ARTS 205 Graphic Design Reproduction Techniques (4) A course designed to familiarize the graphic design student with the various methods of reproducing the finished art work. Discussion of various methods of printing, color separation, and electronic media. Lectures, demonstrations, field trips, and studio work are included. \$ FA

ARTS 210 Photography 1 (4) An introduction to the art and techniques of photography. Student must provide 35mm camera. \$ FA

ARTS 211 Photography 2 (4) Continued exploration of photographic techniques. Student must provide 35mm camera. *Preq. ARTS 210; \$ FA*

ARTS 212 Photography 3 (4) Continuation of ARTS 211. Student must provide 35mm camera. *Preq. ARTS 211; \$ FA*

ARTS 215 Photography for the Graphic Designer (4) An introduction to the basic knowledge of photography for the graphic designer, covering the basics of setting up, lighting, and designing photo compositions. \$ FA

ARTS 221 Painting 1 (4) A focus on individual expression through the use of oil and acrylic painting mediums. *Preq. ARTS 101, 102, or permission; \$ FA*

ARTS 222 Painting 2 (4) Continuation and expansion of ideas developed in ARTS 221. *Preq. ARTS 221; \$ FA*

ARTS 223 Painting 3 (4) Extension of the concepts developed in ARTS 222. *Preq. ARTS 222; \$ FA*

ARTS 231 Ceramics 1 (4) Entry-level course focusing on the use of clay in creating hand built pottery and forms. Basics of glazing work are covered. \$ FA

ARTS 232 Ceramics 2 (4) Entry-level course focusing on the use of the potter's wheel to create basic thrown forms. \$ FA

ARTS 233 Ceramics 3 (4) Concentration on the combination of hand built and wheel thrown forms and further study of glaze techniques. *Preq. ARTS 231 and 232; \$ FA*

ARTS 238 Wood Design 1 (4) This course explores the basis for using wood as a design/sculpture medium. Initial understanding of tool use and safety practices is the focal point of this first class. \$ FA

ARTS 239 Wood Design 2 (4) Extension of ARTS 238. Students having a solid background in the use of woodworking tools concentrate on achieving aesthetic/artistic results in their individual design projects. \$ FA

ARTS 240 Wood Design 3 (4) Extension of ARTS 239. Promotes further exploration of the medium. \$ FA

ARTS 241 - ARTS 294

ARTS 241 Sculpture 1 (4) Course designed to develop the student's ability to conceive and build three-dimensional forms in various media (plaster, clay, wood, and metal). Understanding of shapes and mass, acquaintance with tools, techniques, and materials for expression. \$ FA

ARTS 242 Sculpture 2 (4) Intermediate sculpture course designed to further a student's skill in three-dimensional work. Technical procedures include advanced woodcarving, clay molding, stone carving, and various direct over armature methods. *Preq. ARTS 241; \$ FA*

ARTS 243 Sculpture 3 (4) Studio problems based on concepts applied to various three-dimensional materials. Advanced sculpture places special emphasis on the development of individual expression in the student's chosen medium. *Preq. ARTS 242; \$ FA*

ARTS 244 Introduction to Printmaking (4) A studio course utilizing basic techniques in relief printing and screen printing. \$ FA

ARTS 245 Intaglio (4) Introduction to basic intaglio techniques. Emphasis on mastering techniques used to develop personal imagery. *Preq. ARTS 101 and 102; \$ FA*

ARTS 246 Lithography (4) An introduction to basic lithographic technique and printing. Emphasis is placed on mastering techniques used to further personal aesthetic goals. *Preq. ARTS 101 and 102; \$ FA*

ARTS 247 Screen Printing (4) An introduction to basic silk screen techniques. Emphasis is on mastering techniques used to develop personal imagery. *Preq. ARTS 101 and 102; \$ FA*

ARTS 248 Relief Printing (4) An introductory course employing the range of graphic possibilities in the relief printing process. *Preq. ARTS 101 and 102; \$ FA*

ARTS 251 Typography for the Graphic Designer (4) Studio course beginning with some basic background in type design and theory and working through its use in modern graphic design. Use of transfer lettering, type sizing, and specifications in graphic design. \$ FA

ARTS 252 Basic Illustration (4) Studio course beginning with design basics and integrating these basics into illustration techniques for the graphic designer. Black and white graphics and color techniques. \$ FA

ARTS 253 Illustration (4) Extension of ARTS 252. The instructor helps the student develop a portfolio. *Preq. ARTS 252; \$ FA*

ARTS 271 Life Drawing 1 (4) Drawing from a model in black and white media. Repeatable for credit—maximum of two quarters. *Preq. ARTS 101 or permission; \$ FA*

ARTS 272 Life Drawing 2 (4) Continuation of ARTS 271. Repeatable for credit—maximum of two quarters. *Preq. ARTS 271; \$ FA*

ARTS 273 Life Drawing 3 (4) Continuation of ARTS 272. Repeatable for credit—maximum of two quarters. *Preq. ARTS 272; \$ FA*

ARTS 275 Drawing 1 (4) Extension of ARTS 101 and 102. Focus is on developing drawing skills (perspective, composition, etc.) through the use of colored pencils and advanced black and white media. *Preq. ARTS 101 and 102; \$ FA*

ARTS 276 Drawing 2 (4) Continuation of ARTS 275. Students are expected to demonstrate increased facility and conceptualization. *Preq. ARTS 275; \$ FA*

ARTS 277 Drawing 3 (4) A continuation of concepts developed in ARTS 275 and ARTS 276. *Preq. ARTS 276; \$ FA*

ARTS 292 Fabric Design 1 (4) Printing and dyeing fabric as well as applying design to cloth. \$ FA

ARTS 293 Fabric Design 2 (4) Continuation of ARTS 292. *Preq. ARTS 292; \$ FA*

ARTS 294 Fabric Design 3 (4) Continuation of ARTS 293. *Preq. ARTS 293; \$ FA*

- ARTS 299 Topics in Art (1-4)** Opportunity for the student to plan and complete a project which meets with the approval of the staff member supervising this arranged course. Repeatable for credit. *Preq. permission of staff*
- ARTS 310 Intermediate Photography 1 (4)** Continuation of ARTS 212 utilizing more advanced dark room and camera techniques. *Preq. ARTS 212; \$ FA*
- ARTS 311 Intermediate Photography 2 (4)** Utilizes techniques taught in ARTS 310 with emphasis on artistic growth in the medium. *Preq. ARTS 310; \$ FA*
- ARTS 312 Intermediate Photography 3 (4)** Utilizes techniques taught in ARTS 311. Individualizes instruction promoting continued artistic growth in the medium. *Preq. ARTS 311; \$ FA*
- ARTS 313 Media Photography (4)** Includes study, practice, and discussion of the function and production of photography in newspapers, video, magazines, ads, and publications. Emphasis on photographing public figures (portraits), sports and live action, and night shooting. An effort is made to show the coordination of words and pictures. Students must bring a 35 mm camera, film, and enlarging paper. Digital cameras are shared in class. *Preq. ARTS 210 and 211; \$ FA*
- ARTS 321 Intermediate Painting 1 (4)** Oil and acrylic painting used to extend concepts developed in earlier painting courses. Individual concepts highly stressed. *Preq. ARTS 223; \$ FA*
- ARTS 322 Intermediate Painting 2 (4)** *Preq. ARTS 321; \$ FA*
- ARTS 323 Intermediate Painting 3 (4)** *Preq. ARTS 322; \$ FA*
- ARTS 324 Watercolor 1 (4)** Series of courses which focuses on the use of transparent watercolors to extend personal imagery. *Preq. ARTS 101, 102, or permission; \$ FA*
- ARTS 325 Watercolor 2 (4)** Continuation of ARTS 324. *Preq. ARTS 324; \$ FA*
- ARTS 326 Watercolor 3 (4)** Continuation of ARTS 325. *Preq. ARTS 325; \$ FA*
- ARTS 327 Figure Painting 1 (4)** Painting the human figure from a model in oil or acrylic. *Preq. ARTS 223; \$ FA*
- ARTS 328 Figure Painting 2 (4)** Continuation of ARTS 327. *Preq. ARTS 327; \$ FA*
- ARTS 329 Figure Painting 3 (4)** Continuation of ARTS 328. Emphasis on individual style and technique as opposed to strictly objective rendering. *Preq. ARTS 328; \$ FA*
- ARTS 331 Intermediate Ceramics 1 (4)** Intermediate hand built techniques, including use of clay and glazes. A continuation of ARTS 231. *Preq. ARTS 231; \$ FA*
- ARTS 332 Intermediate Ceramics 2 (4)** Intermediate throwing techniques, including decorative techniques. *Preq. ARTS 232; \$ FA*
- ARTS 333 Intermediate Ceramics 3 (4)** A continuation of concepts developed in ARTS 233. *Preq. ARTS 233; \$ FA*
- ARTS 334 Raku Ceramics (4)** Introduction to the philosophy and techniques of the traditional Japanese ceramic ware called "Raku." *Preq. ARTS 231 or 232; \$ FA*
- ARTS 335 Porcelain Ceramics (4)** For advanced students of the potter's wheel. History, use, and glazing of porcelain. *Preq. permission of staff; \$ FA*
- ARTS 336 Glaze Theory and Practice (4)** Understanding of the many standard types of ceramic glazes. *\$ FA*
- ARTS 337 Tile Making (4)** Enhances the student's knowledge of historical and contemporary tile while enriching their ability to work with a variety of forms and mounting techniques. Students will use the elements and principles of design to create original tile work and foster critical thinking within group and individual forums. *\$ FA*
- ARTS 338 Mold Making (4)** History and development of ceramic mold making. Techniques to be addressed: bisque molds, press molds, sprigging, jigger and jolley processes, casting, ram pressing, and plaster technology.

ARTS 339 - ARTS 376

- ARTS 339 Low-Fire Ceramics (4)** History, development, and techniques of low-fire ceramics. Topics to be addressed: majolica glazed ware, terra sigillatas, and primitive smoking techniques. *Preq. ARTS 231 or 232; \$ FA*
- ARTS 341 Intermediate Sculpture 1 (4)** Techniques of sculptural expression in the “additive” mode: clay, wax, found elements. *Preq. ARTS 243; \$ FA*
- ARTS 342 Intermediate Sculpture 2 (4)** Experience with low and high relief sculpture in “subtractive” processes: carving and sandblasting in glass, clay, wood, stone, plastics. *Preq. ARTS 341; \$ FA*
- ARTS 343 Intermediate Sculpture 3 (4)** Relief and small full-round sculpture by casting processes: soft metals, plaster, plastics. *Preq. ARTS 342; \$ FA*
- ARTS 345 Intermediate Intaglio (4)** Continuation of ARTS 245. Intermediate level techniques in etching and plate production combined with use of printing papers in producing an individualized image. *Preq. ARTS 245; \$ FA*
- ARTS 346 Intermediate Lithography (4)** Continuation of ARTS 246. Individual styles and techniques in lithography and advances by understanding more advanced methods of register paper ink use. *Preq. ARTS 246; \$ FA*
- ARTS 347 Intermediate Screen Printing (4)** Continuation of ARTS 247. Introduction of new techniques in manual and photo screen print production. *Preq. ARTS 247; \$ FA*
- ARTS 355 Visualist Studio 1 (4)** Must be taken three times for credit. Students in this course work on an individual basis by “contracting” with their instructor to complete a given number of design/imaging projects using hand drawn and software (from the 360/460 series) generated methods. Studio experience should lead to portfolio pieces. *Preq. must have completed first Visualist elective group or permission; \$ FA*
- ARTS 361 Digital Publishing and Layout (4)** May be taken three times for credit. This course is designed to develop a student’s ability to use software such as QuarkXPress to bring together graphic elements (photos, images, illustrations) and text into a finished design product. Students learn how to manipulate type elements in a design as well as produce documents which are ready for the printer or publication. *Preq. ARTS 106 or permission; \$ FA*
- ARTS 362 Digital Imaging (4)** May be taken three times for credit. Students learn to create and manipulate graphics and images using bit-mapped digital programs such as Adobe Photoshop to accommodate their effective use in design and imaging processes. *Preq. ARTS 101, 102, or permission; \$ FA*
- ARTS 363 Digital Illustration/Type (4)** May be taken three times for credit. This course uses vector based software such as Macromedia Freehand (an ideal source for work on the internet) to create original works of art, illustration, and work in type. *Preq. ARTS 106 or permission; \$ FA*
- ARTS 364 Digital Paint (4)** May be taken three times for credit. This course presents the use of paint software, such as Painter, to create original digital artwork that mimics traditional art media, such as oils, charcoal, pencil, watercolor, and airbrush. It also mimics art surfaces, such as watercolor paper, canvas, and glass. *Preq. ARTS 106 or permission; \$ FA*
- ARTS 371 Intermediate Life Drawing 1 (4)** Working from a model developing a unique personal approach to drawing. Repeatable for credit—maximum of two quarters. *Preq. ARTS 101; \$ FA*
- ARTS 372 Intermediate Life Drawing 2 (4)** Continuation of ARTS 371. Repeatable for credit—maximum of two quarters. *Preq. ARTS 101; \$ FA*
- ARTS 373 Intermediate Life Drawing 3 (4)** Continuation of ARTS 372. Repeatable for credit—maximum of two quarters. *Preq. ARTS 101; \$ FA*
- ARTS 375 Intermediate Drawing 1 (4)** Development of a personal style of expression in two-dimensional drawing mediums. *Preq. ARTS 277; \$ FA*
- ARTS 376 Intermediate Drawing 2 (4)** Continuation of ARTS 375. *Preq. ARTS 375; \$ FA*

- ARTS 399 Topics in Art (1-4)** Opportunity for the student to plan and complete a project which meets with the approval of the staff member supervising this arranged course. Repeatable for credit. *Req. permission of staff*
- ARTS 410 Advanced Photography 1 (4)** Advanced techniques in individualized areas such as lighting, color, and photographing the figure. *Req. ARTS 312; \$ FA*
- ARTS 411 Advanced Photography 2 (4)** Continuation of ARTS 410. *Req. ARTS 410; \$ FA*
- ARTS 412 Advanced Photography 3 (4)** Continuation of ARTS 411 and presentation of senior portfolio. *Req. ARTS 411; \$ FA*
- ARTS 421 Advanced Painting 1 (4)** *Req. ARTS 326; \$ FA*
- ARTS 422 Advanced Painting 2 (4)** *Req. ARTS 421; \$ FA*
- ARTS 423 Advanced Painting 3 (4)** Focus on helping the artist develop a coherent/cohesive body of work (developing an individual style). *Req. ARTS 422; \$ FA*
- ARTS 424 Advanced Watercolor 1 (4)** Continuation of ARTS 326 with more emphasis on individual style and use of more advanced materials such as special papers, etc. *Req. ARTS 326; \$ FA*
- ARTS 425 Advanced Watercolor 2 (4)** Continuation of ARTS 424 with a widening dialog of expression based on individual style. Combined with experiments in the medium. *Req. ARTS 424; \$ FA*
- ARTS 426 Advanced Watercolor 3 (4)** Continuation of ARTS 425 combined with a presentation of senior portfolio. *Req. ARTS 425; \$ FA*
- ARTS 427 Advanced Figure Painting 1 (4)** Painting from a model in oil or acrylic. *Req. ARTS 329; \$ FA*
- ARTS 428 Advanced Figure Painting 2 (4)** Painting from a model in oil or acrylic. *Req. ARTS 427; \$ FA*
- ARTS 429 Advanced Figure Painting 3 (4)** Continuation of ARTS 428. Considerable progress in a personal style is encouraged with emphasis on using the human form as a basis for advanced work. *Req. ARTS 428; \$ FA*
- ARTS 434 Advanced Raku (4)** Continuation of ARTS 334. The Raku philosophy as applied to modern and western forms. *Req. permission of staff; \$ FA*
- ARTS 435 Advanced Porcelain (4)** Continuation of ARTS 335. Commercial and self-formulated glazes. Both larger thrown works and hand-built forms.
- ARTS 436 Advanced Glaze Theory and Practice (4)** Continuation of ARTS 336. Compounding and testing of self-designed glazes. *Req. ARTS 336; \$ FA*
- ARTS 441 Advanced Sculpture 1 (4)** Techniques of casting in full-round, high-temperature, "harder" metals (bronze, aluminum) using the cire perdue process. *Req. ARTS 343; \$ FA*
- ARTS 442 Advanced Sculpture 2 (4)** Emphasizes personal expression and the development of style in combinations of the foregoing technical processes. *Req. ARTS 441; \$ FA*
- ARTS 443 Advanced Sculpture 3 (4)** Continuation of personal development. Introduction to land art, monument art, environment art, happenings, performance art. *Req. ARTS 442; \$ FA*
- ARTS 455 Visualist Studio 2 (4)** Must be taken three times for credit. This course allows students to work on projects using many different software programs as well as board produced art. It is meant to closely replicate the work environment where individuals or teams of artists work to solve creative problems. Work in this sequence should be portfolio presentation level. An approved co-op experience may be substituted for up to 12 credit hours of class work in this sequence. *Req. ARTS 355 or permission; \$ FA*

ARTS 459 - BIOL 162

ARTS 459 Arts Internship (6-12) Approved employment of 40 hours per week for a minimum of 10 weeks for 12 credits. Must produce portfolio-presentation-level work in professional work environment using a variety of software programs. This approved co-op experience may be substituted for 12 credit hours of ARTS 455. Twenty to thirty-nine hours per week of work may be granted six credit hours over a ten-week period. *Preq. ARTS 355 or 455; 20 or 40 lab*

ARTS 465 Digital 3-D (4) May be taken three times for credit. This course concentrates on the use of 3-D programs, such as Studio Pro 3-D, to create original art, illustrations, images for animation, and interactive CDs. *Preq. ARTS 362 or permission; \$ FA*

ARTS 466 Interactive Scripting (4) May be taken three times for credit. This course focuses on creating finished art using software which facilitates digital scripting (combining music, voice, video, animation, graphics, and photography) into a finished video or interactive CD. *Preq. ARTS 362, 363, or permission; \$ FA*

ARTS 467 Website Arts (4) May be taken three times for credit. This course focuses on creating finished art using software, such as Adobe Sitemill or Macromedia Dreamweaver, to create website designs (combining music, voice, video, animation, graphics, and photography). *Preq. ARTS 362, 363, or permission; \$ FA*

ARTS 475 Advanced Drawing 1 (4) Continuation of ARTS 376. *Preq. ARTS 376; \$ FA*

ARTS 476 Advanced Drawing 2 (4) Continuation of ARTS 475. *Preq. ARTS 475; \$ FA*

ARTS 480 Senior Studio 1 (4) This course (and ARTS 481) must be taken the senior year in the area of the student's concentration. Arranged time. *\$ FA*

ARTS 481 Senior Studio 2 (4) This course must be in the area of the student's concentration. Arranged time. *Preq. ARTS 480; \$ FA*

ARTS 499 Topics in Art (1-4) Opportunity for the student to plan and complete a project which meets with the approval of the staff member supervising this arranged course. Repeatable for credit. *Preq. permission of staff; \$ FA*

Biology

BIOL 099 Fundamental Biology (4) Designed for students with an inadequate background in biological science or those students with no high school biology who plan to enter one of the allied health programs. Material presented is intended to increase familiarity with terms and chemical processes.

BIOL 101 Introduction to Biology (3) An introduction to basic concepts of biology for health sciences students. Biology credit is given for either—but not both—BIOL 101 or 151, which are introductory courses.

BIOL 130 Principles of Anatomy and Physiology 1 (5) An introduction to basic concepts of biology and the anatomy and physiology of skeletal, muscular, nervous, and digestive systems. Biology credit is allowed for only *one* of the following sequences: BIOL 130 and 131; BIOL 101, 151, and 162; or BIOL 310 and 320. *4 lec. 2 lab; \$ NS*

BIOL 131 Principles of Anatomy and Physiology 2 (5) An introduction to the anatomy and physiology of the respiratory, cardiovascular, renal, and reproductive systems. Biology credit is allowed for only *one* of the following sequences: BIOL 130 and 131; BIOL 101, 151, and 162; or BIOL 310 and 320. *4 lec. 2 lab; \$ NS*

BIOL 151 Principles of Biology (5) Introduction to principles and concepts of life; emphasis on interrelationships of structural, functional, reproductive, evolutionary, and ecological principles related to cells and organisms. Biology credit is given for either—but not both—BIOL 101 or 151, which are introductory courses. *GEP 4 lec. 2 lab; \$ NS*

BIOL 162 Human Anatomy and Physiology (5) A general survey of the structure and function of the human body. Biology credit is given for either—but not both—BIOL 162 or 310, which are introductory courses. Not applicable for students requiring BIOL 310 and BIOL 320. *Preq. BIOL 101 or 151; 4 lec. 2 lab; \$ NS*

- BIOL 202 Principles of Plant Biology (5)** Anatomy and morphology of seed plants are related to the functional aspects of photosynthesis, growth, transport, and reproduction. Practical emphasis on plant/man interactions. Brief survey of plant kingdom with focus on life histories and evolutionary relationships. *Preq. BIOL 151; 4 lec. 2 lab; \$ NS*
- BIOL 203 Principles of Animal Biology (5)** Principles of animal taxonomy, structure, function, development, and behavior. Laboratory survey of major phyla. *Preq. BIOL 151; 4 lec. 3 lab; \$ NS*
- BIOL 210 Taxonomy of Vascular Plants (4)** Principles of classification of extinct and extant seed plants with emphasis on family recognition. Collection, identification, and preservation of seed plants. *GED 3 lec. 2 lab; \$ NS*
- BIOL 212 Forestry Management and Practices (4)** Investigation of the development and the existing practices of modern forestry in the U. S. Basic management practices are discussed with laboratory exercises designed to improve forest management skills. *Preq. BIOL 202; 3 lec. 2 lab; \$ NS*
- BIOL 220 Wildlife Management (4)** A study of ecological principles of the management of wild animals, both game and non-game species. The economic importance of wildlife and the role of various wildlife agencies are also considered. *3 lec. 2 lab; \$ NS*
- BIOL 271 Field Ornithology (4)** A study of the classification, adaptation, and habitat requirements of birds with particular emphasis on Ohio species. Field identification is emphasized in lab. *GED 3 lec. 3 lab; Saturday field trip; \$ NS*
- BIOL 290 Seminar in Life Sciences (1-4)** Discussion of advanced topics in the life sciences.
- BIOL 302 Dendrology (4)** Collection, identification, nomenclature, classification, and ecological relationship of native, introduced, and cultivated woody plants. *GED 3 lec. 2 lab; \$ NS*
- BIOL 303 Spring Flora (4)** Identification, nomenclature, and classification of spring flowering plants. Origin and evolution of flora in Ohio. *GED 3 lec. 2 lab; \$ NS*
- BIOL 307 General Entomology (5)** An introduction to the morphology and classification of insects. The major orders, families, and species of economic importance, both beneficial and pest, are emphasized. Students collect and identify local species. *GED 4 lec. 2 lab; \$ NS*
- BIOL 310 Principles of Anatomy (5)** An introduction to morphology of tissues and systems of the human body. Biology credit is given for either—but not both—BIOL 162 or 310, which are introductory courses. *Preq. BIOL 101 or 151; 4 lec. 3 lab; \$ NS*
- BIOL 311 Kinesiology (4)** Concentration on skeletal and muscle systems and their functional interplay in the analysis of motion. *Preq. BIOL 131, 162, or 310; 3 lec. 2 lab; \$ NS*
- BIOL 312 Sectional Anatomy (3)** An introduction to sectional human anatomy. *Preq. BIOL 162 or 310; 2 lec. 2 lab; \$ NS*
- BIOL 314 Human Neuroanatomy (5)** A detailed anatomy of the human nervous system with attention to functional and clinical considerations. *Preq. BIOL 131, 162, or 310; 4 lec. 2 lab; \$ NS*
- BIOL 315 Histology (5)** Study of the microscopic structure of cells, tissues, and organ systems and their physiological properties. *Preq. BIOL 162 or 310; 4 lec. 2 lab; \$ NS*
- BIOL 320 Principles of Physiology (5)** An introduction to human systems physiology. *Preq. BIOL 162 or 310*
- BIOL 321 Physiology Lab (2)** Laboratory designed to complement BIOL 320. Exercises illustrate basic principles and techniques of animal physiology. By instructor permission only. *Preq./coreq. BIOL 320; 1 discussion 3 lab; \$ NS*
- BIOL 325 Pathophysiology (5)** An investigative study of the physiological changes caused by diseases and their pathological outcomes. *Preq. BIOL 131 or BIOL 320*

BIOL 330 - BIOL 432

BIOL 330 Ecology (5) A study of the interrelationships among the many elements in an environment. A historical approach to the concept of evolution, man's impact upon the environment, and common ecological problems faced by society. Labs introduce common and basic ecological techniques. *Preq. BIOL 202; 4 lec. 2 lab; Saturday field trip; \$ NS*

BIOL 331 Advanced Field Biology (4) Examination of the principles and techniques of biological field investigation. *Preq. BIOL 330; 3 lec. 3 lab; Saturday field trip; \$ NS*

BIOL 340 Genetics (5) Principles and concepts of genetics as revealed by classical and modern investigation. Transmission, molecular, and population genetics are examined. *Preq. BIOL 151 and CHEM 122 or 142*

BIOL 341 Genetics Lab (2) Experiments and experiences designed to illustrate principles of genetics. *Preq./coreq. BIOL 340; 4 lab; \$ NS*

BIOL 350 Microbiology (5) A survey of representative types of microorganisms. Emphasis is placed on cellular structure and physiology, nutritional, and environmental requirements, and methods of reproduction. Introduction to the role of pathogenic organisms in diseases, principles of immunity, and resistance to disease. Laboratory includes methods of sterilization, culturing, staining, and identification of bacteria. *Preq. BIOL 101, 130, or 151; 4 lec. 3 lab; \$ NS*

BIOL 360 Plant Anatomy and Morphology (5) Detailed study of vascular plant anatomy and morphology considered from an evolutionary viewpoint. Labs involve study of anatomy and morphology of all major vascular plant groups, extinct and extant. *Preq. BIOL 202; 4 lec. 2 lab; \$ NS*

BIOL 365 Phycology (5) An introduction to the taxonomy, morphology, evolution, and ecology of terrestrial, freshwater, and marine algae. Practice in identifying local species. *Preq. BIOL 151; 4 lec. 2 lab; \$ NS*

BIOL 370 Marine Biology (5) An introduction to marine biology, including the areas of oceanography and ecology. All biological principles are infused into discussions with marine themes. *Preq. BIOL 151; 4 lec. 2 lab; \$ NS*

BIOL 395 Special Topics in Biology (1-4) Individual or small-group study, under the supervision of instructor, of topics not otherwise available to students. *\$ NS*

BIOL 405 Animal Behavior (5) Study of patterns of animal behavior including ecological, physiological, and developmental mechanisms which regulate their formation and occurrence. *Preq. BIOL 203 or permission; 4 lec. 3 lab; \$ NS*

BIOL 407 Pathogenic Bacteriology (5) A study of the morphological, cultural, biochemical, and serological characteristics of various pathogenic bacteria. Emphasis on virulence factors and host-pathogen interaction. *Preq. BIOL 350; 3 lec. 6 lab; \$ NS*

BIOL 408 Virology (4) A study of the structure, replication strategies, pathogenesis, epidemiology, and control of bacteriophage, animal, and plant viruses with special emphasis on those causing human disease. *Preq. BIOL 101 or 151*

BIOL 410 Advanced Human Anatomy (5) A regional approach to the anatomy of the human body utilizing cadaver dissection. *Preq. BIOL 131, 162, or 310; 4 lec. 3 lab; \$ NS*

BIOL 411 Biochemistry (4) General principles of the structural and functional properties of carbohydrates, lipids, nucleic acids, and proteins. This course counts in a B.S.N.S. concentration area in either biology or chemistry. *Preq./coreq. CHEM 307; 4 lec.*

BIOL 420 Mammalogy (5) A study of the structural features, evolution, and classification of mammals, especially of Ohio. Other topics include ecology, zoogeography, behavior, reproductive strategies, physiological adaptations to extreme environments, and economic aspects. *Preq. BIOL 151 or equivalent; 4 lec. 3 lab; \$ NS*

BIOL 432 Cell Biology (5) Current survey of the structure and function of eukaryotic and prokaryotic cells, including recent advances in molecular biology and tissue culture technique. *Preq. BIOL 340*

BIOL 440 Molecular Biology (5) A study of gene structure and function at the molecular level with an emphasis on modern techniques for gene analysis and manipulation, including cloning, sequencing, genomics, molecular probes, mutagenesis, and bioinformatics. *Req. BIOL 340; 3 lec. 6 lab \$ NS*

BIOL 450 Immunology (5) Study of antigen and antibodies with emphasis on in vivo and in vitro reactions, including recent information in immunogenetics and monoclonal strategies. *Req. BIOL 350; 4 lec. 3 lab \$ NS*

BIOL 470 Plant Physiology (5) A general introduction, including plant/soil, plant/water relationships, mineral nutrition, photosynthesis, and growth integrated with related aspects of biophysics. *Req. BIOL 202 and 360; 4 lec. 2 lab; \$ NS*

BIOL 485 Senior Project (1-4) In-depth study of a selected topic in the life sciences, culminating in the preparation of a senior paper. By instructor permission only. *Req. junior or senior standing; \$ NS*

BIOL 490 Seminar in the Life Sciences (1-4) Discussion of advanced topics in the life sciences. *Req. junior or senior standing*

BIOL 495 Undergraduate Research (1-4) Independent life science investigation under the direction of a faculty member. A maximum of six credit hours of BIOL 495 may be counted as biology electives or concentration. By instructor permission only. *Req. junior or senior standing; \$ NS*

BIOL 499 Special Topics in Life Science (1-4) Individual or small-group study, under the supervision of instructor, of topics not otherwise available to students. *\$ NS*

Biomedical Sciences

BMSC 340 Medical Genetics (4) The study of genetics as it relates to medically significant variation and heredity in man. *Req. BIOL 350; \$ HS*

BMSC 411 Medical Biochemistry (4) A study of medically significant biochemical structure and reactions as they occur in living systems. *Req. BIOL 350 and CHEM 305; \$ HS*

BMSC 432 Molecular Biology (4) Basic molecular concepts and procedures used in the diagnosis and characterization of genetic disease and malignancy. *Req. BIOL 350; \$ HS*

BMSC 450 Medical Immunology (4) Study of the immune system, with special emphasis on immunologic methods used in medicine and immune-mediated diseases that are frequently diagnosed and evaluated by immunological methods. *Req. BIOL 350; \$ HS*

Bachelor of Science Nursing

SPECIAL NOTE: *Only those students officially accepted into the RN-BSN program or those with permission of the program chair may take courses with the BSNR prefix.*

BSNR 341 Transcultural Nursing (4) Focuses on the comparative study and analysis of different cultures and subcultures with respect to nursing and health/illness practices, beliefs, and values with the goal of using this knowledge to provide culture-specific and culture-universal nursing care. *Req. admission to BSN program or 2.5 GPA and learning goals of learner are compatible with goals of the course; \$ HS*

BSNR 342 Nursing Informatics (4) Provides the health professional with knowledge of how to use computer systems and their comprehensive communication technology in client care. Also helps the nurse manage information through computers. Legal and ethical issues related to information technology are considered. *\$ HS*

BSNR 343 Research and Decision Making in Nursing (4) The RN student is introduced to the essential knowledge and skills needed to critically review, evaluate, and utilize findings from research studies applicable to health care delivery and the care of clients. *Req. MATH 150 and junior level standing; \$ HS*

BSNR 345 - BUAC 103

BSNR 345 History, Theory, and Trends in Professional Nursing (4) Conceptual models and theories that guide professional nursing are described and applied to health care delivery as it exists in a variety of settings. Nursing history is presented as a frame of reference to changing trends in nursing and health care and from which registered nurse students are able to develop as professional nurses. *Preq. admission to program and junior level standing; \$ HS*

BSNR 363 Health Appraisal and Physical Assessment (4) Client health appraisal and physical assessment for the registered nurse. Focuses on developing nursing skills of obtaining a health assessment appraisal and completing a physical examination with clients across the life span. Integrative clinical laboratory experiences correlate didactic information and clinical skills. *Preq. consent of the instructor; 3 lec. 3 lab; \$ HS*

BSNR 451 Family Nursing in the Community (5) Concepts and applications of family theoretical frameworks to assess and intervene with families in the community. The RN student works with families in settings, including homes, schools, and ambulatory care clinics, applying holistic caring strategies to human needs and health delivery for families, women, and children in the role of provider of care, consumer advocate, and educator. *Preq. AHNR 354, BSNR 363; 3 lec. 6 lab*

BSNR 453 Leadership and Management in Nursing (5) Theories of leadership/management, organization, change, power, and the collaborative role of the professional nurse is explored based on trends in the health care system, practice in diverse health care environments, and with multidisciplinary teams. Relationships among quality improvement, financing, performance appraisal, and change are integrated into critical thinking and decision making processes. Research utilization as it relates to leadership and management is incorporated throughout the course. *Preq. senior level standing and BSNR 345; 4 lec. 3 lab; \$ HS*

BSNR 454 Community and Public Health Nursing (5) Concepts and principles of community and public health nursing and applications of health promotion and national health goals. The RN student works with aggregates in the community setting, collaboratively, as a member of a multidisciplinary team in the role of change agent, consumer advocate, educator, and consumer of research. The student uses skills in community assessment, program planning, and practice interventions to help identified populations within the community maintain their optimum level of health. *Preq. senior standing, BSNR 341 and 343; 3 lec. 6 lab; \$ HS*

BSNR 462 Innovations and Adaptations (6) Provides core knowledge regarding the unique characteristics and health care needs of individuals coping with chronic illnesses. Focuses on providing competent holistic care in a variety of settings. Includes exploration of complimentary/alternative therapies that could be useful in health promotion, disease/illness management, and healing efforts. *Preq. BIOL 325, BSNR 341, 354, and admission to the BSN program; 5 lec. 3 lab; \$ HS*

BSNR 495 Special Topics in Nursing (1-4) Individually designed and implemented study topic explored in depth by the RN student. Topics, learning methods, evaluation strategies, and credit hours are negotiated between the student and the faculty. *Preq. permission of the instructor; \$ HS*

Accounting

BUAC 101 Accounting 1 (4) Introduction to accounting concepts and procedures. The accounting cycle: nature of accounts and techniques of recording, classifying, summarizing, and analyzing basic financial data. Accounting for the formation and operation of business enterprises. *\$ B*

BUAC 102 Accounting 2 (4) Application of fundamental accounting techniques for cash, long term investments, notes and accounts, inventory methods, plant and equipment, and liabilities. Introduction to manufacturing operations, cost methods, and management's need of cost data. *Preq. BUAC 101; \$ B*

BUAC 103 Accounting 3 (4) Reporting and analyzing financial data. Financial statement introduction, analysis, and interpretation to meet the needs of modern management. Introduction to accounting techniques applicable to parent and subsidiary companies and departmental and branch operations. Budgeting as an aid to management and the importance of income tax considerations in financial decisions. *Preq. BUAC 102; \$ B*

BUAC 110 Payroll Records/Accounting (4) A basic course in the maintenance of personnel and payroll records as required by the Fair Labor Standards Act and the various federal and state laws covering the withholding and payment of payroll related taxes. *Preq. BUAC 101; \$ B*

BUAC 201 Financial Accounting Principles (4) An introduction to the concepts and principles underlying financial accounting theory. The study includes the accounting equation and its application to the business entity. Procedures and concepts in accumulating and reporting financial information are developed. (Not open to students who have completed BUAC 101 and 102.) *Preq. sophomore standing; \$ B*

BUAC 203 Managerial Accounting (4) A study of the financial information needs of management for decision making. Includes the development of financial statements for manufacturing entities, the study of the components of unit cost, variable costing, and cost-volume-profit analysis. *Preq. BUAC 201; \$ B*

BUAC 215 Tax Accounting (4) Current income tax law and regulations related to business and individual income tax reporting. Practice in preparation of tax returns of businesses and individuals. *Preq. BUAC 103; \$ B*

BUAC 221 Cost Accounting 1 (4) Introduction to cost accounting systems and methods. Cost concepts, classifications, and measurement techniques in relation to their importance in determination, planning, and control. Job order and process cost accounting methods. *Preq. BUAC 103 or 203; \$ B*

BUAC 231 Intermediate Accounting 1 (4) A more advanced treatment of accounting theory; determination of income realization and cost expiration. Primary emphasis is on asset accounts in order listed on the balance sheet. *Preq. BUAC 103; \$ B*

BUAC 250 Accounting Projects 1 (1-4) A special course designed to permit the accounting student to work on special projects under the supervision of an instructor with expertise in the area of the student's project. The special projects course enables the accounting student to apply the accounting theory as covered in other courses. *Preq. departmental permission (see accounting advisor).*

BUAC 261 Microcomputer Accounting Systems (4) Application of basic accounting procedures to the microcomputer. *Preq. BUAC 103 or 203 and BUAI 101*

BUAC 299 Special Topics 1 (1-4) Opportunity for accounting students to continue their study of accounting in specialized areas under the supervision of an instructor with expertise in those areas. *Preq. departmental permission (see accounting advisor); see special note on page 131; \$ B*

BUAC 305 Governmental Accounting (4) A basic introduction to the accumulation and use of accounting information in non-profit organizations. General principles applying to budgets and funds are examined rather than specific application. An especially useful course for nonaccounting (and accounting) students who will be employed in governmental units where budgeting and accounting are required. *Preq. BUAC 103 and permission or BUAC 231; \$ B*

BUAC 311 Accounting Projects—Advanced (1-4) A special course designed to permit the advanced accounting student to work on special projects under the supervision of an instructor with expertise in the area of the student's project. The special projects course enables the accounting student to apply the accounting theory as covered in other courses. *Preq. BUAC 333 and departmental permission; \$ B*

BUAC 322 Advanced Cost Concepts (4) Estimating, planning, and controlling the costs of processes and projects. Standard cost accounting procedures and the analysis of variances. Cost and profit responsibility reporting to management. Uses of cost and profit data in project selection, product pricing, and other functions of management. *Preq. BUAC 221; \$ B*

BUAC 330 Industrial Accounting (4) Study of the use of data by management in planning and controlling business operations. Emphasis on the solution of problems confronting management by the use of accounting information in analytical form. *Preq. BUAC 103 or permission; \$ B*

BUAC 332 Intermediate Accounting 2 (4) Continuation of BUAC 231 with emphasis on the balance sheet sections dealing with investments, fixed assets, and liabilities. *Preq. BUAC 231; \$ B*

BUAC 333 - BUAI 299

BUAC 333 Intermediate Accounting 3 (4) Continuation of BUAC 332 with detailed study of the owner's equity section of the balance sheet and the financial statements presentation and analysis. *Preq. BUAC 332; \$ B*

BUAC 339 Special Problems in Financial Accounting (4) Continuation of financial accounting theory with application to special problems frequently encountered in business. Topics of study include business combinations, accounting for leases and casualty losses, accounting from incomplete records, and an introduction to partnership accounting. *Preq. BUAC 333*

BUAC 360 Systems Accounting (4) A course in accounting information systems principles and applications. The application of accounting principles to computerized environment, including transaction processing and internal controls, revenue and expenditure cycle applications, software systems, and computer security. *Preq. BUAI 101 and BUAC 103; \$ B*

BUAC 410 Health Care Accounting/Administration (4) The use of accounting information in planning and controlling the operations of health care organizations. budgeting and the specialized cost accounting applications of health care organizations are included. *Preq. BUAC 103; \$ B*

BUAC 431 Advanced Accounting 1 (4) A study of the modern complex corporate environment. Emphasis on accounting for corporate combinations and the special problems arising from mergers and acquisitions. *Preq. BUAC 221 and 333*

BUAC 433 Advanced Accounting 2 (4) A study of special applications of accounting systems and procedures such as foreign currency translation, home office and branch accounting, accounting for distressed entities, and partnership accounting. *Preq. BUAC 221 and 333*

BUAC 435 Auditing (4) Independent audits, professional ethics, legal liability, internal control, auditing standards, work sheet applications and procedures. Concern is given to audit evidence, the auditor's approach and techniques, summary reports, statistical sampling, and role of advisory services to management. *Preq. BUAC 322 and 333*

BUAC 499 Special Topics—Advanced (1-4) Opportunity for the advanced accounting student to continue the study of accounting in a specialized area of accounting under the supervision of an instructor with expertise in the area. *Preq. instructor permission (see accounting advisor); see special note on page 131; \$ B*

Automated Information Systems

BUAI 101 Computer Applications 1 (4) Introduces computer concepts within the framework of business applications. Emphasis is on developing word processing and presentation skills, using commonly accepted word processing and presentation applications software in a laboratory setting. *Preq. Knowledge of the fundamental computing process, components of the computing system, and basic computer terminology, plus minimum keyboarding skills of 20 wpm with 3 or fewer errors in a 3 minute timed writing. \$ B*

BUAI 102 Computer Applications 2 (4) Emphasizes the development and refinement of spreadsheet construction and manipulation, using commonly accepted spreadsheet and database applications software. *Preq. BUAI 101; \$ B*

BUAI 150 Internet and Web Publishing (4) A study of the Internet and its history, technology, applications, and uses. Includes lectures, discussion, and hands-on use of the Internet. *\$ B*

BUAI 201 IS Fundamentals, Theory, and Practice (4) Provides the basis for understanding major components of the discipline: information systems, planning and management, information technology, and organization systems, including ethical and legal issues related to IS. *Preq. BUAI 102*

BUAI 299 Special Topics in Automated Information Systems 1 (1-4) Opportunity for the student to work on special projects under the supervision of an instructor with expertise in the area of the student's project. *Preq. instructor permission; see special note on page 131; \$ B*

BUAI 301 Hardware/Software/Networking (4) Prepares the student to support personal computers and to study distributed computing. Includes lecture and hands-on work to learn how to handle various hardware, operating systems, and networking situations. \$ B

BUAI 303 Visual BASIC 2 (4) Second-level programming course in which students code and execute error-free programs in the Visual BASIC language. *Preq. BUIS 103; \$ B*

BUAI 310 Introduction to Database with SQL (4) Introductory course, covering how databases are constructed and used in organizations. SQL is studied from a user's view not a programming effort. *Preq. BUAI 102; \$ B*

BUAI 320 Systems Analysis and Design (4) Basic concepts and techniques used in the analysis, design, implementation, documentation, and evaluation of systems utilizing state-of-the-art technology. *Preq. BUAI 102*

BUAI 330 Object-Oriented Programming (4) Third-level programming course using Visual BASIC and the design techniques of an object-oriented, event-driven language. *Preq. BUIS 103 and BUAI 303; \$ B*

BUAI 350 Web Design (4) Examination of the effective creation of websites, dealing with issues such as international and special needs users. Lecture and hands-on instruction in the creation of viewer interactive web pages. *Preq. BUAI 150, equivalent, or permission*

BUAI 360 ASP.Net (4) Design and maintenance of interactive and dynamic Web applications within the server-based scripting environment of active server pages. *Preq. BUAI 303 and BUIS 103*

BUAI 370 E-Commerce (4) Language dependent upper-level course, covering electronic commerce. Addresses the similarities and differences between e-commerce and traditional business structures and explores some of the issues, concerns, and effective operation via lectures and case studies. *Preq. BUAI 102*

BUAI 421 Advanced Database (4) Advanced-level programming course, using Visual BASIC for the AD, involving input data editing, reports, database access using a windows form. *Preq. BUAI 303 and 330; \$ B*

BUAI 430 Information Systems Deployment and Management (4) Students engage in significant project with minimal supervision for a real or simulated client. Project includes determination of physical flows based on reengineering of functions, database, logical and physical design, functional analysis, development, conversion, and implementation design. Readings and discussion related to management of the IS function, systems integration, and project management to ensure project quality. *Preq. BUAI 320 or permission; \$ B*

BUAI 499 Special Topics in Automated Information Systems 2 (1-4) Opportunity for the advanced student to work on special projects under the supervision of an instructor with expertise in the area of the student's project. *Preq. instructor permission; see special note on page 131; \$ B*

Finance

BUFI 240 Personal Finance (4) Takes the student through the topics of financial planning, budgeting, housing, transportation, insurance, investments, retirement, and estate planning.

BUFI 245 Principles of Finance (4) A study of the forms of business organization, cash flow projections, budgeting and financial planning, and analysis of financial statements. (Not open to those who have completed BUFI 345.) *Preq. BUAC 102*

BUFI 250 Introduction to Investments (4) A study of the various types of investments, including stocks, bonds, mutual funds, commercial paper, options, and commodities. Particular emphasis is given to return and risk in developing investment strategies. (Not open to those who have completed BUFI 350.) *Preq. BUFI 245*

BUFI 299 Special Topics in Banking/Finance (1-4) Opportunity for the student to work on special projects under the supervision of an instructor with expertise in the area of the student's project. *Preq. instructor permission; see special note on page 131.*

BUFI 301 - BUHE 410

BUFI 301 Principles of Insurance (4) Basic insurance course includes the nature of risk; the legal environment; life, health, income, property liability, business risk, government, and international insurance.

BUFI 311 Financial Statement Analysis (4) A detailed study involving the analysis and interpretation of financial information contained in financial reports of various entities, including measurements of the firm's profitability, solvency, and degree of safety. *Preq. BUAC 103 or 203*

BUFI 315 Financial Institutions (4) An integrated and comprehensive analysis of financial markets and institutions emphasizing financial intermediaries and their operation in the markets. *Preq. BUAC 102 and ECON 201*

BUFI 345 Managerial Finance (4) An analysis of financial information for the purpose of facilitating the planning, organizing, and controlling functions of management. Includes financial statement analysis, budgeting, concepts of present and future value, cash flow analysis, and capital budgeting decisions. *Preq. BUAC 103 or 203, ECON 201, 202, and MATH 150*

BUFI 350 Investments (4) A study of various investment alternatives and the general and specific information that must be considered before thought is directed toward specific industries and businesses. Included is the study of the tools and sources needed for analysis in making wise investment decisions. *Preq. BUAC 102, BUFI 345, and ECON 201*

BUFI 499 Special Topics in Finance 2 (1-4) Opportunity for the junior or senior student to work on special projects under the supervision of an instructor with expertise in the area of the student's project. *Preq. instructor permission; see special note on page 131.*

Health Management

BUHE 299 Special Topics in Health Management (1-4) Opportunity for the student to work on special projects under the supervision of an instructor with expertise in the area of the student's project. *See special note on page 131.*

BUHE 300 Medical Terminology for Health Managers (4) Provides the vocabulary found in the health care arena, including terms related to anatomy, physiology, medical and laboratory reports as well as disease processes. Emphasis is placed on the concerns health care managers should have, based on this material.

BUHE 310 Orientation to Health Care Systems (4) A broad orientation to the health services industry. Segments of the health services industry are identified and described with historical background, functions, interrelationships, and future roles of each.

BUHE 311 Health Record Principles (4) Study of the health record, including definition, standards for content, and format. Also studied are the interactions of the health care professionals contributing to, utilizing, and analyzing health record data.

BUHE 312 Health Care Personnel Management (4) Principles of health care personnel recruitment, selection, and management. Characteristics of the professional health care worker are discussed. Legal responsibilities, collective bargaining, continuing education, and training are covered.

BUHE 314 Community Health Programs (4) Provides an understanding of the various agencies in place to promote and maintain health at the community, state, and national levels. *Preq. BUHE 310*

BUHE 385 Health Management Practicum (1-4) Field experience focuses on skill building in general management. Observation and experience in a variety of settings. Includes exploration of the relationship between departments and the critical need for communication within an organization. Also develops empathy for the various health care workers and support staff and their roles. *Preq. junior standing*

BUHE 410 Patient Care Issues in Long-Term Health Care Facilities (4) An overview of the total medical and social care required for residents of long-term health care facilities. Orientation to the various aspects required of the administrator and institution to provide for the total care of the individual. Topics include pharmaceutical services, disease process and recognition, biological aging, psychology of patient care, patient assessment, care planning, and nutrition.

BUHE 411 Administration in Extended Care Facilities (4) The role and responsibility of management as applied to a long-term health care facility. Includes discussion of ethical practices, licensure, state and federal agency requirements, and financial management.

BUHE 415 Administration in Acute Care Facilities (4) Focuses on issues important to the management, organization, planning, and evaluation of health care facilities and the services rendered to patients. Emphasis on the manager's role in a health care organization, caring for individuals in non-extended care circumstances. Identification of the various departments and services available and the interaction of each. *Preq. BUMG 310 and BUHE 310*

BUHE 416 Management Issues in Acute Care Facilities (4) Provides understanding of organizational behavior and management practices in non-extended health care facilities. Hands-on application of management skills and concepts. *Preq. BUHE 310 and BUMG 310*

BUHE 420 Problems in Health Care Management and Policies (4) A seminar course. Health care management problems are studied and recommendations offered for the resolution of those problems. It is recommended that this problems and policy course be taken as the last course in the health management concentration.

BUHE 430 Health Care Finance and Reimbursement (4) Analysis of reimbursement and payment systems for health care related organizations such as acute care, extended care, managed care, and other alternative care groups. *Preq. BUAC 101 and 102*

BUHE 451 Internship in Extended Health Care Management (6) Provides 400 hours of a structured and supervised professional experience within an approved extended health care organization. Students complete assigned projects and/or managerial tasks under joint supervision of a health care facility administrator and a university faculty member. *Preq. coursework completed and permission*

BUHE 452 Internship in Acute Health Care Management (6) Provides 400 hours of a structured and supervised professional experience within an approved acute health care related organization. Students complete assigned projects and/or managerial tasks under the joint supervision of a health care facility manager and a university faculty member. *Preq. coursework completed and permission; \$ B*

BUHE 499 Seminar - Health Management Topics (1-4) Discussion of current topics in the health care arena. *Preq. permission (May be repeated for a maximum of 6 hours); see special note on page 131.*

Business Information Systems

BUIS 099 Computer Fundamentals (2) Introduces basic computer literacy and skills to those who have only minimal knowledge and experience using computers. Topics include the processing cycle, comparisons of operating systems and applications programs, identification and use of the various functions within the Windows desktop, and introduction to the internet and Outlook. Students are also provided the opportunity to develop or refine acceptable keyboarding skills.

BUIS 103 Visual BASIC 1 (4) Students code and execute error free programs in the Visual BASIC language. This course serves as an introduction to computer programming concepts, problem solving, and programming logic. Students learn the design techniques of an object-oriented, event-driven language used to develop graphical user interfaces. *Preq. BUAI 101; \$ B*

BUIS 105 COBOL Programming 1 (4) Students code and execute error free programs in the COBOL language and learn the proper methods of top-down design and structured COBOL programming. *Preq. BUAI 101; \$ B*

BUIS 106 COBOL Programming 2 (4) A deeper study of COBOL. More complex problems, using tables and various utility programs. New instructions and different ways to utilize them are presented. *Preq. BUIS 105; \$ B*

BUIS 201 C Language (4) Introduction to C language programming in a highly interactive course. Students write programs that utilize the new topics presented, such as arrays, pointers, and files.

BUIS 203 - BULA 266

BUIS 203 Business Computer Projects (4) Research projects are assigned on both an individual and group basis. Students learn to function in a group setting as they conduct research related to the assigned topics. Theoretical systems concepts are explored in the classroom. A formal presentation is required. *Req. sophomore standing; \$ B*

BUIS 299 Special Topics in Business Information Systems (1-4) Opportunity for the student to work on special projects under the supervision of an instructor with expertise in the area of the student's project. *Req. instructor permission; see special note on page 131; \$ B*

Legal Assisting

BULA 101 Introduction to Legal Assisting (4) Practical introduction to the career of paralegalism. Describes the drafting, digesting, interviewing, investigating, and research skills required to be an effective paralegal or legal assistant. *\$ B*

BULA 212 Real Estate Law for Legal Assistants (4) Provides the essential substantive and practical skills necessary for a legal assistant to participate effectively in real estate transactions. Introduces real property concepts and examines the component parts of a real estate transaction, including entering into the purchase contract, providing a legally sufficient description of the property, preparing the deed, addressing the property's state of title, and conducting the closing. *Req. BULA 101; \$ B*

BULA 251 Legal Research and Writing 1 (4) Employs a step-by-step approach in introducing students to the legal system, interpreting court opinions and applying opinions in legal writing. Emphasis is on the study of court opinions through "key fact" identification and using these facts in the application process. *Req. BULA 101 and ENGL 111S; \$ B*

BULA 252 Legal Research and Writing 2 (4) A thorough overview of legal research and writing techniques. Covers information on citing cases, finding case law, and interpreting statutes. Instructs students in computer-assisted legal research, using LEXIS. *Req. BULA 251; \$ B*

BULA 261 Tort Law: Personal Injury Litigation (4) Presents an overview of tort law oriented to paralegals. Specific skill assignments in research analysis, drafting, investigation, and interviewing. Students can relate the law outlined in the book to the specific law of a particular state. *Req. BULA 101; \$ B*

BULA 262 Introduction to Civil Litigation (4) An introduction to the legal system of dispute resolution in noncriminal matters. Focuses on the process of civil litigation rather than on substantive legal issues. Explains the paralegal's role in interviewing clients, drafting pleadings and pretrial motions, conducting discovery, and preparing for trial. Contains examples of actual documents drafted by paralegals. *Req. BULA 101; \$ B*

BULA 263 Introduction to Contracts and Restitution (4) Introduces the laws of contracts and restitution with emphasis on applying the concepts presented to contract analysis and formation. Chapters present the rules of law, examples of how the rules apply to facts, and problems that help students apply the rules. Cases are examined to show how the courts apply the rules. *Req. BULA 101; \$ B*

BULA 264 Computer Application and the Law (4) Provides students and legal professionals with the minimum knowledge about computers that they will need to work efficiently in today's automated law practice. *\$ B*

BULA 265 Family Law (4) Comprehensive overview of family law for the nonlawyer. Practice-oriented text teaches students the skills and techniques in investigation and analysis and includes detailed coverage of child custody, contract cohabitation, property division, and support enforcement laws. *Req. BULA 101; \$ B*

BULA 266 Wills, Trusts, and Estate Administration (4) A paralegal course in probate or estate administration. Contains updated tax laws and tax forms affecting wills and estates. *Req. BULA 101; \$ B*

BULA 267 Legal Assisting Practicum (4) Students are placed in businesses where their acquired skills can be utilized and tested. This training is closely supervised by the instructor and consists of 160 hours of “hands-on” experience. *Preq. 24 credit hours of BULA, including BULA 252; 2.0 cumulative grade point average in all coursework and in BULA; and permission of instructor; \$ B*

BULA 269 Criminal Law/Criminal Procedure (4) Basic elements of criminal law and procedure dealing with the interpretation and recognition of the use of the criminal code. Assistance with all aspects of the pretrial through posttrial process. This includes investigations, motions, preparation, and research. Research assignments expand the student’s skills in this area. *Preq. BULA 101; \$ B*

BULA 270 Evidence (4) Introduces the importance of obtaining evidence through fact investigation and develops skills in discovering and organizing facts for use in litigation. *Preq. BULA 101; \$ B*

BULA 272 Ethics for the Legal Assistant (4) This course gives the student a look at the ABA Code and Rules of Professional Conduct, accepted nationally as the ethical expectations for legal professionals; the case law that has developed on the Codes and Rules; and standards aimed specifically at legal assistants. *Preq. BULA 101; \$ B*

BULA 273 Debtor/Creditor Law (4) An introduction to the general provisions of the Bankruptcy Code, administration of a bankruptcy case, liquidation, reorganization, preliminary considerations necessary prior to commencing a bankruptcy case, and various remedies afforded to the debtor and creditor. *Preq. BULA 101*

BULA 299 Special Topics in Legal Assisting (1-4) Individual or small-group study, under the supervision of an instructor, of topics not otherwise available to students. *Preq. BULA 101; see special note on page 131; \$ B*

Business Law

BULW 250 Business Law 1 (4) An introduction to the legal environment of business based on the uniform commercial code, including the forms and classifications of law, an overview of the court systems, court procedure, social forces and the law, torts and crimes, and the principles of contract law.

BULW 260 Business Law 2 (4) Includes the study of the law covering sales, agency and employment, commercial paper, personal property, and bailments. *Preq. BULW 250*

BULW 270 The Legal Environment of Business (4) An examination of the creation and evolution of principles and rules of law, emphasizing an understanding of the court system and court procedure, the role of administrative agencies and government regulations, and the study of criminal, tort, and the substantive law of contracts.

BULW 299 Special Topics in Legal Environment (1-4) Opportunity for the student to work on special projects under the supervision of an instructor with expertise in the area of the student’s project. *Preq. instructor permission; see special note on page 131*

Management

BUMG 101 Introduction to Business (4) A survey course of the basic functions of American business with an emphasis on the responsibility of business as a vital segment of society. Introduction to the American economic system and the role of profits as the motivating force behind U.S. business activity. (Not open to junior and senior business majors.)

BUMG 210 Management Concepts (4) An introductory course in management concepts, organization, and principles with a detailed analysis of the management functions of planning, organizing, staffing, directing, and controlling. Communications, decision making, and motivation are emphasized as integral concepts in performing the management functions. (Not open to those who have completed BUMG 310.)

BUMG 225 - BUMG 355

BUMG 225 Organization and Operation of Small Business (4) A course designed to provide the basics of small business: getting started, financial recordkeeping, cash flow management, computers, human resource management, marketing, pricing, advertising, and promotion.

BUMG 235 Personnel Management (4) The philosophy, principles, and methods of personnel management stressing human resource planning, recruiting, selection, placement, training, evaluation, wage and salary administration, and benefit programs. (Not open to those who have completed BUMG 335.)

BUMG 242 Business Communications (4) Principles and techniques of effective letter writing, letter mechanics, writing of personal business letters, including application letters, methods of writing business reports and letters, and internal and external reports as a means of communication. \$ B

BUMG 285 Enterprise Management and Strategy (4) An integrative course that enables students to demonstrate the capacity to synthesize and apply the knowledge and skills acquired from the various disciplines in business, social sciences, and humanities; to analyze case problems; and to develop and effectively communicate a comprehensive business project. *Preq.* 60 hours completed toward the associate degree, including BUAC 102, BUFI 245, BUMG 210, 242, and BUMK 210

BUMG 299 Special Topics in Small/General Business (1-4) Opportunity for the student to work on special projects under the supervision of an instructor with expertise in the area of the student's project. *Preq.* instructor permission; see special note on page 131.

BUMG 305 Professional Communication and Development Skills (4) A course designed to enhance students' awareness of the significant impact that communication skills and business etiquette have on their professional advancement. Emphasis is placed on the ability to write and present clear, concise, grammatically correct business correspondence and business reports for a diverse audience. Additional topics include: interviewing, networking, listening, and interpersonal skills. *Preq.* BUAI 102 and ENGL 115

BUMG 310 Management Principles (4) A study of the fundamental principles of management emphasizing the managerial functions, basic concepts of systems, decision making processes, organizational theory and behavior, and its effect on management. *Preq.* BUAC 102 or 201 and junior standing

BUMG 320 Data Analysis (4) Computer assisted statistical analysis using SPSS or current statistical application software as a research tool. In-depth use of computer applications for research, emphasizing statistical procedures, graphic design, and interpretation of results. Applications appropriate to business, social and physical sciences, psychology, and education. Special projects to suit student's needs. *Preq.* MATH 150 or BUMG 355 (*Suggestion: This course should be taken before BUMG 330.*); \$ B

BUMG 330 Organizational Communication (4) A study of the communication demands and skills relevant to the student's future role as a business or professional person. Organizational communication focuses on principles and techniques involved in organizing ideas, writing effective business letters and reports, and oral communication. Applications with computer assisted statistical analysis and graphic design used to enhance business reports. *Preq.* junior standing and BUMG 320 or MATH 150; \$ B

BUMG 335 Human Resource Management (4) Principles and practices of recruiting, selecting, training, developing, compensating, and maintaining a productive employee group through systematic human resource management planning consistent with government regulations. Includes attention to grievance and disciplinary procedures and collective bargaining. *Preq.* BUMG 310 or permission

BUMG 340 International Business (4) Introduces students to international business by exploring a broad spectrum of business activities. Competitive strategy provides the unifying theme.

BUMG 355 Quantitative Methods in Business (4) A study of the quantitative tools and techniques applied to business decision-making. The primary tool investigated is the linear regression model. Includes forecasting, multiple regression, qualitative variables, and the analysis of residual patterns. Also explores the linear programming model. Models are explained graphically, calculated manually, and then explored more fully on the computer. *Preq.* BUAI 101, MATH 150, and 170; \$ B

BUMG 385 Production/Operations Management (4) An overview of production and operations management, including procedures and techniques generally employed in both manufacturing and nonmanufacturing organizations. Topics include forecasting, line balancing, PERT, MRP inventory systems, layout planning, and capacity planning. Extensive use is made of computers. *Preq. BUMG 355; \$ B*

BUMG 410 Business Simulation (4) Explores the analysis of business problems using computer simulations. Outcomes resulting from various inputs are projected and interpreted to aid in decision making. *Preq. BUMG 355; \$ B*

BUMG 485 Business Policy and Strategy (4) A case-oriented course designed to develop skills in the integration of interdisciplinary areas as applied to problems in business. Includes both written and oral presentation of case problems. *Preq. BUFI 345, BUMG 310, 385, BUMK 310, and senior standing*

BUMG 499 Special Topics in Management (1-4) Opportunity for the junior or senior student to work on special projects under the supervision of an instructor with expertise in the area of the student's project. *Preq. instructor permission; see special note on page 131.*

Marketing

BUMK 210 Marketing Concepts (4) A study of marketing fundamentals, consumption, consumer behavior, retailing, wholesaling structures, the functions performed in marketing, marketing policies, and a critical appraisal of the field of marketing. (Not open to those who have completed BUMK 310.)

BUMK 220 Salesmanship (4) Basic concepts of personal selling at both the industrial and retail level, including preparation for selling, sales processes, and an introduction to sales management. Emphasis on retail selling, with a discussion of career opportunities. *Preq. BUMK 210 or 310*

BUMK 235 Advertising (4) A study of the principles of advertising, including the history and development of advertising, its relation to the marketing effort of the firm and to consumers and society in general, and the major groups of media used by the advertiser. *Preq. BUMK 210 or 310 or permission*

BUMK 239 Practical Business Applications (1-4) Student participates in an off-campus work experience with a business specializing in the student's area of interest. One credit hour is awarded for a minimum of seven scheduled clock hours of such activity per standard work week. *Preq. advisor permission*

BUMK 299 Special Topics in Retailing/Sales/Advertising (1-4) Opportunity for the student to work on special projects under the supervision of an instructor with expertise in the area of the student's project. *Preq. instructor permission; see special note on page 131.*

BUMK 310 Marketing Principles (4) A study of the marketing principles, concepts, strategies, and analytical methods used by organizations to market products, services, and ideas in dynamic environments. Emphasis on identifying marketing opportunities, defining target groups, developing appropriate products, promotion distribution, and pricing strategies.

BUMK 315 International Marketing (4) Directed at developing skills to make marketing decisions in a global context. This includes finding new markets, customizing products for the demands of new markets, determining needs, channels of distribution, pricing strategies, and segmentation. *Preq. BUMK 210 or 310 or international relations major*

BUMK 320 Sales Management (4) The principles and practices of planning, organizing, motivating, and controlling the sales force. Selection, training, compensation, analysis of sales potentials, and costs are also covered. *Preq. BUMK 210 or 310*

BUMK 325 Marketing Research (4) Techniques involved in the collection, tabulation, and analysis of marketing information. Includes statistical procedures and their marketing application, brand positioning, and market segmentation using marketing research techniques. *Preq. BUMK 310 and MATH 150; \$ B*

BUMK 400 - BUOA 242

BUMK 400 Marketing Management (4) A strategic focus on marketing management with a solid application of basic marketing concepts. Concentrates in the areas of decision making, competitor analysis, formulating a marketing plan, forecasting, and planning. *Preq. BUMK 310*

BUMK 499 Special Topics in Marketing (1-4) Opportunity for the junior or senior student to work on special projects under the supervision of an instructor with expertise in the area of the student's project. *Preq. BUMK 310 and instructor permission; see special note on page 131.*

Office Administration

BUOA 108 Beginning Document Processing (4) A study of the touch system of keyboarding at the microcomputer as well as an introduction to Word word processing software. \$ B

BUOA 111 Office Communications 1 (4) Introduction to machine transcription and the development of transcription skills, which include vocabulary development, spelling, punctuation, and grammar. A study of Outlook software *Preq. BUOA 222; \$ B*

BUOA 112 Office Communications 2 (4) Continuation of BUOA 111. Students are encouraged to master the use of transcription equipment and apply rules of punctuation and grammar to increasingly more difficult business documents. A study of PowerPoint software. *Preq. BUOA 111; \$ B*

BUOA 115 PowerPoint Fundamentals (2) An introduction to PowerPoint presentation software. *Preq. keyboarding skills and basic knowledge of microcomputers; \$ B*

BUOA 130 Records Management (4) Designed to emphasize the principles and practices of effective records management for manual, automated, and computer records systems. Access software is used to apply the ARMA alphabetic indexing rules. \$ B

BUOA 214 Microcomputer Office Practice (4) An integrated simulation using Office Word, Excel, PowerPoint, Access, and Outlook software. *Preq. BUOA 112, 215, and 217; \$ B*

BUOA 215 Spreadsheet Applications (4) A study of Excel software. *Preq. keyboarding skills and basic knowledge of microcomputers; \$ B*

BUOA 217 Office Computer Applications (4) A study of Access software. *Preq. keyboarding skills and basic knowledge of microcomputers; \$ B*

BUOA 218 Advanced Spreadsheet Applications (4) A continuation of BUOA 215 providing a study of the advanced applications of Excel software. *Preq. BUOA 215; \$ B*

BUOA 219 Advanced Office Computer Applications (4) A continuation of BUOA 217, providing a study of the advanced applications of Access software. *Preq. BUOA 217; \$ B*

BUOA 221 Word Processing 1 (4) Word processing concepts and skills are presented to the person with no previous training in word processing. Word software is used. *Preq. keyboarding skills and basic knowledge of microcomputers; \$ B*

BUOA 222 Word Processing 2 (4) Continuation of BUOA 221 with more advanced applications of Word software. *Preq. BUOA 221; \$ B*

BUOA 230 Desktop Publishing 1 (4) A study of Word desktop publishing software. *Preq. BUOA 222 or permission; \$ B*

BUOA 231 Desktop Publishing 2 (4) Continuation of BUOA 230. *Preq. BUOA 230; \$ B*

BUOA 241 Office Administration 1 (4) Introduction to the responsibilities and opportunities of an office administration position encompassing a variety of secretarial duties. Lab work is completed on a microcomputer. *Preq. BUOA 222; \$ B*

BUOA 242 Office Administration 2 (4) A continuation of BUOA 241, including assisting with travel arrangements, planning meetings, presenting business data, and handling financial procedures. *Preq. BUOA 241; \$ B*

BUOA 244 Medical Office Administration (4) The preparation of medical documents, emphasizing specialized terminology and proper procedures for preparing medical reports. *Preq.* BUOA 222; \$ B

BUOA 250 Office Administration Internship (1-4) Student participates in on-the-job work experience which allows the utilization of office administration skills. One credit hour is awarded for a minimum of seven scheduled clock hours of work per standard work week. *Preq.* *internship availability and approval; completion of at least 4 quarters of the office administration program with a "B" average in all BUOA classes; and advisor permission; \$ B*

BUOA 299 Special Topics in Office Administration (1-4) Opportunity for the student to work on special projects under the supervision of an instructor with expertise in the area of the student's project. *Preq.* *instructor permission; see special note on page 131; \$ B*

Real Estate

BURE 210 Real Estate Principles and Practices (4) Introduction to real estate economics and administration. Includes elementary physical, legal, locational, and economic characteristics of real estate; real estate markets; and national, regional, and local economic influences on real estate values. Serves as a preparation for securing a license.

BURE 212 Real Estate Law (4) Includes the law of agency as applied to real estate brokers and salesmen, law of fixtures, estates (including leases), conveyancing of real estate, real estate managers, license laws of Ohio, zoning, cooperatives, and condominiums.

BURE 216 Real Estate Appraisal and Finance (4) Introduction to legal, locational, and economic characteristics of real estate, including national, regional, and local influences on real property valuation. Financing—money, monetary systems, loans, foreclosures—is also explored. Serves as a preparation for securing a real estate license.

BURE 299 Special Topics in Real Estate (1-4) Opportunity for the student to work on special projects under the supervision of an instructor with expertise in the area of the student's project. *Preq.* *instructor permission; see special note on page 131.*

Chemistry

CHEM 101 Fundamental Chemistry (3) Designed for students with an inadequate background in chemistry or students who have not had high school chemistry prior to enrollment in CHEM 121 or 141. Topics and material presented are intended to increase student's familiarity with the periodic table, chemical processes, and chemical calculations. This course does not count towards the GEP requirement nor does it contain a laboratory. *Preq.* *high school algebra or MATH 101*

CHEM 121 Introduction to General Chemistry 1 (4) An introductory course in basic chemical concepts for nonscience majors. Topics include properties of matter, atomic structure, compound formation, chemical equations, inorganic nomenclature, gases, solutions, and acid-base chemistry. Credit allowed for only one of these introductory courses: CHEM 121 or 141. **GEP** *Preq.* *one year of high school chemistry or CHEM 101 or successful completion of MATH 130; 3 lec. 3 lab; \$ NS*

CHEM 122 Introduction to General Chemistry 2 (4) An introductory course in basic chemical concepts for nonscience majors. Topics include stoichiometry, chemical bonding, modern atomic theory, periodic table, chemical equilibrium, oxidation-reduction, and nuclear chemistry. Credit allowed for only one of these introductory courses: CHEM 122 or 142. *Preq.* *CHEM 121; 3 lec. 3 lab; \$ NS*

CHEM 141 General Chemistry 1 (5) An introduction to chemistry through the fundamental chemical concepts, inorganic nomenclature, periodic classification, mole concept, stoichiometry with problem solving, chemical reactions, atomic structure, bonding, and quantum theory. Credit allowed for only one of these introductory courses: CHEM 121 or 141. **GEP** *Preq.* *placement in MATH 130, a prior course in chemistry highly suggested; 4 lec. 3 lab; \$ NS*

CHEM 142 - CHEM 499

- CHEM 142 General Chemistry 2 (5)** An introduction to molecular structure, gas laws, states of matter and solutions, acid-base, kinetics, thermochemistry, and thermodynamics. *Preq. CHEM 122 or 141 and MATH 130 or above; 4 lec. 3 lab; \$ NS*
- CHEM 143 General Chemistry 3 (5)** An introduction to chemical equilibrium including acid-base and solubility, electrochemistry, nuclear and descriptive chemistry. *Preq. CHEM 142 and MATH 131 or above; 4 lec. 3 lab; \$ NS*
- CHEM 200 Introduction to Organic Chemistry (4)** A course in fundamental organic chemistry. The study of the major functional groups: saturated and unsaturated hydrocarbons, alcohols and ethers, aldehydes and ketones, carboxylic acids, amines, carboxylic acid derivatives. The organic chemistry of carbohydrates, lipids, and proteins. *Preq. CHEM 121 or 141; 3 lec. 3 lab; \$ NS*
- CHEM 299 Topics in Chemistry (1-4)** A study of topics not otherwise available to students.
- CHEM 305 Organic Chemistry 1 (4)** A course for science majors wishing to acquire a sound knowledge of classical and modern organic chemistry. Credit not allowed for both CHEM 200 and 305. *Preq./coreq. CHEM 143; 3 lec. 3 lab; \$ NS*
- CHEM 306 Organic Chemistry 2 (4)** Continuation of CHEM 305. *Preq. CHEM 305; 3 lec. 3 lab; \$ NS*
- CHEM 307 Organic Chemistry 3 (4)** Continuation of CHEM 305 and 306. *Preq. CHEM 306; 3 lec. 3 lab; \$ NS*
- CHEM 323 Analytical Chemistry 1 (5)** An introduction to methods of chemical analysis. Topics include statistics, equilibria, volumetric analysis, and an introduction to instrumental analysis. *Preq. CHEM 143 and MATH 132; 3 lec. 6 lab; \$ NS*
- CHEM 325 Analytical Chemistry 2 (5)** The use of electronic instrumentation (spectroscopic, chromatographic, and electrochemical) for chemical analyses. *Preq. CHEM 323; 3 lec. 6 lab; \$ NS*
- CHEM 431 Physical Chemistry 1 (4)** Zeroth, First, Second, and Third Laws of Thermodynamics. Standard thermodynamic functions of reactions. Reaction equilibrium in ideal gas mixtures. Real gases. One-component phase equilibrium. *Preq./coreq. CHEM 143, MATH 204, and PHYS 203 or 213; \$ NS*
- CHEM 432 Physical Chemistry 2 (4)** Extension of thermodynamics includes ideal and nonideal solutions, reaction equilibrium in nonideal systems, and multicomponent phase equilibrium. Second half of course covers kinetic theory and reaction kinetics. *Preq. CHEM 431; 3 lec. 3 lab; \$ NS*
- CHEM 433 Physical Chemistry 3 (4)** An introduction to quantum mechanics. Topics include the Schrodinger equation, particle-in-a-box problems, harmonic oscillator, rigid rotor, approximation methods, hydrogen-like atoms, the helium atom, the hydrogen molecule ion, MO and SCF methods. *Preq. CHEM 432; 3 lec. 3 lab; \$ NS*
- CHEM 441 Inorganic Chemistry (4)** A theoretical study of the dependence of periodic variations in elemental properties (atomic radius, first ionization enthalpy, electronegativity, and oxidation number) on quantum mechanical factors such as electron orbital shape. Topics include symmetry and group theory and a study of bonding using both VSEPR and MO approaches. *Preq./coreq. CHEM 143 and PHYS 203 or 213*
- CHEM 485 Senior Project (1-4; maximum 4)** In-depth study of a selected topic in chemistry, culminating in the preparation of a senior paper. *Preq. senior standing and instructor permission; \$ NS*
- CHEM 490 Seminar in Chemistry (1-4; maximum 4)** Study of a specific advanced topic in chemistry. *Preq. junior or senior standing and instructor permission*
- CHEM 495 Undergraduate Research (1-4; maximum 9)** Independent chemistry investigation under the direction of a faculty member. A written report is required. *Preq. senior standing, 2.75 grade point average in chemistry, and instructor permission; \$ NS*
- CHEM 499 Special Topics in Chemistry (1-4)** The study of topics not otherwise available to students. *\$ NS*

Dental Hygiene

DTHY 101 Radiology 1 (2) Didactic instruction in dental radiology. Topics include: characteristics of radiation, components and functions of the x-ray machine, and x-ray production. Emphasis on exposure factors and their effects on radiographs, effects of radiation biology, and radiation protection. Dental x-ray films and film processing are also covered. *\$ HS*

DTHY 102 General and Oral Histology and Embryology (2) Study of the development of tissues and structures from a histological and embryological basis. Emphasis on development of tissues of the teeth and the periodontal supporting structures. *Preq. BIOL 101; \$ HS*

DTHY 103 Nutrition (3) The principles of basic human nutrition with emphasis on nutritional diets and their relation to general and oral health. The study of valid nutritional information and healthful food selection. *\$ HS*

DTHY 111 Oral Anatomy 1 (3) A study of tooth form, function, and occlusion, including the supporting tissues of the teeth and oral environment. Emphasis on dental vocabulary, terminology, and the relationship of the permanent and primary dentition to clinical dental hygiene. *\$ HS*

DTHY 112 Oral Anatomy 2 (2) Detailed study of the anatomy of the head and neck. Topics include facial bones, muscles of the head and neck, nerve supply, and blood supply. Detailed study of the topographical and functional anatomy of the oral cavity and pharynx. *Preq. DTHY 111; \$ HS*

DTHY 113 Radiology 2 (2) Continuation of DTHY 101. Emphasis on radiographic technique through lecture and lab experiences. Lab experiences include bisection of the angle and paralleling techniques as well as extra-oral radiographs on training models. Students process and mount film, as well as learn to recognize processing and technical errors, normal anatomical landmarks, and pathology. *Preq. DTHY 101; \$ HS*

DTHY 121 Clinical Dental Hygiene 1 (4) Introduction to the profession and history of dental hygiene. The principles of preventive dentistry regarding etiology of deposits, caries, inflammation, and oral physiotherapy methods. Aseptic techniques are outlined. Basic instrumentation principles are demonstrated on typodonts followed by demonstration on partners. *\$ HS*

DTHY 122 Clinical Dental Hygiene 2 (4) Continuation of DTHY 121. Clinical skills include intra/extra oral examinations, dental/periodontal charting, scaling and polishing techniques, periodontal probing, and fluoride techniques. Skills are transferred from typodont to partner. *\$ HS*

DTHY 123 Clinical Dental Hygiene 3 (5) Continuation of DTHY 122. Techniques for dental hygiene care are performed in clinical patient treatment. Advanced skills include desensitization techniques, instrument sharpening, sequencing and planning patient treatment, and methods of motivating to prevent oral disease. *\$ HS*

DTHY 201 General and Oral Pathology (3) An introduction to pathology. Discussion of processes of inflammation, necrosis, retrograde changes, and wound healing. Etiologies, diagnosis, treatment, and prognosis of oral lesions. Pathology of diseases affecting teeth and their supporting structures. *Preq. BIOL 101 and 162; \$ HS*

DTHY 202 Periodontics (3) A study of the periodontal supporting structures of the teeth. Etiologies and classifications of periodontal disease are discussed. The treatment of periodontal disease is discussed in relation to the etiologies. *\$ HS*

DTHY 203 Dental Materials (3) Didactic and laboratory instruction on the physical properties of materials used in dentistry. Basic principles of the preparation and use of certain restorative materials, impression materials, and laboratory procedures, including chemical sealants, preliminary impressions, and study models. *\$ HS*

DTHY 204 Pharmacology and Anesthesiology (3) Drugs and anesthetics used and encountered in dentistry. Discussion of the origin, physical and chemical properties, effects on body systems, indications and contraindications for use, and methods of administration and elimination. *Preq. AHN 103 or CHEM 121; \$ HS*

DTHY 205 - ECON 302

DTHY 205 Dental Health Education (3) Analysis of goals for the development of dental health education programs. Major emphasis is on preparation and use of lesson plans and instructional materials for teaching groups. Involves classroom instruction of dental health in public schools. \$ HS

DTHY 206 Public Health (3) An introduction to the broad field of public health with emphasis on dental public health. A basic approach for designing and implementing a public dental health program to promote dental health and prevent dental diseases in the community. \$ HS

DTHY 220 Oral Microbiology/Immunology (3) A study of general microbiology as applied to oral disease and immunity. An in-depth study of ecology of the oral flora in health and disease. Applied microbiology principles are used in topics of sterilization and asepsis. *Preq. BIOL 101 and 162; \$ HS*

DTHY 224 Clinical Dental Hygiene 4 (5) Continuation of DTHY 123. Techniques and procedures of dental hygiene care and services performed in the clinic atmosphere as they would be in practice. Lecture topics concern medical emergencies in the dental office. \$ HS

DTHY 225 Clinical Dental Hygiene 5/Special Needs (5) Continuation of DTHY 224. Dental hygiene clinical practice includes applied nutrition as it relates to current concepts in preventive dentistry for the dental hygienist. \$ HS

DTHY 226 Clinical Dental Hygiene 6/Preventive Dentistry and Jurisprudence (5) Continuation of DTHY 225 with emphasis on prevention and trial state board patients. Ethics, jurisprudence, state laws, malpractice, and professional organizations are discussed as they relate to the dental hygiene profession. Career placement is investigated. \$ HS

DTHY 227 Clinical Dental Hygiene 7/Career Management (5) Continuation of DTHY 226. Complete dental hygiene care involving the use of advanced skills and techniques learned in previous dental hygiene courses. Special needs patients are discussed. Selected topics through seminars and lectures are presented to aid professional growth. \$ HS

DTHY 290 Seminar in Advanced Periodontics (1-3) Current concepts regarding nonsurgical treatment of periodontal disease. Major emphasis is placed on assessment of root planing techniques and maintenance and care of patients with periodontal disease. *Preq. DTHY 202 or permission of the program director; \$ HS*

DTHY 299 Topics in Dental Hygiene (1-5) A study of topics not otherwise available to students. \$ HS

Economics

ECON 103 Economics for the Social Sciences (4) Introduces students to the economy and to economics as a way of thinking about the world. Builds on and incorporates basic concepts from both micro and macroeconomics and examines the role of scarcity, choice, and institutions in framing the changing roles of the private and public sector in the U.S. economy over time.

ECON 201 Principles of Microeconomics (4) An elementary analysis of the principles of microeconomics. Includes a study of consumer behavior, different types of products and resource markets, and an analysis of certain economic problems. *Preq. MATH 101 and 105 or MATH 125*

ECON 202 Principles of Macroeconomics (4) An introduction to the elementary principles of macroeconomics. Includes a study of the economic system and an analysis of national income concepts, fiscal and monetary policies, and economic growth.

ECON 299 Topics in Economics (1-4) A study of topics not otherwise available to students.

ECON 301 Intermediate Microeconomics (4) A study of the economic theories of the consumer and the firm. Analysis of price and output behavior under various product and market structures and resource market analysis. *Preq. ECON 101 and 102*

ECON 302 Intermediate Macroeconomics (4) National income analysis; fiscal and monetary policies for economic stabilization. *Preq. ECON 101 and 102*

ECON 310 Money and Banking (4) Development of banking and the role of the Federal Reserve system in the U.S. Analysis of monetary policy for purpose of stabilization. *Preq. ECON 101 and 102*

ECON 320 History of Economic Thought (4) Evolution of economic thought and methods, with emphasis on the theories and ideas of the mercantilists, the physiocrats, the classicals, the neoclassicals, the Marxists, the Keynesians, and other schools of thought. *Preq. ECON 101 and 102*

ECON 326 Economic History of the U.S. (4) Analysis of the changes in the economic structure and development of the U.S. from colonial days to the present. Includes a survey of American economic life and the role of entrepreneurship in economic development. *Preq. ECON 101 and 102*

ECON 332 Managerial Economics (4) Use of economic theory and decision making techniques in business management. Production and consumer theory, applied price theory, pricing of final products, theory of profits, profit management, capital budgeting, cost and demand analysis theory to provide a solid foundation of economic understanding for use in managerial decision making. *Preq. ECON 101, 102, and MATH 201*

ECON 350 Labor Economics (4) Economic analysis of labor markets. Topics include labor supply and the derived demand for labor, human capital theory, labor market structures, trade unions, discrimination, and public policy toward labor. *Preq. ECON 101 and 102*

ECON 405 Economic Development (4) Analysis of economic problems and prospects for development in general and of less developed nations in particular. *Preq. ECON 101 and 102*

ECON 411 Comparative Economic Systems (4) An analysis of the different economic systems: capitalism, socialism, communism, and mixed systems. Survey of the differences and similarities of the economic institutions among these systems. *Preq. ECON 101 and 102*

ECON 425 Public Finance (4) Economic analysis of government finance theory and practice. Topics include the role of government in the allocation of resources and the distribution of income, the selection of alternate expenditure and tax schemes and their effects on the private sector, and public choice theory. *Preq. ECON 101 and 102*

ECON 450 International Trade (4) Theoretical framework of international trade; problems and policies for free trade; roles of international institutions. *Preq. ECON 101 and 102*

ECON 480 Econometrics (4) Economic analysis using linear regression techniques. Emphasis is on particular problems facing applied econometric researchers and practical solutions. Computer applications are included throughout the course. *Preq. ECON 101, 102, and MATH 250*

ECON 499 Special Topics in Economics (1-4) Individual or small-group study, under the supervision of instructor, of topics not otherwise available to students. Repeatable for credit. *Preq. ECON 101 and 102*

Adolescent Education

EDAE 285 Practicum and Seminar 1: Observation and Reflection in Professional Practice (4) Field based practicum with a weekly seminar to explore topics introduced in EDUC 115, 230, 240, and 245 and their relationship to the operation of schools. Emphasis includes skills of observation, techniques of reflection, and learning how to become a professional practitioner. Field placements are in local 7-12 classrooms and focus on education at that setting. *Preq. admission to teacher education and EDUC 115; preq./coreq. EDUC 230, 240, and 245; minimum 42 field experience hours, 10 lab; \$ Ed*

EDAE 385 Practicum and Seminar 2: Action Research - Home, School, and Community Relations (4) Field-based practicum with a weekly seminar to explore topics introduced in EDUC 310 and EDRE 305 and their relationship to the home, school, and community. Emphasis includes an introduction to action research with each student beginning an action research project with a self-chosen topic related to a specific educational issue. Students learn and practice specific research procedures, data collection techniques, and analysis skills in grades 7-12. *Preq./coreq. EDRE 305 and EDUC 310; minimum 63 field experience hours, 10 lab; \$ Ed*

EDAE 400 - EDEC 285

EDAE 400 Principles and Strategies of Curriculum Development, Management, and Instruction (4) Designed to give preservice teachers experience in theory and practice teaching students ages 12 through 21. Instructional strategies and design, classroom management, differentiated learning needs, and implementation are addressed in field and clinical practice. Students are exposed to peers specializing in different content areas and to extensive and continuous field work. *Preq. admission to licensure program and EDAE 385; coreq. EDAE 485 and the appropriate content methods course; 10 lab*

EDAE 485 Practicum and Seminar 3: Advance Action Research – Curriculum, Instruction, and Evaluation (4) Field based practicum with a weekly seminar to explore topics introduced in the appropriate methods courses. Students apply the skills and knowledge gained in university courses to the high school setting as they practice teaching methods, literacy strategies, evaluation and assessment techniques, and classroom management with a classroom teacher in an area high school. *Preq. admission to licensure program (level 2); coreq. EDAE 400 and the appropriate content methods course; minimum 126 field experience hours, 20 lab; \$ Ed*

EDAE 490 Directed Teaching and Seminar (12) A cumulative experience of at least ten weeks in area high schools. Includes a weekly seminar, both topical and process-oriented. *Preq. admission to student teaching; minimum 300 clinical experience hours, 20 lab; \$150.00 student teaching fee*

Early Childhood Education

EDEC 150 Introduction to Early Childhood Education (4) An integrated approach to identifying and responding within the essential roles of an early childhood educator serving children from birth through age eight in inclusive settings that respect cultural and linguistic diversity. Content focuses on issues within twelve key professional responsibilities. *10 lab*

EDEC 255 Educational Environments (4) Examines various components involved in developing programs that offer quality educational environments. The educational environment includes not only the physical space that children inhabit but also how the space interacts with the child. Methods of creating educational environments that are nurturing, stimulating, and welcoming for children—from birth through age eight—are explored. An overview of mental health issues and how the environment impacts brain development is presented. Activities that put theory to practice are emphasized. *Preq. EDUC 115; 10 lab*

EDEC 280 Administration of Early Childhood Programs (4) Introduces students to and prepares them for administrative and leadership roles in the field of early childhood education. An overview of various types of early childhood programs and philosophies is presented. Topics include family and community relations; planning, implementing, and evaluating programs; leading and managing personnel; financing and budgeting; record keeping; and establishing policies. *Preq. admission to teacher education and EDUC 115; 10 lab*

EDEC 283 Interprofessional and Parental Team Models (4) Explores the creative and reconceptualized delivery of services and the education of the whole child from birth through age eight. Methods of collaboration with parents, families, and intra- and interagency relationships are examined to include benefits, processes, and problem solving techniques and respect for cultural and linguistic diversity. The emphasis is on the importance of communication, teaming, and the assimilation of knowledge through interprofessional and parental relationships. *Preq. admission to teacher education; 10 lab*

EDEC 284 Basic Movement for Children (4) Provides students with an introduction to the basic components of motor development. Elements of the physical, psychomotor, cognitive, and affective domains are discussed. Developmentally appropriate practices in basic movement include the areas of muscular and cardiovascular endurance; flexibility; perceptual motor abilities; fundamental motor skills, including non-locomotor, locomotor, and manipulative skills; decision making; and social emotional development and are examined and applied in a lab setting. *Preq. admission to teacher education and EDUC 115; 10 lab*

EDEC 285 Practicum and Seminar 1: Observation and Reflection in Professional Practice (4) Field based practicum with a weekly seminar to explore topics introduced in EDUC 115, 230, 240, and 245 and their relationship to the operation of schools. Emphasis includes skills

of observation, techniques of reflection, and learning how to become a professional practitioner. Field placements are in local prek-3 settings. *Preq. admission to teacher education and EDUC 115; preq./coreq. EDUC 230, 240, and 245; minimum 42 field experience hours, 10 lab; \$ Ed*

EDEC 385 Practicum and Seminar 2: Action Research - Home, School, and Community Relations (4) Field-based practicum with a weekly seminar to explore topics introduced in EDUC 310 and EDRE 305 and their relationship to the home, school, and community. Emphasis includes an introduction to action research with each student beginning an action research project with a self-chosen topic related to a specific educational issue. Students learn and practice specific research procedures, data collection techniques, and analysis skills in prek-3 settings. *Preq./coreq. EDRE 302, 304, 305, and EDUC 310; minimum 63 field experience hours, 10 lab; \$ Ed*

EDEC 400 Teaching Creative Expressions for Early Childhood (Drama, Art, Music, Play, and Dance) (4) Introduction to play, art, drama, music, and dance as essential components to the educational development of the early learner. Developmental theories in the creative arts, movement, and play are examined. Emphasis is on designing and applying appropriate creative learning experiences for the early learner in accordance with Academic Content Standards and the NAEYC and CEC guidelines for the education of young children. *Preq. ARTP 201, MUSI 160, and admission to licensure program; coreq. EDEC 415 and 420; 10 lab*

EDEC 415 Teaching Developmental Mathematics and Science for Early Learners (4) This methods course is designed to help the early childhood teacher integrate teaching skills with the applied theory, practice, and knowledge from previous courses in early childhood. It is a content-based class, with reference to appropriate mathematics and science curriculum as indicated in Academic Content Standards for those areas and the NAEYC and CEC guidelines for the education of young children. Students design curriculum, instructional delivery, and student performance-based evaluation, integrating content and a range of developmental and learning style needs. Students demonstrate teaching design, develop, and “publish” lesson plans and units; and evaluate their own teaching effectiveness. *Preq. MATH 305; coreq. EDEC 400, 420, 485, and admission to licensure program; 10 lab*

EDEC 420 Teaching Developmental Language Arts and Social Studies for Early Learners (4) This methods course is designed to help the early childhood teacher integrate teaching skills with the applied theory, practice, and knowledge from previous courses in early childhood. It is a content-based class, with reference to appropriate language arts and social studies curriculum as indicated in the state of Ohio’s competency-based models for those content areas and the NAEYC and CEC guidelines for the education of young children. A primary focus of this course is on language acquisition and development of early learners. Students design curriculum, instructional delivery, and student performance-based evaluation, integrating content and a range of developmental and learning style needs. Students demonstrate teaching in a variety of clinical formats; design, develop, and “publish” lesson plans and units; and evaluate their own teaching effectiveness. *Coreq. EDEC 400, 415, 485, and admission to licensure program; 10 lab*

EDEC 425 Integrating the Early Childhood Curriculum (4) This course extends student exposure to curriculum development, the Academic Content Standards, and teaching strategies which integrate individual course topics, forming a seamless curriculum which encourages children’s physical, social, emotional, aesthetic, and cognitive development. Child development, the history of early childhood educational programs, and the value of cultural and linguistic diversity are addressed to help students understand the continuum of learning and the impact on child development. Professional issues pertaining to early childhood education are discussed throughout the course. *Preq. admission to licensure program; coreq. EDEC 485; 10 lab*

EDEC 485 Practicum and Seminar 3: Advance Action Research – Curriculum, Instruction, Evaluation (4) Field based practicum with a weekly seminar to explore topics introduced in the appropriate methods courses. The practicum component of this course provides students the opportunity to apply the skills and knowledge gained from university courses in pre-school through third grade settings. They implement teaching methods, literacy development strategies, evaluation and assessment techniques, and classroom management under the supervision of an experienced teacher in a PreK-3 classroom. Weekly seminars provide a supervised discussion of professional issues and elements of effective schools. Portfolio development is an element of the seminar. *Preq. admission to licensure program (level 2); coreq. EDEC 415 and 420; minimum 126 field experience hours, 20 lab*

EDEC 385 - EDEC 485

EDEC 490 - EDIS 385

EDEC 490 Directed Teaching and Seminar (12) A cumulative experience of at least ten weeks, working with children of different age groups and varying abilities. An experienced classroom teacher and university faculty supervise the student teaching experiences. A weekly seminar, both topical and process-oriented, focuses on professional issues related to early childhood and the profession of teaching. Portfolio development is an element of the seminar. *Preq. admission to licensure program and admission to student teaching; minimum 300 clinical experience hours, 20 lab; \$150.00*

Intervention Specialist Education

EDIS 250 Survey of Exceptionalities (4) Similarities and differences among the cognitive, physical, cultural, social, and emotional needs of individuals with and without exceptional needs. Understanding of pre-, peri-, and postnatal conditions that affect children's development and learning. Implications for curriculum development and the learning environment are addressed. *Preq. EDUC 115, 245, and admission to teacher education; minimum 10 lab hours*

EDIS 252 Movement, Health Issues, and Adaptive Technology (5) Health and medical conditions and their implications for learning and prevention. Generic medical terminology and developmentally appropriate practices and the effects of various factors (i.e., nutrition, genetics, neurology) on the educational, cognitive, psychomotor, perceptual, physical, social, and emotional behavior of individuals with exceptionalities. Examination of how technology can assist with planning and managing learning environments, as well as movement and alternative communication and learning systems for special needs students. *Preq. EDIS 250, EDUC 115, 245, and admission to teacher education; minimum 10 lab hours*

EDIS 283 Inter-Professional and Parental Team Models (4) Collaborative strategies in working with individuals with exceptional learning needs, parents, school and community personnel, and intra- and interagency relationships are examined to include benefits, processes, and problem solving techniques and respect for cultural and linguistic diversity, noting how this is addressed in various learning environments. The emphasis is on the importance of communication, teaming, monitoring, and periodic review of the prescribed individual program. *Preq. EDIS 250, EDUC 115, 245, and admission to teacher education; minimum 10 lab hours*

EDIS 285 Practicum and Seminar 1: Observation and Reflection in Professional Practice (4) Field based practicum with a weekly seminar to explore topics introduced in EDUC 115, 230, and 250 and their relationship to the operation of schools and the delivery of appropriate services to students with disabilities. Emphasis includes skills of observation, communication and collaboration, techniques of reflection, and learning how to become a professional practitioner. Field placements are in local schools with a variety of age levels and a special education program. *Preq./coreq. EDIS 250, EDUC 230, 240, 245, and admission to teacher education; minimum 42 field experience hours, 10 lab; \$ Ed*

EDIS 311 Fundamentals of Special Education: Assessment, Diagnosis, and Related Theories, Issues, and Legalities (5) Application and adaptation of assessment tools, methods, and procedures to accommodate the unique abilities/needs of students with disabilities (e.g., ecological inventories, portfolio assessments, social skills functional assessments, and future-based assessments). Apply pertinent theories, laws (eligibility, placement, procedural safeguards, etc.), issues (rights/responsibilities of parents, students, agencies), and historical information within this context. *Preq. EDIS 250, EDUC 115, 245, and admission to licensure program; preq./coreq. EDUC 310; minimum 15 lab hours*

EDIS 385 Practicum and Seminar 2: Action Research - Home, School, and Community Relations (4) Field-based practicum with a weekly seminar to explore topics introduced in EDUC 310 and EDRE 305 and their relationship to the home, school, and community. Emphasis includes an introduction to action research with each student beginning an action research project with a self-chosen topic related to a specific educational issue. Students learn and practice specific research procedures, data collection techniques, and analysis skills in intervention specialist settings. *Preq./coreq. EDIS 311, EDRE 302, 304, 305, and EDUC 310; minimum 63 field experience hours, 10 lab; \$ Ed*

EDIS 390 Behavior Management, Theorists, and Models (5) Various behavioral models, theories, and strategies, appropriate to the needs of individuals with exceptional learning needs in a variety of educational settings, are studied and applied. Personal management systems, inclusive of a congruent educational philosophy, are developed. *Preq. EDIS 250 and admission to licensure program; minimum 15 lab hours*

EDIS 423 The Intervention Specialist at the Early Childhood Level (4) Alternatives for teaching skills and strategies to individuals with disabilities, including instructional and remedial methods, techniques, and curriculum materials. Techniques for modifying instructional methods and materials and sources of specialized materials for students in grades P-3 with differing degrees and kinds of disabilities. *Preq. EDIS 390 and admission to licensure program; coreq. EDIS 485; EDIS 425 (for IS K-12 licensure only); minimum 20 lab hours*

EDIS 425 Instructional Strategies and Curriculum Design in a Continuum of Educational Environments for Middle Childhood and Adolescent/Young Adult Students (4) Instructional strategies and curricula for the development of motor, cognitive, academic, social, language, affective, career, and functional life skills for individuals with exceptional learning needs. The study of how different curricula and different instructional/behavioral strategies will be applied/modified to accommodate a continuum of education settings for grades 4-12. *Preq. admission to licensure program; coreq. EDIS 423 and 485; minimum 10 lab hours as well as field hours*

EDIS 485 Practicum and Seminar 3: Advance Action Research – Curriculum, Instruction, Evaluation (4) Field based practicum with a weekly seminar to holistically describe their field environment — IS role, materials, methods, degree of collaboration, paraprofessional supervision, etc. and ways to make each component more effective. Students apply the skills and knowledge gained in university courses to the school setting as they practice teaching methods, literacy strategies, evaluation and assessment techniques, and classroom management with special education teachers in area schools. *Preq. EDIS 385 (for MM K-12 license only), admission to licensure program; coreq. EDIS 423 and 425 (for IS K-12 license); EDEC 415, 420, and EDIS 423 (for IS PreK-3 license); minimum 126 field experience hours, 20 lab; \$ Ed*

EDIS 490 Directed Teaching & Seminar (12) A cumulative experience of ten weeks with children who have mild/moderate special needs in area schools. Course includes a weekly seminar, both topical and process-oriented. *Preq. EDIS 485, and admission to student teaching; minimum 300 clinical experience hours, 20 lab; student teaching fee \$150.00*

Middle Childhood Education

EDMC 285 Practicum and Seminar 1: Observation and Reflection in Professional Practice (4) Field based practicum with a weekly seminar to explore topics introduced in EDUC 115, 230, 240, and 245 and their relationship to the operation of schools. Emphasis includes skills of observation, techniques of reflection, and learning how to become a professional practitioner. Field placements are in local middle schools and focus on education at that setting. *Preq. admission to teacher education and EDUC 115; preq./coreq. EDUC 230, 240, and 245; minimum 42 field experience hours, 10 lab; \$ Ed*

EDMC 385 Practicum and Seminar 2: Action Research - Home, School, and Community Relations (4) Field-based practicum with a weekly seminar to explore topics introduced in EDUC 310 and EDRE 305 and their relationship to the home, school, and community. Emphasis includes an introduction to action research with each student beginning an action research project with a self-chosen topic related to a specific educational issue. Students learn and practice specific research procedures, data collection techniques, and analysis skills in middle schools. *Preq./coreq. EDRE 302, 304, 305, and EDUC 310; minimum 63 field experience hours, 10 lab; \$ Ed*

EDMC 470 Instructional Strategies and Management for Integrated Middle School Curriculum (4) Addresses instructional strategies and curriculum theory for middle childhood education. Academic Content Standards and Speciality Professional Association guidelines for all content areas are used to develop year-long curriculum plans. This course focuses on meeting the needs of learners in grades four through nine and also addresses the unique problems of parallel

EDMC 472 - EDPA 286

integration and scheduling in middle schools. This course is taken concurrently with content methods courses in two selected areas. *Preq. admission to licensure program; coreq. EDMC 485 and required content methods courses; 10 lab*

EDMC 472 Teaching Language Arts in the Middle Grades (4) Designed to give preservice teachers experiences in theory and practice for teaching language arts in grades 4-9. Instructional strategies and design, classroom management, differentiated learning needs, and implementation are addressed in field and clinical practice. *Preq. admission to licensure program; coreq. EDMC 470 and 485; 10 lab*

EDMC 473 Teaching Mathematics in the Middle Grades (4) Designed to acquaint the student with the practices and problems involved in teaching mathematics to the middle childhood age student (grades 4-9). Problem-solving, inquiry-based teaching and learning, cooperative learning, and the use of technology are emphasized. General teaching methods, patterns of instruction, and diagnostic techniques as they apply to the middle grades mathematics curriculum are discussed, observed, and practiced in both the school setting and clinical experience. *Preq. admission to licensure program; coreq. EDMC 470 and 485; 10 lab*

EDMC 475 Teaching Social Studies in the Middle Grades (4) Designed to give preservice teachers who are preparing to teach social studies in grades 4-9 experience in designing units of study, developing integrated thematic units, and acquiring learning strategies for classroom management, with special emphasis on methods and techniques of instruction in the social science disciplines. Curriculum development, materials review, and assessment techniques appropriate for the social sciences are addressed. *Preq. admission to licensure program; coreq. EDMC 470 and 485; 10 lab*

EDMC 476 Teaching Science in the Middle Grades (4) Designed to give preservice teachers experiences in theory and practice for teaching science in grades 4-9. Instructional strategies and design, classroom management, differentiated learning needs, and implementation are addressed in field and clinical practice. *Preq. admission to licensure program; coreq. EDMC 470 and 485; 10 lab*

EDMC 485 Practicum and Seminar 3: Advance Action Research – Curriculum, Instruction, Evaluation (4) Field based practicum with a weekly seminar to explore topics introduced in the appropriate content methods course. Students apply the skills and knowledge gained in university courses to the middle school setting as they practice teaching methods, literacy strategies, evaluation and assessment techniques, and classroom management with a classroom teacher in an area middle school. *Preq. admission to licensure program (level 2); coreq. EDMC 470 and the appropriate content methods course; minimum 126 field experience hours, 20 lab; \$Ed*

EDMC 490 Directed Teaching and Seminar (12) A cumulative experience of at least ten weeks in area middle schools. Includes a weekly seminar, both topical and process-oriented. *Preq. admission to student teaching; minimum 300 clinical experience hours, 20 lab; \$150.00 student teaching fee*

Prekindergarten Associate Degree

EDPA 285 Practicum and Seminar 1: Observation and Reflection in Professional Practice (4) Field based practicum with a weekly seminar to explore topics introduced in professional education courses and their relationship to the operation of early care and education programs. Emphasis includes skills of observation, techniques of reflection, and learning how to become a professional practitioner. The practicum component of this course provides students the opportunity to apply the skills and knowledge gained from university courses in settings serving children between the ages of birth through age five. Field placements are in local child care centers, prekindergartens, and elementary schools. Weekly seminars provide a supervised discussion of professional issues and elements of effective schools. Portfolio development is an element of the seminar. *Preq. admission to teacher education; preq./coreq. EDUC 230 and 245; field experience 42, 10 lab; \$ Ed*

EDPA 286 Aesthetics: Art, Music, Movement/Dance, Dramatic Play (3) Applies knowledge about how children develop and learn to provide opportunities that support their physical, social, emotional, language, and cognitive development, with an emphasis on young children's aesthetic development. Strategies and instructional techniques for presenting developmentally appropriate movement/dance, art, music, and dramatic play activities are presented. Issues of educational environment, curriculum development, assessment, technology, and classroom management are addressed.

The course addresses the need for understanding the nature of learning and human development in working with diverse learners and their families in children's aesthetic development. *Preq.* ARTP 201, EDEC/EDIS 284, EDPA/EDEC 285, MUSI 160, and admission to teacher education; coreq. EDPA 289; minimum 10 lab hours

EDPA 287 Symbolics: Language, Literacy, Reading, and Mathematics (3) Literature appealing to the young child is utilized to teach the symbolic concepts of language and mathematics. Developmentally appropriate practices and instructional methods to teach young children phonemic and phonological awareness are examined. Instructional techniques that proceed from the concrete to the abstract and apply to the young child's realm of meaning are presented. Curriculum development, assessment, technology, diversity, and classroom management are addressed. *Preq.* EDEC 255, 283, 284, EDUC 115, 245, MATH 110S, and NTSC 110S; coreq. EDPA 289; minimum 10 lab hours; \$ Ed

EDPA 288 Empirics: Health, Nutrition, Science, and Social Studies (3) Developmentally appropriate practices and instructional techniques in the content areas of science and social studies are examined. Issues of health and nutrition regarding the young child are examined. Strategies for establishing and maintaining physically and psychologically safe and healthy learning environments are studied. Curriculum development, assessment, technology, diversity, and classroom management are addressed. *Preq.* EDEC 255, 283, 284, and EDUC 245; coreq. EDPA 289; minimum 10 lab hours

EDPA 289 Instructional Methods Practicum (1-3) Provides students the opportunity to apply the skills and knowledge gained from the university courses in preschool settings. Emphasis include skills of observation, techniques of reflection, and learning how to become a professional practitioner. Students register for one hour of field for each methods course. *Coreq.* EDPA 286, EDPA 287, or EDPA 288; 10 lab

EDPA 290 Directed Teaching and Seminar (8) A two-part course: 1) a ten-week directed teaching experience in an early childhood educational setting, which includes diverse environments; and 2) a seminar for sharing the daily events in the lives of student teachers, collaborating with other student teachers and professionals in order to obtain multiple perspectives for more effective teaching and gaining additional substantive information regarding specified topics. *Preq./coreq.* EDEC 255, 283, 284, EDUC 115, 245, EDPA 286, EDPA 287, EDPA 288, and EDPA 289; 2 lec., minimum 300 clinical experience hours; \$ Ed

Reading Education

EDRE 302 Foundations of Literacy (5) Provides students with the knowledge and skills needed to assess progress in literacy development, design appropriate accommodations to maximize literacy and language acquisition for diverse students, and be knowledgeable of the many factors contributing to the evolution of early language acquisition and emergent reading and writing development. *Preq.* EDUC 240 and admission to teacher education program; 10 lab

EDRE 304 Teaching Phonics: Reading, Writing and Spelling (5) Emphasizes the need for continued attention to direct phonetic instruction at all grade levels. Vocabulary acquisition and enhancement, diction, inflection, pace, fluency, and comprehension strategies are stressed, as well as cultural diversity, literacy instruction, and phonemic awareness. Curriculum design, with an emphasis on integrating curriculum across content areas, is included. Students address and practice a variety of instructional deliveries, performance-based evaluation designs, and record keeping formats. Students incorporate their knowledge of cultural diversity, literacy instruction, and phonemic awareness within these designs/projects. Encoding/decoding assessment must be passed at a 90% level, as well as a manuscript/cursive writing assessment (when applicable to the certification/licensure area) prior to receiving a passing grade in the course. *Preq.* admission to licensure program or possession of a teaching certificate or license; 10 lab

EDRE 305 Teaching Reading in the Content Areas (4) Introduces techniques for integrating multiple avenues of reading and communication to access subject content. Strategies for reading are emphasized while students also explore writing, speaking, and expressive arts to support and enhance communication across the curriculum. Students design, deliver, and evaluate projects

EDRE 406 - EDUC 240

based on their certification/licensure area. Students incorporate their knowledge of cultural diversity, literacy instruction, and phonemic awareness within these designs/projects. *Preq. admission to licensure program or possession of a teaching certificate or license; minimum 15 lab hours*

EDRE 406 Reading Diagnosis and Assessment (5) Introduces techniques of assessing a student's reading ability, diagnosing reading difficulties, and evaluating progress toward literacy. Differences among readers and diversity of learners is stressed as university students design reading programs for individual students. Various instructional materials and strategies are introduced as students design, implement, and evaluate an individual reading plan, which evolves from a case study and report of a child. *Preq. EDRE 304 and admission to licensure program or possession of a teaching certificate or license; 12 field, 8 lab*

EDRE 407 Strategies in Reading Instruction (4) An extension of EDRE 406 which allows students to expand their instructional strategies for teaching reading, increase their skills at monitoring reading progress, and intervene when necessary. Students practice skills to create a classroom environment in their content area and school setting where reading is expected and rewarded. Field-based experience with an experienced and successful reading teacher at the appropriate age level is a required element. *Preq. EDRE 406 and admission to licensure program or possession of a teaching certificate or license; 12 field, 8 lab*

EDRE 485 Practicum and Seminar: Reading Instruction, Evaluation, and Intervention (3-6) Field based practicum with a weekly seminar to explore topics introduced in EDRE 304, 305, 406, and 407 and ENGL 300 or 312. The practicum component of this course provides students the opportunity to apply the skills and knowledge gained in the aforementioned courses in the setting to which it will be applied once endorsement is attained. The focus is the implementation of assessment methods, instructional strategies, and remedial/corrective strategies under the supervision of an experienced teacher with reading endorsement/licensure. Weekly seminars provide a supervised discussion of reading issues, collaboration activities, and the required Reading Portfolio. *Preq. EDRE 304, 305, 406, 407 (minimum grade of B in EDRE 304 and 406), and ENGL 300 or 312, admission to licensure program, and a successful review of a working Reading Portfolio; coreq. 50-126 clinical hours; \$ Ed*

Education

EDUC 101 Seminar in Education (1-4) Introduces new students to Shawnee State's teacher education and sports studies programs, assists with transition to college issues, and gives an in-depth look at careers and current issues in teaching and sports.

EDUC 115 Introduction to the Teaching Profession (4) An introduction to an explicit concept of teaching; to norms, conventions, expectations, and rewards for teachers. A general survey of professional ethics, knowledge about schools and school systems, and the history of American education. The cycle of plan/act/observe/reflect is developed both in class and in field experience settings. All students engage in classroom observations at the early, middle, and adolescent levels. The distinctive nature, scope, sequence, and demands of Shawnee State University's program are outlined. *18 field experience hours, 8 lab; \$ Ed*

EDUC 215 Orientation to Education (2) Supports students who are awarded transfer credit for EDUC 115. By completing this course, transfer students become familiar with program requirements and attain the necessary level of portfolio development for successful participation in the teacher education program.

EDUC 230 Instructional Media, Technology, and Computers (4) A study of skills needed for classroom teachers to effectively use media, technology, and computers as tools to enhance the instructional process and the learning environment for all learners. A focus on selection and operation of media, instructional aids, and computer software packages appropriate to particular instructional strategies and objectives. *Preq. EDUC 115; 40 lab; \$ Ed*

EDUC 240 School and Society: Legal, Theoretical, Philosophical, and Ethical Foundations of American Education (4) An examination of the relationship between school and society through the inquiry of a set of current issues in education. A variety of perspectives, including historical, philosophical, ethical, and legal, are taken in the inquiry. *Preq. admission to teacher education and EDUC 115; 10 lab*

EDUC 245 Teaching Individuals in a Pluralistic Society: Teaching Special Needs and Diverse Learners (4) Examination of the diverse microcultures that characterize today's student population. The course acquaints students with various approaches to multicultural education and underlying conceptual frameworks. Examines areas of exceptionality, the laws regarding exceptional learners, inclusion of exceptional learners in the regular classroom, adaptations in the classroom environment, instructional strategies, and evaluation procedures for exceptional learners. *Preq. admission to teacher education and EDUC 115; 10 lab*

EDUC 295 Independent Study (1-4) Exploration of special topics not included in the standard curriculum. *\$ Ed*

EDUC 310 Strategies for Assessment, Diagnosis, and Evaluation in the Classroom (4) An examination of a wide range of diagnostic, formative, summative, and confirmative evaluation techniques to be used as an integral part of the teaching/learning process. Authentic assessment of student learning is emphasized. This course maintains a focus on selection, development, and utilization of appropriate assessment and evaluation for individual learners. *Preq. admission to licensure program; 10 lab*

EDUC 495 Independent Study (2-4) Exploration of special topics not included in the standard curriculum.

Visual Arts Education

EDVA 285 Practicum and Seminar 1: Observation and Reflection in Professional Practice (4) Field based practicum with a weekly seminar to explore topics introduced in EDUC 115, 230, 240, and 245 and their relationship to the operation of schools. Emphasis includes skills of observation, techniques of reflection, and learning how to become a professional practitioner. Field placements are in local visual arts classrooms and focus on education at that setting. *Preq. admission to teacher education and EDUC 115; preq./coreq. EDUC 230, 240, and 245; minimum 42 field experience hours, 10 lab; \$ Ed*

EDVA 385 Practicum and Seminar 2: Action Research - Home, School, and Community Relations (4) Field-based practicum with a weekly seminar to explore topics introduced in EDUC 310 and EDRE 305 and their relationship to the home, school, and community. Emphasis includes an introduction to action research with each student beginning an action research project with a self-chosen topic related to a specific educational issue. Students learn and practice specific research procedures, data collection techniques, and analysis skills in visual art classes. *Preq./coreq. EDRE 305 and EDUC 310; minimum 63 field experience hours, 10 lab; \$ Ed*

EDVA 485 Practicum and Seminar 3: Advance Action Research – Curriculum, Instruction, Evaluation (4) Field based practicum with a weekly seminar to explore topics introduced in EDVA 401, 402, and 403, and the visual arts methods courses. Students apply the skills and knowledge gained in university courses to the school setting as they practice teaching methods, literacy strategies, evaluation and assessment techniques, and classroom management with classroom teachers in area high schools. *Preq. admission to licensure program (level 2); pre/coreq. ARTP 401, 402, and 403; minimum 126 field experience hours, 20 lab; \$ Ed*

EDVA 490 Directed Teaching and Seminar (12) A cumulative experience of at least ten weeks in area schools. Includes a weekly seminar, both topical and process-oriented. *Preq. admission to student teaching; minimum 300 clinical experience hours, 20 lab; \$150.00 student teaching fee*

Paramedic

EMTP 101 First Aid and CPR (2) Includes the American Red Cross Standard or National Safety Council first aid course related to bleeding control, obstructed airway management, splinting and bandaging techniques, and other emergency care procedures. Also includes the American Red Cross or American Heart Association adult CPR course. American Red Cross or National Safety Council first aid certification and Red Cross or American Heart Association adult CPR certification are granted upon successful completion of course. *\$ HS*

EMTP 102 - EMTP 232

EMTP 102 CPR (1) Techniques of cardiopulmonary resuscitation for adults, children, and infants. American Red Cross or American Heart Association CPR certification is granted upon successful completion of this course. *\$ HS*

EMTP 110 Emergency Victim Care (10) The Ohio Basic Emergency Medical Technician training course which provides the framework upon which all other skills and knowledge are developed. Principles of emergency care, CPR, vital signs, patient handling, endotracheal intubation, automatic defibrillation, and patient medication administration techniques are included. *Preq. advisor approval; \$ HS*

EMTP 120 EMS Systems (3) Introduction to pre-hospital emergency medical systems, including EMS history, types of systems, medical control, dispatch, quality assurance, communications systems, and record keeping. *Preq. advisor approval; \$ HS*

EMTP 130 Major Incident Response (2) Provides the student with the theoretical and practical foundations necessary to manage multiple casualty situations in the prehospital environment. *Preq. advisor approval; \$ HS*

EMTP 210 Paramedic Skills 1 (5) Expansion of basic skills and knowledge gained in the EMT-Basic course, in the areas of shock and fluid therapy, anatomy and physiology, patient assessment, pharmacology, and respiratory emergencies. Advanced skills include IV therapy, endotracheal intubation, parenteral drug administration, pneumatic anti-shock garment, automatic and manual defibrillation. Follows Ohio curriculum for EMT-Intermediate (September 2003). Includes 1998 US D.O.T. EMT-Paramedic National Standard Curriculum. *Preq. Ohio certified EMT-Basic and six months patient care experience; \$ HS*

EMTP 211 Paramedic Skills 1 Lab (1) Laboratory and clinical experience which correlate with EMTP 210 Paramedic Skills 1. *\$ HS*

EMTP 212 Paramedic Skills 1 Clinical (1) Hospital and field clinical experiences for EMTP 210. *\$ HS*

EMTP 215 Advanced EMT Defibrillation (4) Prehospital diagnosis and treatment of various forms of sudden cardiac death. Focuses on prehospital defibrillation. Includes cardiovascular anatomy and electrophysiology, cardiopulmonary resuscitation, assessment and management of cardiac arrest, including electrical defibrillation. Successful completion allows the Ohio certified Advanced EMT to perform defibrillation. *Preq. Ohio certified EMT-Basic and six months EMT-Basic experience; \$ HS*

EMTP 220 Paramedic Skills 2 (3) Emphasizes gaining access to, rescuing, and transporting a patient. Recognition and control of certain hazards, such as explosive material, downed electrical wires, toxic gases, and radiation. Use of radio equipment, protocols, and procedures for the transfer of information to the supervising physician. Follows Ohio Paramedic Curriculum 2000 and 1998 US D.O.T. EMT-Paramedic National Standard Curriculum as well as the American Heart Association Advanced Cardiac Life Support Provider course. *Preq. EMTP 210 or equivalent concurrently; \$ HS*

EMTP 230 Paramedic Skills 3 (8) Intensive emergency coronary care emphasis. Topics include pathophysiology, symptomatology, and emergency treatment of coronary artery disease, MI, angina pectoris, congestive heart failure, and other cardiac emergencies. Introduction to the general groups of drugs and the classification of each. Therapeutic effects, indications, contraindications, correct dosage, and side effects of specific drugs used in cardiac emergencies. Follows Ohio Paramedic Curriculum 2000 and 1998 US D.O.T. EMT-Paramedic National Standard Curriculum as well as the American Heart Association Advanced Cardiac Life Support Provider course. *Preq. EMTP 210, 211, 212, and 220 or equivalent; \$ HS*

EMTP 231 Paramedic Skills 3 Lab (1) Laboratory and clinical experiences which correlate with EMTP 230 Paramedic Skills 3. *\$ HS*

EMTP 232 Paramedic Skills 3 Clinical (1) Hospital and field clinical experiences for EMTP 230. *\$ HS*

EMTP 240 Paramedic Skills 4 (8) Builds advanced skills and knowledge in the areas of medical emergencies, trauma emergencies, obstetric/gynecologic emergencies, pediatrics, and neonatal transport. Emphasis placed on clinical and on-squad experience. Follows Ohio Paramedic Curriculum 2000 and 1998 US D.O.T. EMT-Paramedic National Standard Curriculum. *Preq. EMTP 230, 231, and 232 or equivalent; \$ HS*

EMTP 241 Paramedic Skills 4 Lab (1) Laboratory and clinical experiences which correlate with EMTP 240 Paramedic Skills 4. *\$ HS*

EMTP 242 Paramedic Skills 4 Clinical (1) Hospital and field clinical experiences for EMTP 240. *\$ HS*

EMTP 250 Advanced Emergency Procedures (3) Didactic and laboratory instruction in advanced emergency procedures, such as nasotracheal intubation, cricothyrotomy, intraosseous infusion, external cardiac pacing, and other procedures. *Preq. advisor approval; \$ HS*

EMTP 260 EMS Field Studies (3) Course relates field clinical experience of student to theory. Utilizes case review, discussion, and lecture for integration of theory with practice. *Preq. advisor approval; \$ HS*

EMTP 270 EMS Management (3) Course develops knowledge and skills relative to management of an emergency medical service. *Preq. advisor approval; \$ HS*

EMTP 295 Special Topics in EMS (1-4) Individual or small group study, under the supervision of an instructor, of topics not otherwise available to students. *\$ HS*

English

ENGL 095 Basic Writing 1: Mechanics (4) Provides intensive practice with the basics of written expression: grammar, punctuation, usage, spelling, and sentence structure. Emphasis on use of standard English. *Preq. placement*

ENGL 097 Reading Development 1 (4) Initial reading course in developmental education. Major focus is on comprehension and vocabulary improvement, adaptability of reading rate, and test-taking skills for standardized tests. Includes, but is not limited to, recognition of text structure, metacomprehension, strategies for building vocabulary, and test taking. Recreational and journal reading are required. *Preq. placement*

ENGL 098 Reading Development 2 (4) Second level reading course in developmental education. Major focus is on increasing comprehension and vocabulary growth; using three-stage reading plans, which include pre-reading, reading, and post-reading strategies; identifying and writing main ideas by summarizing textbook material; becoming metacomprehensive readers; and building general vocabulary. Reading fiction and nonfiction is required. *Preq. placement*

ENGL 099 Basic Writing 2: Paragraphs and Essays (4) Provides practice in the process of writing and revising paragraphs and short essays. Standard organizational patterns for paragraphs and essays are required with an emphasis on the use of standard English. *Preq. placement*

ENGL 105 Information Access (1) Prepares students to identify and find information using appropriate information technology, including the internet and World Wide Web, to evaluate resources and to format a bibliography.

SPECIAL NOTE: *The university placement test is prerequisite to enrolling in ENGL 111S. Students completing developmental courses are required to pass not only the course itself but also the course exit exam before enrolling in ENGL 111S. Those students who enter Shawnee State University with an English subject ACT score of 22 or higher or the SAT equivalent will be permitted to register for ENGL 111S without taking any English placement test. ENGL 111S, 112S, and 115S must be taken in sequence, beginning with 111S. This composition sequence is a prerequisite for advanced coursework in English (including the civilization and literature series).*

ENGL 111S - ENGL 252

ENGL 111S Discourse and Composition¹ (4) An introduction to discourse in both public and academic settings. *GED* *Preq. placement or the appropriate developmental course(s), which may include ENGL 095, 097, 098, 099, and 105; \$ H*

ENGL 112S Composition and Research1 (4) An introduction to the relationship between research and composition. *GED* *Preq. ENGL 111S; \$ H*

ENGL 115S Composition and Literature (4) An introduction to the relationship between literature and composition. *GED* *Preq. ENGL 112S; \$ H*

ENGL 120 Vocabulary Expansion (2) A non-developmental course intended primarily to enhance the vocabulary skills of students with a reasonable range of existing vocabulary. *\$ H*

ENGL 121 Technical Writing 1 (4) A course which stresses skills needed to produce professional-quality documents that effectively convey technical information. The fundamentals of audience analysis, document design and organization, revision, and achieving a readable style are addressed. Students produce basic workplace documents, such as technical definitions, product descriptions, instructions, and brief reports. Taught in the computer lab. *\$ H*

ENGL 200 Introduction to Literature (4) An analysis of selected literary works which aims to develop reading and interpretive skills and to familiarize students with the language of literary study. *We encourage English majors to make English 200 one of the first literature courses in which they enroll. Ideally, it should be the first course students take in the major.*

ENGL 205 Introduction to Women's Studies (4) An interdisciplinary and cross-cultural examination of the images, power relationships, and cultural and historical sources through which femininity has been constituted within cultures.

ENGL 211 Survey of English Literature 1 (4) Survey of the development of English literary traditions from the Medieval Period through the eighteenth century.

ENGL 212 Survey of English Literature 2 (4) Survey of the development of English literature beginning with the Romantics and moving into contemporary writers and works.

ENGL 221 English in the Workplace (4) Intensive examination of effective writing style. Emphasizes clarity and conciseness in sentence structures, transitional devices and organizational patterns at the paragraph level, formatting as a means of improving the readability of texts, precision in word choice, and developing a personal and persuasive style. *Preq./coreq. ENGL 111S and 112S; \$ H*

ENGL 222 Business Writing (4) A study of writing skills essential to the business world with special emphasis on the practical application of those skills to "real world" writing tasks.

ENGL 232 Creative Writing (Poetry) (4) An advanced poetry writing course. Students study modern poetry at the same time they are writing their own. They also offer criticism of work done by others in the class.

ENGL 240 Screenwriting (4) An introduction to the elements of screenwriting. Students may develop an original screenplay or write a screen adaptation of a published work as well as study important distinctions between visual and literary art forms.

ENGL 245 Creative Writing (Fiction) (4) An introduction to the elements of fiction writing. Students critique their own manuscripts as well as study selected works of published writers.

ENGL 249 Native American Literature (4) Study of works written by Native American writers.

ENGL 251 Survey of American Literature 1 (4) Study of major works and major authors from the Colonial Period through American Romanticism.

ENGL 252 Survey of American Literature 2 (4) Study of major works and major authors from the Age of Realism to the twentieth century.

¹ In keeping with the general education program's commitment to computer literacy (see Catalog p. 56), several sections of this course use computers in the teaching of composition.

ENGL 273 Modern American Poetry (4) Study of themes and forms prevalent in modern American poetry.

ENGL 275 American Film History (4) Chronological study of the influence of American history upon American film, and vice versa. Students become acquainted with the work and themes of some of America's significant film directors and major genres of American popular film. **GEP**

ENGL 280 Introduction to American Studies 1 (4) Interdisciplinary study of American culture.

ENGL 281 Introduction to American Studies 2 (4) Interdisciplinary study of American culture.

ENGL 299 Topics in English (1-4) Study of selected topics not otherwise available.

ENGL 300 Children's Literature (4) A survey of children's literature primarily designed for future teachers of young children. Topics include the analysis and evaluation of literature, genres, and creative teaching strategies.

ENGL 301 Shakespeare 1 (4) Intensive study of the tragedies and histories.

ENGL 302 Shakespeare 2 (4) Intensive study of the comedies and problem plays.

ENGL 305 Creative Nonfiction (4) Explores ways of writing for different audiences. Provides opportunities to write about real world topics, employing styles drawn from "new journalism," memoir writing, literary journalism, creative writing in the sciences, nature and travel, trends in biography and profiles, and narrative nonfiction. Attention is paid to stylistic development and individual voice. *Preq. ENGL 111S, 112S, and 115S; \$ H*

ENGL 306 Professional Writing (4) A continuation of ENGL121. This course stresses the techniques of research, organization, and writing that produce professional material for the contemporary workplace. Topics of design and production of internal and external management communications (e.g., newsletters, brochures, fact sheets, annual reports, and information/media kits) are included. Taught in the computer lab. *Preq. ENGL 111S, 112S, and 115S; \$ H*

ENGL 311 Major English Authors (Before 1800) (4) A variable content course which focuses on major authors for the purpose of carefully analyzing their works and detailing their development as writers.

ENGL 312 Major English Authors (After 1800) (4) A variable content course which focuses on major authors for the purpose of carefully analyzing their works and detailing their development as writers.

ENGL 315 Theory and Practice in Composition (4) Study of varied methods and strategies for teaching composition with special attention to classroom application for teachers. *\$ H*

ENGL 321 The English Novel (4) A variable content course which examines the emergence and development of the English novel.

ENGL 322 Modern English Drama (4) Study of the developments in English theatre in the 20th century.

ENGL 323 Adolescent Literature (4) A survey and methods course designed to give secondary and middle-school level preservice teachers experience in the range, quality, genres, and styles of literature suitable for use in classrooms.

ENGL 332 Poetry Workshop (4) An advanced poetry writing course with a major emphasis placed on critiquing the writing of the students in the class for the sake of successfully marketing their work.

ENGL 335 Interpersonal Communication (4) Combines theory and practice to develop an understanding of effective use of dyadic and small group communication. Methods of problem-solving and decision-making are explored, and effective group member and leader roles and responsibilities are studied and practiced. Students learn how and when to make use of unique or specialized group approaches and how to plan and conduct effective meetings. Strategies for planning and structuring several types of interviews are studied and practiced from the perspective of both the interviewer and interviewee. *Preq. ENGL 111S, 112S, and 115S; SPCH 103*

ENGL 340 - ENGL 424

ENGL 340 Literature of the Americas (4) A study of the literature of Hispanic America with emphasis on the most celebrated contemporary writers. *Preq. ENGL 111S, 112S, and 115S*

ENGL 341 Literature of Initiation and Experience (4) Study of literary works which detail growth and development of character.

ENGL 342 Women in Literature (4) Study of works by and about women.

ENGL 343 Black Authors (4) Study of works about the Black experience.

ENGL 344 Literature of Appalachia (4) Exploration of southern Appalachian experience in literature. Includes works by authors past and present who are themselves products of the region or who have focused on the region in their prose or poetry.

ENGL 346 River Literature (4) Study of literary works in which rivers are central factors influencing experience.

ENGL 351 Major American Authors (4) Intensive study of one or two major authors to provide a detailed understanding of works, thought, and literary development.

ENGL 360 Introduction to Language and Linguistics (4) A discussion and analysis of the fundamental properties and processes of the world's languages. A review of the major systems and features which constitute language. A discussion of language change, typology, and aspects of language acquisition.

ENGL 362 Patterns of English (4) An examination of various English phonological and spelling patterns, followed by questions of variation and usage. Aspects of English phrase, clause, and sentence structure are also examined. *Preq. ENGL 360*

ENGL 365 History of English (4) A survey of the patterns and events which have shaped the English language from the time of the Anglo-Saxon to the present. *Preq. ENGL 360 or EDUC 115; This course does not fulfill any history course requirements of the history major.*

ENGL 371 The American Novel (4) A variable content course which examines the emergence and development of the American novel.

ENGL 381 Fundamentals of Criticism (4) Study of both ancient and modern theories of criticism.

ENGL 385 Cultural Studies: Theories and Methods (4) Introduction to influential primary sources—theorists and practitioners—who have helped to define the new field of cultural studies, and redefined the more traditional fields of literary study since the middle of the twentieth century. Issues stressed include production and consumption of cultural texts and the social impact of cultural power and its role in the formation of identities. Among foundational theories and practices addressed in the course are the following: Marxism and Marxist Criticism, communications and mass media, structuralism, poststructuralism, postmodernism, psychoanalysis, history, postcolonialism, and theories of race, class, and gender and sexuality. *Preq. ENGL 111S, 112S, 115S, and 200*

ENGL 392 Intercultural Communication (4) Overview of the major principles, theories, and systems of intercultural communication with specific focus on technological and media contexts. *Preq. ENGL 111S, 112S, 115S, and SPCH 103*

ENGL 399 Topics in Literature (1-4) Study of topics not otherwise available.

ENGL 411 16th Century Renaissance Literature (4) Study of the major works of selected authors such as More, Sidney, Spenser, Marlowe, Shakespeare, Shelton, Wyatt, Surrey, and others.

ENGL 421 17th Century Literature (4) Study of the major works of selected authors such as Bacon, Carew, Cowley, Donne, Herrick, Jonson, Marvell, Webster, and Milton.

ENGL 424 The 18th Century Novel (4) A consideration of major works and authors of the period.

ENGL 434 Methods of Teaching Language Arts in the Secondary Schools (4)

Provides preservice teachers with essential experiences in theory and practice for teaching language arts students, ages 12 through 21. Instructional strategies and design, classroom management, differentiated learning needs, and implementation are addressed in field and clinical practice. *Preq. senior class standing and admission to the licensure program; coreq. EDAE 400 and 485; \$ H*

ENGL 441 The Romantics (4) Study of the poetry and prose of major Romantic writers, including Blake, Wordsworth, Coleridge, Shelly, Byron, and Keats.

ENGL 446 The Victorians (4) Study of English poetry and prose from 1830 to 1900.

ENGL 452 Language Acquisition (4) A systematic study of how human language develops. The course examines what the main factors are that influence language development. Acquisition of dialect vs. standard structure and the transition from a home dialect to a school dialect are central to the course. *Preq. ENGL 360*

ENGL 455 English Language in Society (4) Language variation by individual speakers is analyzed in relation to the reasons and extent of variation, paying particular attention to English. Then the processes and characteristics associated with different contact and social varieties of English are detailed. Finally, English geographic variation and patterning is reviewed. *Preq. ENGL 360*

ENGL 460 Topics in Linguistics (4) Senior seminar in selected topics in linguistics: linguistics and literature, social aspects of language, psychological aspects of language, varieties of English, English as a second language, and Black English (including Pidgin and Creole). Can be taken more than once when different themes are offered. *Preq. ENGL 360*

ENGL 461 19th Century American Literature (4) Intensive study of major authors and works of the 19th century.

ENGL 471 20th Century American Literature (4) Intensive study of major authors and works of the 20th century.

ENGL 480 Popular Culture and the Mass Media (4) A study of the theories, functions, and production of popular arts, artifacts, and entertainments, with particular emphasis upon critical evaluation of literature, movies, TV, and popular music. *Preq. ENGL 111S, 112S, and 115S; students are encouraged to take JOUR 105 before enrolling in this class.*

ENGL 485 Senior Experience for English/Humanities Majors (4) Students examine in detail a selected topic of the instructor's specialty. A major research essay and oral presentation are required. Part of the course involves a portfolio review of previous writings in other courses. *Preq. completion of 60 quarter hours in the major*

ENGL 490 Management Communication (4) A study of the flow of internal and external communication within organizations. The on-going communication process is viewed in its environmental context and in light of the goals of individuals and the organization itself. A combination of theoretical and practical approaches to the study of formal and informal interactions, channels, and verbal and non-verbal messages are used. *Preq. ENGL 111S, 112S, 115S, and SPCH 103; students are encouraged to take ENGL 335 before enrolling in this class.*

ENGL 495 Independent Study (4) Independent investigation of literary topics under the direction of a faculty member.

ENGL 499 Topics in Literature (1-4) A seminar course in selected topics in literature. Specific topic chosen by the instructor.

English as a Second Language

ESL 91 Elementary English 1 (5) Development of elementary listening, comprehension, speaking, reading, and writing skills in English. Laboratory exercises are used to reinforce these skills.

ESL 92 Elementary English 2 (5) Continuation of ESL 91. *Preq. ESL 91*

ESL 93 Elementary English 3 (5) Continuation of ESL 92. *Preq. ESL 92*

ESL 94 - ETCA 150

ESL 94 Intermediate English 1 (5) Development of intermediate oral communication skills in English, but with increased emphasis in reading and writing. May be taken concurrently with ESL 93. *Preq. ESL 93 or satisfactory score on ESL assessment test*

ESL 95 Intermediate English 2 (5) Continuation of ESL 94. *Preq. ESL 94 or satisfactory score on ESL assessment test*

ESL 96 Intermediate English 3 (5) Development of advanced communicative skills in English. May be taken concurrently with ESL 97, 98, and 99. *Preq. ESL 95 or satisfactory score on ESL assessment test*

ESL 97 Advanced English 1 (5) A follow-up to ESL 96. A course emphasizing oral proficiency and applied grammatical concepts. Improvement of speed and comprehension in reading through conscious analysis of paragraph structure and recognizing the progressive development of ideas. May be taken concurrently with ESL 96, 98, and 99. *Preq. ESL 96 or satisfactory score on ESL assessment test*

ESL 98 Advanced English 2 (5) Training in the fundamental skills, including grammar, usage, organization, and development. For international students, includes idiomatic expressions and problems common to non-native speakers of English. Utilizes methodologies appropriate for international students. Designed to prepare international students for Discourse and Composition. *Preq. ESL 96 or satisfactory score on ESL assessment test*

ESL 101 English for International Students (Equivalent to ENGL 111S) (4) Review of sentence structure, mechanics and usage, paragraph development, and short essay organization. For international students, includes reading and analysis of prose models and work on other English fundamentals. Emphasis on revising for clarity, coherence, and organization. Utilizes methods appropriate for ESL students.

Computer Aided Drafting and Design

ETCA 101 Introduction to CADD (3) Hands on experience using industrial standard hardware and software for computer aided drafting. Students learn to set up, edit, and output drawings using the latest in CADD technology. Introduction to file management techniques and the disk operating system (DOS). All classes focus on the use of AutoCAD® unless otherwise stated. *Coreq. ETEG 110 or CADD faculty approval; 2 lec. 3 lab; \$ ET*

ETCA 102 Mechanical Drafting with CADD (3) Students further develop and refine skills in operating a CADD workstation. Additional commands and more advanced techniques are introduced involving typical 2-D mechanical drafting and design techniques. *Preq. ETCA 101 or advisor approval; 2 lec. 3 lab; \$ ET*

ETCA 103 CADD Menu Customization (3) Students develop symbol libraries and icons to be used with student developed tablet and screen menus. *Preq. ETCA 101 or CADD faculty approval; 2 lec. 3 lab; \$ ET*

ETCA 104 Advanced Drafting with CADD (3) Advanced drafting and CADD concepts to include surface design and development and advanced descriptive geometry techniques. *Preq. ETCA 102 or CADD faculty approval; 2 lec. 3 lab; \$ ET*

ETCA 105 3-D Modeling with CADD (3) Wireframe modeling, surface modeling, and solid modeling are taught with an emphasis on mechanical parts design. Students gain an appreciation for the capabilities and limitations of each modeling technique. *Preq. ETCA 101 or CADD faculty approval; 2 lec. 3 lab; \$ ET*

ETCA 150 Computer Aided Machining (3) Introduction to computer aided machining (CAM) and computer numerical control (CNC). Intended for students having no prior CAM or CNC experience. The course focuses on the creation and editing of tool path geometry, display control, file manipulation, verification of data, and output of CNC code. Laboratory experiences include CAM, CNC programming, and CNC machine tool operations. *Preq. ETCA 101 or CADD faculty approval; \$ ET*

ETCA 201 Small Building Design with CADD (3) Introduction to architectural drafting through the design of a residential structure. Students create the drawings necessary to complete a typical set of house plans. Topics include, but are not limited to, design techniques, floor plans, foundation plans, elevations, wall sections, window and door schedules. *Preq. ETCA 103; 2 lec. 3 lab; \$ ET*

ETCA 202 Piping Drawings with CADD (3) Representation of piping in single and double line diagrams, isometric and orthographic diagrams. Design of pipe flanges given the size of pipe and the operating pressure. Template layouts for cutting pipe to form turns of various angles. *Preq. ETCA 103; 2 lec. 3 lab; \$ ET*

ETCA 203 Welded Parts Design with CADD (3) Welding processes and procedures are covered to the extent necessary to make production weldment drawings. Delineating weld symbols is emphasized. *Preq. ETCA 103; 2 lec. 3 lab; \$ ET*

ETCA 204 Casting and Mold Design with CADD (3) Completion of a set of plans giving the specifications a foundry would need to manufacture a part. The plans include: a pattern drawing with gates, a core box drawing, the casting drawing of the part, and machined part drawing. *Preq. ETCA 103; 2 lec. 3 lab; \$ ET*

ETCA 205 LISP Programming (3) A wide range of design problems are solved using LISP programming, subsequent to a thorough study of LISP functions, variable naming conventions, entity access, and device access. A variety of existing LISP routines and student written routines are analyzed. *Preq. ETCA 103 or CADD faculty approval; 2 lec. 3 lab; \$ ET*

ETCA 220 MicroStation (3) An introductory course on the methods and techniques of MicroStation (a high-end CAD package). Students develop skills in both 2-D drafting and 3-D design. *Preq. ETCA 101 or CADD faculty approval; \$ ET*

ETCA 230 Rendering and Animation (3) Advanced techniques in rendering and animating 3-D CAD models for presentation graphics. Animated “fly-bys” and “walk-throughs” allow the operator to view the CAD model as though walking through it or flying past it. Rendering techniques include the use of AutoDesk’s 3-D Studio. *Preq. ETCA 105 or CADD faculty approval; \$ ET*

ETCA 250 Solid Modeling (3) In-depth instruction in solid modeling using constructive solid geometry and Boolean operations. Students create solid models and calculate mass properties to solve mechanical design problems. *Preq. ETCA 105; \$ ET*

ETCA 299 Special Topics in CADD (1-5) Offered as an elective for CADD students. Covers topics of special interest. *Preq. instructor permission*

Engineering Technology Core

ETCO 110 Computer Applications for Engineering Technology (2) Utilization of computer concepts, including operating systems, navigation, commands and applications software for file management, presentation graphics, and internet navigation. *\$ ET*

ETCO 115 VBASIC Computer Programming (4) Introduction to computer hardware, a high level programming language, an integrated development environment, control structures, procedures and functions, and graphical user interface (GUI) concepts to develop computer programs for various applications. Focus is on problem solving and algorithm development and analysis. *\$ ET*

ETCO 116 JAVA Computer Programming (4) Introduction to computer hardware, a high level programming language, objects, methods, control structures, and graphical user interface (GUI) concept to develop computer programs for various applications. Course focus is on problem solving and algorithm development and analysis. *\$ ET*

ETCO 117 Software Tools for Technology (4) Utilization of computer hardware and a high level programming application (Mathcad®) to create worksheets, functions, 2D and 3D plots, graphics and interactive operations to develop computer programs for technology applications. ETCO 110 recommended corequisite for students unfamiliar with Windows environment. *Preq. MATH 131; 4 lec. 4 lab; \$ ET*

ETCO 150 - ETEC 200

ETCO 150 HTML Programming/Web Page Design (4) Utilization of computer hardware and a high level programming application (HTML) to design and construct interactive web pages. Topics include Internet browsers, HTML programming language, graphics and file management, shareware, guestbooks and forms, and JAVA™ applets. ETCO 110 recommended corequisite for students unfamiliar with Windows environment. \$ ET

ETCO 202 Statics and Strength of Materials (4) A study of the principles of torque and displacement in a wide variety of gearing applications along with the analysis of forces or loads acting upon the system. Analysis of stress and strain, strength of materials, friction, torsion, and moment of inertia. *Preq. MATH 132 or faculty approval; 3 lec. 3 lab; \$ ET*

ETCO 210 Occupational Safety and Health Management (3) Industrial safety, occupational health issues, accident prevention, working conditions, provisions and policies of OSHA. Compliance with OSHA regulations. Course includes OSHA 10-Hour General Industry Voluntary Compliance Card. *Preq. sophomore standing and GPA of 2.0 or faculty approval*

ETCO 220 Hydraulics and Pneumatics (3) A study of the functions of various hydraulic and pneumatic components and methods of combining them to build complex systems. Emphasis on understanding the physical properties of fluids and gases and their use for power transmission and for control. *Preq. MATH 130 or faculty approval; 2 lec. 3 lab; \$ ET*

ETCO 225 Industrial Management (3) Understanding the attributes and skills necessary to be an effective team builder, communicator, supervisor, or manager. Prepares the student for leadership positions in industrial and high technology organizations. *Preq. sophomore standing and GPA of 2.0 or faculty approval*

ETCO 230 Introduction to Robotics (3) Introduction to applications in industry. Emphasis on types, classifications, types of motion, economic impact, and safety. *Coreq. ETCO 220 and ETEM 110; 3 lec. 2 lab; \$ ET*

ETCO 280 The Industrial Archeology of the Ohio River Valley Circa 1750-1870 (3) Classroom, walking tour, and interactive exploration of the industrial archeology of the Ohio River Valley centered on the Hanging Rock Iron and Coal Region of Ohio and Kentucky. This includes the city of Portsmouth, cold and hot blast furnaces in Scioto County and surrounds, foundries and kilns, railroads and canals, and supporting industries. Active historical preservation is also a component of the course.

Computer Engineering Technology

ETEC 102 Structured Programming 1 (4) An introduction to the software development process using a modern structured programming language. Topics include: computer problem solving, program debugging techniques, data abstraction, modularity, parameter passing, and elementary data structures. \$ ET

ETEC 103 Structured Programming 2 (4) Advanced topics and techniques pertaining to the software development process using a modern structured language. Topics include: dynamic memory allocation, data hiding and encapsulation, structures, arrays, pointers, project management, advanced debugging techniques, and an introduction to dynamic data structures. *Preq. ETEC 102; \$ ET*

ETEC 150 Computer System Integration (4) Hardware and software integration techniques for stand alone and networked computer systems. Lecture covers motherboards, floppy drives, hard drives, video boards, network adaptor cards, cabling, and network system software. Lab emphasis on assembling and integrating a networked computer system.

ETEC 199 Special Topics (1-4) Individual or small group study, under the supervision of an instructor, of topics otherwise not available to students. *Preq. advisor approval*

ETEC 200 Assembly Language Programming 1 (4) Machine representation of numeric and non-numeric data, basic CPU architecture, instruction sets, addressing methods, arithmetic operations with integer and floating point data, subroutines, and basic input and output techniques. \$ ET

EETEC 201 Object Oriented Programming 1 (4) The design and development of object oriented programs using a modern object oriented language. Topics covered include classes, methods, polymorphism, encapsulation, and proper object based system design using UML. *Preq. EETEC 103; \$ ET*

EETEC 202 Object Oriented Programming 2 (4) Continuation of EETEC 201. *Preq. EETEC 201; \$ ET*

EETEC 203 Object Oriented Programming 3 (4) Continuation of EETEC 202. *Preq. EETEC 202; \$ ET*

EETEC 241 Microprocessor Circuits 1 (3) The study of small microprocessor based systems. Simple busses, timing, memory systems, and decoding. Techniques for interfacing MSI, LSI, and VLSI chips to system busses. Lab emphasis on expanding and interfacing to a microprocessor based system. *Preq. EETEC 211; 2 lec. 3 lab; \$ ET*

EETEC 242 Microprocessor Circuits 2 (3) Continuation of EETEC 241. PLD, EPROM, and EEPROM uses and programming. Basic I/O techniques, signal conditioning, and interfacing to the physical world. Lab emphasis on interfacing transducers such as temperature sensors and motors to a microprocessor based system. *Preq. EETEC 241; 2 lec. 3 lab; \$ ET*

EETEC 275 Systems Programming (3) A study of computer systems software and its role in modern computing systems. Operational and design details of assemblers, compilers, and linking loaders. Command language programming in modern operating systems. User interface design. *Preq. EETEC 200; 2 lec. 3 lab; \$ ET*

EETEC 280 Applications Programming with Data Structures (4) Advanced computer programming and data organization techniques. Dynamic data structures such as lists, stacks, queues, trees, heaps, tables, and graphs are covered in addition to algorithms involving hashing, sorting, recursion, and searching. Lab emphasis is upon the implementation of these structures and techniques in complete working structured software applications. *Preq. EETEC 103; \$ ET*

EETEC 287 Applications Programming with VBASIC (3) Application design techniques, graphical user interfaces, object module libraries and linking, software testing. Lab emphasis on designing and building a complete GUI based software application. *Preq. EETEC 280 or faculty approval; 2 lec. 3 lab*

EETEC 291 Intermediate Design Lab (3) Provides the time and opportunity for students to work on the design and development of a computer engineering technology application. Enables the student to demonstrate competency in computer engineering technology under the guidance of a faculty mentor. *Preq. sophomore standing; 1 lec. 6 lab*

EETEC 299 Special Topics (1-14) Individual or small group study, under the supervision of an instructor, of topics otherwise not available to students. *Preq. advisor approval*

EETEC 345 Computer Architecture (3) Focus on advanced microprocessor architectures. Lecture topics include internal microprocessor architectures, advanced busses, system components, system interconnect, and comparative microprocessor evaluation. Lab emphasis on building advanced microprocessor based systems. *Preq. EETEC 242; 2 lec. 3 lab; \$ ET*

EETEC 351 Networking and Communications 1 (3) Interfaces from a computer system to external devices which support asynchronous and synchronous communications, flow-control paths, data transfer, packets, and physical interfaces. *Preq. EETEC 241 and 280; 2 lec. 3 lab*

EETEC 352 Networking and Communications 2 (3) A study of the ISO model protocols, logical connections and services, streams and datagrams, LANs, internetworking, routing, and servers. *Preq. EETEC 351; 2 lec. 3 lab*

EETEC 361 Advanced Circuit Analysis 1 (3) Application of calculus to the modeling of systems. Mathematical approach to initial conditions. Introduction to (and application of) integral-differential equations to modeling of circuits and systems. Frequency domain analysis and Laplace transforms are introduced as an analysis tool. Application of PSPICE, BASIC, and/or 'C' computer programming to modeling of different systems. *Preq. ETEM 112 and MATH 202; 2 lec. 3 lab; \$ ET*

EETEC 362 - EETEC 491

EETEC 362 Advanced Circuit Analysis 2 (3) Application of Laplace transforms to system differential equations in the time and frequency domains with sinusoidal and complete harmonic signals. Topics include transfer functions, frequency response, and BODE plots, transients in DC/AC networks, initial conditions, mesh analysis, superposition, the Initial and Final Value Theorems and the Shifting Theorem. A laboratory component is directed at demonstrating the transient effects of both AC and DC stimulus. *Preq. ETEC 361; 2 lec. 3 lab; \$ ET*

EETEC 371 Operating Systems 1 (3) Function, design, and integration of the parts of an operating system. Topics include operating system history, policies for scheduling and page-replacement, memory management, resource allocation, deadlock, starvation, livelock, access control, mutual exclusion, and concurrency. *Preq. ETEC 280; \$ ET*

EETEC 372 Operating Systems 2 (3) Advanced operating system topics are covered through the examination and implementation of the parts of a working operating system. Topics include process synchronization, file systems, secondary storage management, command interpreters, cooperating processes, protection, real-time systems, distributed systems, and security. *Preq. ETEC 371; \$ ET*

EETEC 373 Advanced Operating Systems with UNIX (3) A study of advanced operating systems using UNIX. File systems, processes and process development, remote access using FTP and Telnet and overall system management. *Preq. ETEC 103; 2 lec. 3 lab; \$ ET*

EETEC 399 Special Topics (1-14) Individual or small group study, under the supervision of an instructor, of topics otherwise not available to students. *Preq. advisor approval*

EETEC 410 Compiler Design and Implementation (3) Application of finite state automata as regular expressions to programming language design and analysis of the use of context-free grammars as a formal device for language syntax. Techniques of lexical analysis and parsing (top-down and bottom-up), symbol table management, code generation, and error handling. *Preq. ETEC 216; 2 lec. 3 lab; \$ ET*

EETEC 421 Digital Control Systems 1 (3) A study of the methods used to implement control theory concepts on digital machines. Analog vs. digital machines, open and closed loop systems, block diagrams, PID control algorithms. Lab emphasis on controlling physical devices using computer based control algorithms. *Preq. ETEC 362; 2 lec. 3 lab*

EETEC 422 Digital Control Systems 2 (3) A study of the methods used to implement control theory concepts on digital machines extending the competencies gained from ETEC 421. Includes analog vs. digital machines, open and closed loop systems, block diagrams, and PID control algorithms. Lab emphasis is on controlling physical devices using computer based control algorithms. *Preq. ETEC 421; 2 lec. 3 lab*

EETEC 430 Database Systems (3) A study of database management systems including the design, implementation, and maintenance of databases, applications, and programming techniques. Including the logical and physical representations of hierarchical, simple, and complex data and file relationships and their application in the major data models with a focus on the relational model. *Preq. ETEC 103 or advisor approval; 2 lec. 3 lab; \$ ET*

EETEC 477 Concurrency (3) Principles of concurrent programming. Synchronization and interference. Data parallel algorithms and barriers. The mutual exclusion problem. Semaphores, monitors, and conditional critical regions. Synchronous and asynchronous message passing. Remote procedure call and rendezvous. Exploration of popular process interaction paradigms. *Preq. ETEC 373; 2 lec. 3 lab; \$ ET*

EETEC 483 Software Engineering (3) An introduction to models and issues concerned with the development of high quality software including the life-cycle models, requirements analysis, specification and design techniques, implementation, documentation, configuration management, reliability, verification and validation, and maintenance. *Preq. ETEC 280; 2 lec. 3 lab; \$ ET*

EETEC 491 Design Laboratory 1 (4) A capstone experience in computer engineering technology involving the application of hardware and software components. The student demonstrates computer engineering technology competence by using the deductive method to apply computing concepts from the computer engineering program to an applications design project under the guidance of a faculty mentor. *Preq. senior standing; 1 lec. 9 lab; \$ ET*

ETEC 492 Design Laboratory 2 (4) Continuation of ETEC 491. *Req. ETEC 491; 1 lec. 9 lab; \$ ET*

ETEC 495 Topics in Computing (1-5) A survey of contemporary developments in computer technology focusing on emerging hardware, software, and integrated systems. Discussions of new communications technology, architectures, processors, and applications guide the student in planning for future career decisions. *Req. senior standing or advisor approval; 2 lec. 3 lab; \$ ET*

ETEC 499 Special Topics (1-14) Individual or small group study, under the supervision of an instructor, of topics otherwise not available to students. *Req. advisor approval*

Engineering Graphics

ETEG 105 Blueprint Reading (2) Fundamentals in reading and interpreting engineering drawings, blueprints, and schematics (pneumatic, hydraulic, electrical, and electronic). Using drawings to understand specification sheets, installation details, and to develop bills-of-material. Recognizing and understanding standard drawing symbols and terminology. *2 lec.; \$ ET*

ETEG 110 Engineering Drawing 1 (3) A basic course for students who have had little or no experience in engineering drawing. Develops fundamental principles through actual experience in both freehand sketching and scaled machine drawings. Includes orthographic, multiview drawings, geometric constructions, dimensioning practice, sectional views, and auxiliary views. *2 lec. 3 lab; \$ ET*

ETEG 120 Engineering Drawing 2 (3) Application of basic principles to solve practical engineering problems. Surface design and development and applied descriptive geometry are used to determine the relationship between points, lines, and surfaces in spaces. *Req. ETEG 110 or CADD advisor approval; 2 lec. 3 lab; \$ ET*

ETEG 130 Engineering Drawing 3 (3) Advanced drafting course. Includes detail and assembly drawings, parts lists, thread details and specifications, gear details, classes of fit and tolerances, and geometric dimensioning and tolerancing. *Req. ETEG 120 or CADD advisor approval; 2 lec. 3 lab; \$ ET*

ETEG 299 Special Topics in Engineering Drawing (1-5) Offered as an elective for engineering drawing students. Covers topics of special interest. *Req. instructor permission*

Electromechanical Engineering Technology

ETEM 101 Electro Concepts (4) A course in the concepts of electricity and electronics. Introduction to concepts of Ohm's Law, resistance, capacitance, inductance, power, and energy. Study of reactance, impedance, phasors, and power factors. DC and AC rotating machines are surveyed. Elementary solid state electronics. This course is not for electromechanical or computer engineering technology majors and is not applicable toward an associate degree.

ETEM 110 Introduction to Electricity/Electronics (4) Fundamental principles of DC and AC electricity. An introduction to motors, generators, relays, and transformers. An introduction to electronics with emphasis on process control applications, including PLCs. Not for electro-mechanical or computer engineering technology majors. *Req. MATH 130 or equivalent or EM faculty approval; 3 lec. 3 lab*

ETEM 111 Electrical Fundamentals 1 (DC) (4) An introductory course in the study of electricity. Basic definitions of energy and electricity are introduced which lead to studies of resistance, Ohm's Law, series and parallel circuits, magnetism, simple meters, inductance, and capacitance. Direct current effects only. *Coreq. MATH 130 or equivalent or EM faculty approval; 3 lec. 3 lab; \$ ET*

ETEM 112 Electrical Fundamentals 2 (AC) (4) Simple inductance-resistance and capacitance-resistance transient circuits; studies of alternating current fundamentals, phasor algebra, AC circuit analysis, power factor, and resonance. *Req. ETEM 111 or EM faculty approval; 3 lec. 3 lab; \$ ET*

ETEM 115 Electromechanical Devices (4) An introduction to devices where both electrical and mechanical principles are utilized. Includes DC motors and generators, 3-phase circuits, transformers, induction motors, alternators, and synchronous motors. *Req. ETEM 110 (non-electrical majors); coreq. ETEM 112 (electrical majors) or EM faculty approval; 3 lec. 3 lab; \$ ET*

E T E M 1 2 1 - E T E V 1 1 0

ETEM 121 Electronics 1 (4) Introduction to discrete, bipolar solid state electronic devices and basic electronic circuits, including small signal amplifiers, transistor biasing, equivalent circuits, electronic unregulated DC power supplies, and special solid state devices. *Coreq. ETEM 112 or EM faculty approval; 3 lec. 3 lab; \$ ET*

ETEM 122 Electronics 2 (4) Continuation of ETEM 121. Frequency response; decibels; cascaded, feedback, power, and field effect amplifiers; unijunction transistors; control circuits; four-layer devices; op amps; and regulated DC power supplies. *Preq. ETEM 121 or EM faculty approval; 3 lec. 3 lab; \$ ET*

ETEM 130 Electromechanical Drawing (2) The study of mechanical drawing of both electrical and electronic circuits and components using electrical and electronic symbols. Includes power distribution, logic diagrams, printed circuits, schematics, and pictorial views. *Preq. ETCA 101 and ETEG 101 or EM faculty approval; 1 lec. 3 lab; \$ ET*

ETEM 201 Introduction to Electromechanical Systems (3) An introduction to systems which use both electrical and mechanical principles. Thermal, hydraulic, pneumatic, vacuum, magnetic, and optic systems are utilized to stress the coordinated combination of previously learned concepts. *Coreq. ETEM 122 or EM faculty approval; 2 lec. 3 lab; \$ ET*

ETEM 208 Automation Fundamentals with PLCs (4) A study of electromechanical open and closed loop analog and digital systems. The microcomputer and programmable logic controller are used to interface a variety of input and output transducers to build complete automatic control systems. Emphasis on understanding interfacing feedback signals to process control. *Preq. ETEM 115, 122, and 201; coreq. ETCO 220 and ETEM 211; 3 lec. 3 lab; \$ ET*

ETEM 209 Robotics (3) A survey course in Robotics which studies types of industrial robots, control schemes, and applications. *Coreq. ETEM 208, 211, and ETCO 220, or EM faculty approval; 2 lec. 3 lab; \$ ET*

ETEM 211 Electronic Logic Circuits 1 (4) An introduction to solid state, integrated electronic logic. Practical applications of Boolean algebra, logic gates, binary pulse circuits, number systems, and computer arithmetic. *Preq. ETEM 121 or EM faculty approval; 3 lec. 3 lab; \$ ET*

ETEM 212 Electronic Logic Circuits 2 (4) Continuation of ETEM 211. Integrated circuit applications which include combinational and sequential logic, printed circuits, counters, registers, decoders, signal converters, and an introduction to microcomputers. *Preq. ETEM 211 or EM faculty approval; 3 lec. 3 lab; \$ ET*

ETEM 215 Electromechanical Design (3) Designed to provide the time and opportunity for students to work on the design, fabrication, assembly, and testing of electromechanical devices or systems. Promotes independent study, initiative, and creativity by requiring the student to develop the design with minimal staff supervision. *Preq. ETEM 201 and 211; coreq. ETEM 212; 1 lec. 6 lab; \$ ET*

ETEM 220 Technical Presentations (2) Encompasses all of the principles which have been considered previously in the program. Electromechanical systems are analyzed and presented by the student. A thorough understanding of the applied principles is required. *Preq. sophomore standing and electromechanical faculty approval; 1 lec. 3 lab*

ETEM 299 Special Topics in Electromechanical Engineering Technology (1-5) Individual or small group study, under the supervision of an instructor, of topics otherwise not available to students. *Preq. advisor approval*

Environmental Engineering Technology

EDEV 110 Introduction to Environmental Engineering and Regulations (3) An introduction and overview of the management of environmental restoration and pollution control projects. The development of an appreciation of the many aspects of project coordination. Problem discovery and definition, investigative techniques, work plans, health and safety plans, quality assurance/quality control plans, agency interfacing/permit acquisition, legal regulations, and reporting requirements are discussed. *\$ ET*

- ETEV 120 Laboratory Techniques (4)** A specialized laboratory chemistry course for water/wastewater, air, and solid waste analysis. Course includes collection of samples, appropriate sampling protocols, and record keeping for such tests as heavy metals, F/M ratio, sludge age, fecal coliform, BOD, suspended solids, percent solids, ammonia, chlorine demand, and residual, pH, turbidity, etc. *Preq. CHEM 141; coreq. CHEM 142 and ETEV 110; 3 lec. 4 lab; \$ ET*
- ETEV 130 Water Treatment Techniques (3)** Designed to provide the necessary formal training to allow the student to attempt the State of Ohio Class I Water Operator exam. Emphasizes water sources/availability, water quality criteria, reasons for water treatment, distribution systems, theory of operations, and design applications. Basic water quality tests such as chlorine residual, fluoride, iron, manganese, and nitrate nitrogen are also covered. *Preq. CHEM 141; 2 lec. 3 lab; \$ ET*
- ETEV 199 Special Topics (1-14)** Individual or small group study, under the supervision of an instructor, of topics otherwise not available to students. *Preq. advisor approval; \$ ET*
- ETEV 210 Wastewater Treatment Techniques (3)** Provides the necessary formal training to allow the student to attempt the State of Ohio Class I Wastewater Operator exam. Emphasizes types of treatment, theory of operation, design applications, basic operating tests such as BOD, DO, pH, F/M ratio, sludge age, detention timing, hygiene and public health aspects, sewer systems, and budgetary considerations. *Preq. CHEM 141; 2 lec. 3 lab; \$ ET*
- ETEV 220 Hazardous Waste (3)** An investigation of the state and federal programs for environmental assessments of regulating facilities for the disposal of hazardous wastes and the development of resource recovery programs. The creation, transportation, treatment methods, storage, and disposal of "hazardous wastes" are also studied. *Preq. CHEM 141, ETEV 110, and 210; 2 lec. 3 lab; \$ ET*
- ETEV 230 Introduction to Solid Waste Technology (3)** A study of the long-term environmental impacts, methods of transporting, reduction, and storage of solid waste. *Preq. CHEM 141, ETEV 110, and MATH 201; 3 lec. 3 lab; \$ ET*
- ETEV 240 Industrial Waste Treatment (3)** A study of industrial waste pretreatment requirements, equipment operation and design, testing, and removal systems. *Preq. CHEM 142 and ETEV 220; 2 lec. 3 lab; \$ ET*
- ETEV 250 Fluid Mechanics (3)** Fluid properties, fluid statics, including manometry, submerged surfaces, buoyancy, and stability of floating bodies. The principles of fluid flow, including Bernoulli's and energy equations, energy losses, and pump power. Analysis and design of pipe line systems, open channels, and pump selection. *Preq. MATH 132 and PHYS 201; \$ ET*
- ETEV 260 Automation for Environmental Technology (3)** Complete closed-loop control of analog process systems with PLC interfaces and computer control. Several loops are analyzed, such as flow, chemical feeds, temperature, and dissolved oxygen. *Preq. ETEM 115, ETEV 120, 130, 210, MATH 132, and advisor permission; 2 lec. 3 lab; \$ ET*
- ETEV 270 Industrial Toxicology (4)** A study of the health and safety issues of hazardous and infectious environments. Exposure limits, monitoring, symptoms, and prevention of the spread of common diseases through all forms of waste management are discussed. *Preq. CHEM 142 and ETEV 220; coreq. BIOL 151; 3 lec. 2 lab*
- ETEV 280 Hazardous Waste Operations (OSHA 29 CFR 1910.120-HAZWOPER) (4)** Designed to meet the requirements of OSHA - 29 CFR Part 1910.120(e). Health and safety course for environmental personnel who may be involved in the investigation and remediation of hazardous waste sites. Topics include air monitoring instrumentation, air purifying respirators, SCBA, SARS, protective clothing, confined space entry, decontamination, and simulations of hazardous materials response incidents. Students develop the skills necessary to perform hazardous waste clean-up operations and to minimize risk to their safety and health through hands-on lab experiences. *Preq. ETEV 430; coreq. ETEV 440 or advisor approval; 3 lec. 3 lab; \$ ET*
- ETEV 290 Summer Cooperative Education 1 (4)** First course of a two-course series designed to provide practical work experience on location at various waste treatment or hazmat facilities. The lecture portion is used to develop good work habits along with analytical thinking. *Preq. ETCO 210, ETEV 280, junior standing, and advisor permission*

ETEV 299 - ETEV 422

ETEVE 299 Special Topics (1-14) Individual or small group study, under the supervision of an instructor, of topics otherwise not available to students. *Preq. advisor approval; \$ ET*

ETEVE 310 Thermodynamics (3) Energy analysis of engineering systems using the concepts and laws of thermodynamics. The principle of the mechanical equivalent of heat, behavior, or pure substances, use of thermodynamic property tables, and study of gas mixtures. Application of the Carnot cycle to both heat engines and reversed heat engines. *Preq. ETEVE 250, MATH 201, and PHYS 203*

ETEVE 315 Water Treatment 2 (3) A continuation of ETEVE 130, designed to prepare students for advanced positions in municipal and industrial water treatment facilities. Course includes plant design, chemical feed rates, removal times, and process parameters. *Preq. BIOL 151 and ETEVE 130; coreq. CHEM 200; 2 lec. 3 lab; \$ ET*

ETEVE 325 Wastewater Treatment 2 (3) A continuation of ETEVE 210, designed to prepare students for advanced positions in municipal and industrial wastewater treatment facilities. Course includes plant design, chemical feed rates, and process parameters. *Preq. BIOL 151, CHEM 200, and ETEVE 210; 2 lec. 3 lab; \$ ET*

ETEVE 335 Air Pollution 2 (3) Second course of a two-part series in the air quality control field. Through industrial emissions modeling, emphasis is placed on environmental impact studies and emissions removal. *Preq. GEOG 311 and MATH 201; 2 lec. 3 lab; \$ ET*

ETEVE 345 Management of Hazardous Material (3) Focuses on the handling, storage, transportation, and accident prevention aspects of hazardous materials management. Key EPA, DOT, and OSHA regulatory requirements are examined for industrial safety, containerization, labeling, manifesting, and other handling/shipping concerns. *Preq. ETEVE 220; 2 lec. 3 lab; \$ ET*

ETEVE 355 Hazardous Waste Treatment and Control Technologies (3) A comprehensive examination of treatment and disposal technologies for hazardous wastes. Physico-chemical, biological, stabilization, solidification, and thermal methods are presented. Topics include soil vapor extraction, carbon absorption, steam stripping, chemical oxidation, incinerators, and other technologies. *Preq. ETEVE 220 and CHEM 142; 2 lec. 3 lab; \$ ET*

ETEVE 365 Environmental Risk Analysis (3) Overview of the environmental risk analysis field, including concepts, programs, procedures, and processes. The course introduces and defines the area of risk analysis. Topics include an overview of risk analysis operations, process descriptions, hazard identification, source models, fault tree analysis, consequence analysis, process hazard analysis, and other topics of vital interest to the environmental professional. *2 lec. 3 lab*

ETEVE 390 Summer Cooperative Education 2 (4) Continuation of ETEVE 290. This course provides additional training and practical work experience on location at various waste treatment or hazmat facilities, which are different from those used for ETEVE 290. *Preq. ETEVE 290 and advisor permission*

ETEVE 399 Special Topics (1-14) Individual or small group study, under the supervision of an instructor, of topics otherwise not available to students. *Preq. advisor approval; \$ ET*

ETEVE 410 Engineering Hydrology for Technologists (3) An overview of basic groundwater hydrology, groundwater flow systems, well design, and groundwater management. Emphasis is placed on the environmental aspects of groundwater development and management. *Preq. CHEM 200 and GEOG 112; coreq. MATH 202; 2 lec. 3 lab*

ETEVE 420 Introduction to Geographic Information Systems (3) Introduction to the use of computer aided drafting techniques to document municipal, utility, and governmental information in a graphics format. *Preq. ETCO 115 or 116 or 117 or 150 and GEOL 112; 2 lec. 3 lab; \$ ET*

ETEVE 422 ISO 14,000 Standards and Guidelines (3) Explores the ISO 14,000 guidelines, including environmental management system specifications, guidelines for environmental auditing, environmental labeling, life cycle assessment, evaluation of environmental performance, and guidelines for inclusion of environmental aspects in product standards. *Preq. ETEVE 110 and 440; 2 lec. 3 lab; \$ ET*

ETEVE 425 Solid Waste Disposal 2 (3) Study of the control and management of a solid waste reduction and storage facility. Emphasis on process flows, monitoring, and control. *Preq.* ETEVE 230; *coreq.* MATH 202; 2 lec. 3 lab; \$ ET

ETEVE 430 Statistical Procedures for Analysis of Environmental Data (3) Provides statistical and numerical techniques to analyze environmental monitoring data required for regulatory compliance. Applications include groundwater, soil, air, and others as appropriate. *Preq.* ETEVE 270; 2 lec. 3 lab; \$ ET

ETEVE 435 Environmental Monitoring and Sampling Systems (3) An overview of current EPA monitoring guidelines, processes, and equipment required to perform environmental system assessment and control. Environmental sampling plans are developed in detail. *Preq.* ETEVE 120; 2 lec. 3 lab; \$ ET

ETEVE 440 Environmental Law and Policy (3) A study of American political institutions and a brief history of the American environmental movement and the resulting environmental regulations. Emphasis is on NEPA, RCRA, CERCLA, EPCRA, CAA, CWA, SDWA, HMTA, TSCA, FIFRA, the Clean Water Act, the Clean Air Act, and the Asbestos Hazard Emergency Response Act. *Preq.* ETEVE 220; \$ ET

ETEVE 445 Hazardous Site Remediation (3) A projects course in which students are given a simulated waste site. The student prepares a site assessment, risk assessment, categorization, and permit requirement acquisition. A containment plan, treatment plan, sampling, monitoring, shipping, and storage plan are also developed. The course takes the student through a complete site remediation project. *Preq.* ETEVE 280, 335, 355, 365, 420, 430, 435, and advisor permission; 2 lec. 3 lab; \$ ET

ETEVE 499 Special Topics (1-14) Individual or small group study, under the supervision of an instructor, of topics otherwise not available to students. *Preq.* advisor approval; \$ ET

Instrumentation Technology

ETIN 103 Industrial Electricity (3) Designed to familiarize the student with the National Electrical Code and practices used in industry to install electrical conductors, switching equipment, and overload protection and equipment. Course study includes motors, generators, and machine controls. *Preq.* ETEM 111 and 112; 2 lec. 3 lab; \$ ET

ETIN 111 Industrial Electronics (3) Designed to familiarize the student with industrial electronic circuits, including amplifiers, DC power supplies, and integrated circuits. *Preq.* ETEM 111 and 112; 2 lec. 3 lab; \$ ET

ETIN 120 Process Instrumentation (4) Introduction to measurement and control systems for temperature, pressure, and fluid flow. Dynamic response characteristics of instruments and calibration methods. Introduction to transducers, transmitters, controllers, and control systems. Both electrical and pneumatic systems are included. 3 lec. 3 lab; \$ ET

ETIN 185 Instrumentation Internship (6) Eleven weeks of supervised work experience in industry which relates directly to the student's field of study. Supervisory visits by the instructor are coordinated with periodic evaluations by the industry to critique the performance of the student. 40 lab

ETIN 201 Instrumentation Electronics (4) Designed to familiarize the student with the electronic equipment and devices found in electronic instrumentation. High voltage power supplies, amplifiers, input and output transducers, recording devices, ultrasonics, synchros, telemetering, remote control, and optical electronics are included. *Preq.* ETIN 111; 2 lec. 5 lab; \$ ET

ETIN 202 Programmable Controllers 1 (4) Introduction to basic industrial control circuits and schemes using the programmable controller as a control device. Instruction on the proper methods of programming the controller for the desired scheme. *Preq.* ETIN 111; 2 lec. 5 lab; \$ ET

ETIN 203 Programmable Controllers 2 (4) A continuation of ETIN 202, including more advanced control using the controller as a programmable controller. Proper methods of interfacing the programmable controller to the controlled device and peripheral devices. *Preq.* ETIN 111; 2 lec. 5 lab; \$ ET

ETIN 221 - ETPPL 120

ETIN 221 Instrument Fundamentals (4) Designed to provide the student with a knowledge of instruments. Introduction to the field, shop and industrial safety, care and use of hand and power tools, soldering techniques, reading and interpreting instrumentation drawings, measurement and control devices, final control elements, and standards and calibration. *Preq. ETIN 120; 3 lec. 3 lab; \$ ET*

ETIN 223 Measurement Principles (4) Industrial methods of measuring pressure, temperature, and flow with various types of measuring devices. The theory of operation of manometers, thermometers, strain gauges, and other precision measuring equipment. *Preq. ETIN 201 and 221; 3 lec. 3 lab; \$ ET*

ETIN 224 Industrial Control (4) Introduction to basic industrial control circuits and schemes. Pneumatic, hydraulic, electrical, and electronic control. *3 lec. 3 lab; \$ ET*

ETIN 225 Distributive Control Systems (4) The procedures of using and configuring a distributive process control system. The student is required to implement the control system. *Preq. ETIN 224; 3 lec. 3 lab; \$ ET*

ETIN 251 Biomedical Instrumentation (4) Study of cardiovascular instruments; pacemakers; defibrillators; and respiratory, ultrasound, and other life-supporting and lifesaving instruments. *3 lec. 2 lab; \$ ET*

ETIN 252 Techniques and Devices for Electronic Troubleshooting (4) Instructs the student in procedures for finding malfunctioning cards and components in electronic instruments. Test equipment is used to find the malfunctioning components. *Preq. ETIN 210 and 251; 3 lec. 2 lab; \$ ET*

ETIN 253 Internship 1 Work in Hospital (3) Students work in a hospital with biomedical personnel, under the direct supervision of the hospital. *Preq. ETIN 252; coreq. ETIN 251; 1 lec. 14 lab; \$ ET*

ETIN 261 Instrumentation for Circulatory Systems (3) Study of instruments used in the circulatory system—acoustic, ultrasonic, electronic, and radiologic devices. *Preq. ETIN 252; 2 lec. 2 lab; \$ ET*

ETIN 262 Bio Voltages (3) Study of the origin and usefulness of ECG, ERG, and EEG. *Preq. ETIN 251; 2 lec. 2 lab; \$ ET*

ETIN 263 Internship 2 Work in Hospital (3) Continuation of ETIN 253. Safety testing, preventive maintenance, inspection, troubleshooting, and repair of biomedical equipment under the supervision of the hospital clinical engineer or department supervisor. *Preq. ETIN 253; 1 lec. 14 lab; \$ ET*

ETIN 299 Special Topics in Instrumentation (1-5) Offered as an elective for instrumentation students. Covers topics of special interest. *Preq. instructor permission*

Machining

ETMA 140 Machine Tools (3) The basics of metal chip making technology. Topics include safety, measurements, bench work, drilling, turning, shaping, planing, milling, and grinding. Properties and uses of ferrous and non-ferrous alloys, cutting fluids, welding, and foundry practices. Laboratory experiences include chip making processes and tooling methods. *2 lec. 3 lab; \$ ET*

Plastics Engineering Technology

ETPL 100 Plastics Manufacturing (4) An introductory overview of the different plastic resins, processing methods, and terminology. Lectures cover different types of plastic, identification tests, polymerization, molecular growth, and processing methods. Laboratory experiences in extrusion, injection, thermoforming, compression, and other molding and fabricating operations. *\$ ET*

ETPL 120 Introduction to 3D Drawing Using AUTOCAD® (3) Introduction to 3-D modeling concepts using alternate CADD package(s) to help the student progress into the design of plastics mold cavities. *2 lec. 3 lab; \$ ET*

ETPL 200 Plastics Processing (Injection Molding) (4) Basic topics in the processing of thermoplastic resins. Hands-on operation of injection molding machines and introduction to principles of injection molding processing of thermoplastics. *Preq. CHEM 200, ETPL 205, and PHYS 201; \$ ET*

ETPL 205 Plastics Processing (Extrusion) (4) Basic topics in extrusion and blow molding processing. Hands-on operation in the study of the extrusion and blow molding of thermoplastic resins. *Preq. ETPL 100 and PHYS 201; coreq. CHEM 200; \$ ET*

ETPL 210 Plastics Processing (Thermoforming and Finishing) (4) Study of basic topics involved with thermoforming area of processing and the study of plastic manufacturing methods. Includes secondary operations such as printing, plating, cementing, stamping, and other decoration finishing operations. *Preq. ETPL 100; \$ ET*

ETPL 215 Plastics Processing (Thermosets) (4) Study dealing with processing of thermoset materials. Hands-on operation of thermoset molding machines and introduction to principles of processing thermoset resins. *Preq. CHEM 200 and PHYS 201; \$ ET*

ETPL 220 Plant and Facilities Engineering (4) General overview of plant systems and machinery. Topics include electrical, hydraulic, and pneumatic system operation, process controls, equipment maintenance, and troubleshooting. *Preq. ETPL 100*

ETPL 230 Properties of Polymeric Materials (4) Basic design considerations in use of polymeric materials. The reasons for using designs and polymers are presented using an applications-oriented approach. Extensive usage of tables on properties and shapes. *Preq. CHEM 200, ETPL 100, or plastics faculty approval; 3 lec. 3 lab; \$ ET*

ETPL 235 Statistical Process/Quality Control (4) Study of probability and statistical theory and the relationships of these concepts to applications in a production environment through statistical process/quality control. *Preq. MATH 132; \$ ET*

ETPL 248 Plastics Processing Lab 1 (1) Supervised lab allowing students hands-on operation of injection molding, blow molding, extrusion, and thermosetting machines. *Preq. ETPL 200, 205, and 215; \$ ET*

ETPL 299 Topics in Plastics (1-5) Offered as an elective for plastics students. Covers topics of special interest. *Preq. instructor permission*

ETPL 300 Plastics in Society (3) Study of current trends in the plastics industry. May include study of the Society of Plastics Engineers or the Society of the Plastic Industry and their impact on the industry, legislative bills that affect the industry, policy formation, recycling, waste management, and public policy. *Preq. ETPL 100 or plastics faculty approval (plastics faculty approval waived for students in the one-year certificate program); 3 lec.; \$ ET*

ETPL 310 Plant Layout and Material Handling (3) Principles of plant layout and materials handling, including utilization of workers, materials, and machines for efficient application of all resources. CADD exercises as related to P.L. development. *Preq. ETCA 120 or plastics faculty approval; 2 lec. 3 lab; \$ ET*

ETPL 320 Production Cost Analysis (4) Fundamentals of production analysis, piece part costing, mill costs, assembly costs, direct vs. indirect costing methods, and manufacturing cost control. *Preq. MATH 202; \$ ET*

ETPL 330 Material Science (4) Introduction to a broad field of materials, including metals, ceramics, and wood. Emphasis on their nature and behavior to provide a basis for comparison used in the development of new markets for polymers. *Preq. ETPL 230, MATH 201, and PHYS 203; \$ ET*

ETPL 335 Statistical Process/Quality Control 2 (4) Study of the methods used on SQC and SPC, including X bar and R charts (variables), p and np charts (attributes), interpretation of charts, Pareto analysis, histograms and curve fitting, and Demming's 14 points for quality. *\$ ET*

ETPL 340 Advanced Manufacturing (4) Student selects a processing method and performs SQC/SPC/DOE to determine optimum processing cycle, develops first article inspection report, and presents possible options for capacity planning, scheduling, plant layout, and inventory control. *Preq. ETPL 245; \$ ET*

ETPL 345 - ETRO 213

ETPL 345 Advanced Processing 1 (4) A detailed study of the various theories of processing and polymer rheology. Theoretical aspects of material transfer, melting, mechanisms, and part formation. \$ ET

ETPL 360 Plastic Part Design (4) Study of thermoplastic and thermoset part designs. Assigned projects develop an understanding of design parameters. Emphasis is placed on combining several areas of knowledge to design plastic parts. *Preq. ETPL 230; \$ ET*

ETPL 365 Plastic Part Analysis 1 (4) Design and analysis of plastic parts made using thermoplastic injection molds, extrusion dies, and blow molding using Moldflow Design and Analysis and CAD programs. Includes geometric dimensioning, cams, and other special techniques. May include hot runner systems. *Preq. ETPL 360; 3 lec. 3 lab; \$ ET*

ETPL 370 Plastic Part Analysis 2 (4) Continuation of ETPL 365. *Preq. ETPL 360; 3 lec. 3 lab; \$ ET*

ETPL 435 Statistical Process/Quality Control 3 (4) Study of the methods used in formalized design of experiments. Develops ability to construct, conduct, and analyze a statistically sound experiment. Taguchi's, Plackett's, and Burman's methodologies are studied. Orthogonal arrays, variance, and experiment structure are explored through the use of computer software packages designed specifically for statistical analysis. *Preq. ETPL 335; \$ ET*

ETPL 445 Advanced Processing 2 (4) Continuation of ETPL 345. Integration of previously acquired processing knowledge with the theoretical knowledge acquired in ETPL 345. *Preq. ETPL 345; \$ ET*

ETPL 448 Plastics Processing Lab 2 (1) Senior-level supervised lab allowing students hands-on operation of plastics manufacturing equipment. Includes equipment maintenance and machine set-up experience. *Preq. ETPL 470; \$ ET*

ETPL 453 Advanced Processing 3 (Films and Foams) (4) The processing of plastic films and foams. Topics include fundamentals of foaming plastics; extruded foams; EPS; polyurethane foams; the Mucell Process; blown films, oriented films; multiplayer films; and multi-extrusion. *Preq. ETPL 340; \$ ET*

ETPL 460 Composites (4) Provides a unified view of the composite industry. Topics include raw materials, curing agents, fillers, various fiber reinforcements, and the various processing methods. *Preq. ETPL 215, 230, and 330; \$ ET*

ETPL 470 Senior Project (4) Capstone design class for the plastic curriculum. Students learn CNC programming and basic knowledge to construct a mold for a plastic part. Mold is constructed for design developed and analyzed in ETPL 360, 365, and 370. Study of assembly, machining, and molding of plastic parts. *Preq. ETPL 335 and 370; coreq. ETPL 445; \$ ET*

ETPL 499 Special Topics in Plastics (1-5) Offered as an elective for plastics students. Covers topics of special interest. *Preq. instructor permission*

Robotics

ETRO 211 Robotic Interfacing (4) Study of hardware and software for interfacing programmable controllers, microprocessors, and computer control to a robotic arm with interaction of peripheral machines and equipment. *Preq. ETEM 209 or ETCO 230; 3 lec. 3 lab; \$ ET*

ETRO 212 Robotic Applications (4) Advanced study and training in high technology robot operations and applications with emphasis on continuous and controlled path robots, programmable logic control systems, and production systems and operation. Extended practice in off-line programmable set-up, adjustment, and operation of robotic work cells and materials handling systems. *Preq. ETRO 211; 3 lec. 3 lab; \$ ET*

ETRO 213 Robotic Maintenance & Servicing (4) Instruction in servicing and troubleshooting robotic and peripheral automated systems. Emphasis on mechanics, hydraulics, and associated electrical and electronics. *Preq. ETRO 212; 3 lec. 3 lab; \$ ET*

Web Engineering

ETWB 111 XML 1 (XHTML) (4) Covers developing web pages in HTML and XHTML along with introducing the fundamental concepts behind XML. *Coreq. ETEC 201; \$ ET*

ETWB 112 XML 2 (DOM, SAX, etc.) (4) Covers how to use tools such as DOM, JDOM, and SAX to work with XML documents within an object oriented programming language. *Preq. ETWB 111; coreq. ETEC 202; \$ ET*

ETWB 113 XML 3 (XSLT, DTDs, Schemas) (4) Covers style languages that can be used with XML, such as Cascading Style Sheets (CSS) and eXtensible Style Sheets (XSL). Other XML related technologies are also studied, including DTDs, Schemas, Formatting Objects, XLinks, XPointers, Resource Description Framework (RDF), and Namespaces. *Preq. ETWB 112; coreq. ETEC 203; \$ ET*

ETWB 221 Web Databases (4) Web databases are studied and used to build web sites that automatically serve dynamic content. *Preq. ETEC 103 and ETWB 113; \$ ET*

ETWB 232 Application Servers (4) An application server is used to develop web applications that serve multiple clients such as web browsers and cell phones. *Preq. ETWB 221 and 251; \$ ET*

ETWB 243 Internet Devices (4) Web services are developed that are accessible by the widely diverse types of devices that will be attached to the web—such as cell phones, PDAs, web tablets, smart cards, automobiles, TV set top boxes, watches, refrigerators, and PCs. *Preq. ETWB 232; \$ ET*

ETWB 251 Software Components (4) The development of software components is studied along with how these components are assembled to build applications. *Preq. ETWB 103 and 113; \$ ET*

French

FREN 111 Elementary French 1 (4) Beginning course of a three-quarter, first-year sequence. Basic grammatical concepts and patterns. Emphasis is on development of reading, listening, comprehension, speaking, and writing skills. *GEP \$ H*

FREN 112 Elementary French 2 (4) Continuation of FREN 111. *GEP Preq. FREN 111; \$ H*

FREN 113 Elementary French 3 (4) Continuation of FREN 112. *GEP Preq. FREN 112; \$ H*

FREN 211 Intermediate French 1 (4) An intensive review of grammar and sentence structure and introduction to selected readings in French literature. Oral expression is stressed. *Preq. FREN 113; \$ H*

FREN 212 Intermediate French 2 (4) Continued intensive review of grammar. Sight translation is stressed. Conversational drills include advanced idiomatic expressions. *Preq. FREN 211 or instructor approval; \$ H*

FREN 213 Intermediate French 3 (4) Advanced vocabulary and sentence structure are stressed. Emphasis is on writing and free composition. *Preq. FREN 212 or instructor approval; \$ H*

Geography

GEOG 125 World Geography (4) Concerns world's regions and nations, resource use, cultural groups, and political patterns. Designed to develop an understanding of world affairs and the applications of geography in general.

GEOG 130 Economic Geography (4) Systematic survey of locational economic patterns and their interrelationships. *GEP*

GEOG 201 Cultural Geography (4) Impact of various cultures on landscape, distribution of cultural traits, ecological adaptations, and cultural areas throughout the world. *GEP Preq. ENGL 115S*

GEOG 225 Physical Geography (4) Systematic survey of earth-sun relationships, land forms, climate, soils, and natural vegetation.

ETWB 111 - GEOG 225

GEOG 227 - GEOL 112

GEOG 227 Foundations of Meteorology (4) A survey of the principles and elements of meteorology: composition of the atmosphere, radiation balance, precipitation, global circulation, weather systems and traveling cyclones, weather forecasting, and air pollution and human impacts on local and global climate.

GEOG 230 Urban Geography (4) Study of city function, patterns, and past and current problems confronting the city, including planning, zoning, housing, and urban renewal.

GEOG 242 Geography of Ohio (4) Detailed regional study of physical background, settlement, and economic development.

GEOG 243 Geography of Appalachia (4) A study of Appalachia from a geographical approach, including a detailed examination of physical aspects (climate, soil, vegetation, minerals, and water resources), historical development both past and present, settlement patterns, and economic patterns of the region.

GEOG 299 Special Topics in Geography (1-4) Individual or small-group study, under the supervision of instructor, of topics not otherwise available to students. Separate courses, repeatable for credit. *Preq. GEOG 101, 125, 130, or 201*

GEOG 310 Medical Geography: Geography of Life or Death (4) Relationship between disease and the physical and socio-economic environ. Topics include disease ecology, historical patterns of cholera and plague, tropical disease, weather and health, cancer and heart disease in the U.S., hunger and the environment, distribution of resources, and introduction to facilities location planning.

GEOG 311 Air Pollution (4) Examination of air pollutants and their social and economic impacts, control strategies, and air pollution planning.

GEOG 350 Regional Geography: Geography of North America (4) The U.S. and Canada studied from a geographical perspective, including detailed examination of climate, soil, vegetation, minerals, water resources, historical development, settlement patterns, and economic aspects of the region.

GEOG 351 Regional Geography of the Middle East (4) The Middle East — a cradle of civilization, birthplace of three world religions, crossroads, oil resource area, site of persistent conflict since WWII. The course addresses these aspects within the context of regional geography. **GEP** *Preq. ENGL 115S*

GEOG 399 Special Topics in Geography (1-4) Individual or small-group study, under the supervision of instructor, of topics not otherwise available to students.

GEOG 404 Transportation Geography and Management (4) Examination of the geography of transport routeways and the geographic factors governing their evolution and use. Various modes (e.g. rail, water, highway) are discussed in terms of facilities, environmental impacts, rate structures, and commodities shipped. Decision processes of shippers, carriers, and government are examined. *Preq. one course in GEOG or ECON*

GEOG 499 Special Topics in Geography (1-4) Individual or small-group study, under supervision of instructor, of topics not otherwise available to students. Separate courses are repeatable for credit. *Preq. GEOG 125, 130, or 201*

Geology

GEOL 111 Rocks, Minerals, and Fossils (4) Introduction to earth materials. Strong emphasis on laboratory identification of rocks, minerals, and fossils. Lecture topics include several key earth processes and important geologic theories. Course includes laboratory assignments and a field trip to fossil localities near Portsmouth. **GEP** *3 lec. 2 lab; \$ NS*

GEOL 112 Environmental Geology (4) Analysis of complex interaction between Earth and man. Emphasis on natural hazards such as floods, earthquakes, volcanic eruptions; waste disposal; and groundwater, mineral, and energy resources. Course includes laboratory assignments. **GEP** *3 lec. 2 lab; \$ NS*

GEOL 201 Physical Geology (4) Introduction to earth materials and the processes that shape the Earth's surface. Emphasis on important earth processes such as volcanism, weathering, glaciation, and earthquakes; and theories which have modified our explanation of geologic phenomena. Course includes laboratory assignments and a field trip to Hocking Hills. *GEP 3 lec. 2 lab; \$ NS*

GEOL 202 Historical Geology (4) The history of the Earth and its inhabitants. Emphasis on major physical and biological events that have profoundly affected the Earth, on causal mechanisms of geological events, and on the theories that have changed our interpretation of the Earth's history. Course includes lecture, lab, and field trip to localities in southern Ohio. *Preq. GEOL 201 or instructor permission; 3 lec. 2 lab; \$ NS*

GEOL 290 Seminar in Geology (1-4) Discussion of advanced topics in geology.

GEOL 295 Independent Study (1-4) Independent geology investigation, under the direction of a faculty member.

GEOL 299 Special Topics in Geology (1-4) Individual or small-group study, under the supervision of instructor, of topics not otherwise available to students.

GEOL 301 Invertebrate Paleobiology (4) An introduction to major groups of invertebrates that are commonly preserved in rocks. Emphasis on preservation, morphology, collection, and geological and biological significance of invertebrate fossils. *Preq. GEOL 202 or instructor permission; 3 lec. 2 lab; \$ NS*

GEOL 302 Mineralogy (4) Systematic study of minerals that constitute the Earth. Classification, occurrence, and identification of silicate/nonsilicate minerals. Course builds a foundation for the study of advanced Earth materials and processes. *Preq. GEOL 111 or permission; 3 lec. 2 lab; \$ NS*

GEOL 303 Sedimentary Rocks (4) Advanced study of siliciclastic and carbonate rocks. Emphasis on interpretation of depositional environments of sedimentary rocks by using modern analogues. *Preq. GEOL 202 or instructor permission; 2 lec. 2 lab; \$ NS*

GEOL 390 Seminar in Geology (1-4) Discussion of advanced topics in geology.

GEOL 401 Field Methods (4) Study and use of the essential methods of field observations, description, and mapping. Course consists of lecture and detailed field projects in the Portsmouth area. *2 lec. 4 lab; \$ NS*

GEOL 485 Senior Project (1-4) In-depth study of a selected topic in geology, culminating in the preparation of a senior paper. *Preq. junior or senior standing; \$ NS*

GEOL 490 Seminar in Geology (1-4) Discussion of advanced topics in geology. *Preq. junior or senior standing*

GEOL 495 Independent Study (1-4) Independent geology investigation, under the direction of a faculty member. *Preq. junior or senior standing*

GEOL 499 Special Topics in Geology (1-4) Individual or small-group study, under the supervision of instructor, of topics not otherwise available to students. *Preq. junior or senior standing*

Government

GOVT 101 National Government (4) An analysis of the constitutional basis and development of American politics in light of classical democratic theory and contemporary practices; emphasis on the structures, processes, and functions of the national government.

GOVT 199 Special Topics in Government (1-4) Individual or small-group study, under the supervision of instructor, of topics not otherwise available to students. Repeatable for credit.

GOVT 240 Contemporary Political Ideologies (4) A survey of political thinking, movements, and regimes. Examines the relationship between political visions and the shaping of attitudes, beliefs, and political practice.

GOVT 250 - HIST 113

GOVT 250 Introduction to Political Science (4) This course, required for all social science majors, explains the fundamentals of the field of political science and offers introductory treatments on the four sub-fields of the discipline (i.e., political theory, comparative politics, international relations, and American government). *GE*

GOVT 299 Special Topics in Government (1-4) Individual or small-group study, under the supervision of instructor, of topics not otherwise available to students. Repeatable for credit.

GOVT 310 United States Foreign Policy (4) The conceptual bases underlying the development of post-World War II foreign policy, its changing concerns, and its various modes of policy implementation in selected cases and geographic areas (e.g., the Cold War, the Third World, and North/South issues).

GOVT 320 Third World Politics (4) The individual and collective study of the causes of development and underdevelopment, crisis politics, and the prospects for the future of nations in Asia, Latin America, and Africa. *GE* *Preq. ENGL 115S*

GOVT 330 Mass Media Politics (4) A study of the globalization of the media and its effects on local, national, and international politics; economics; and socialization processes in the United States and other nations.

GOVT 340 European Politics (4) Examines the historical, political, and economic realities of selected nations from an individual and a cross-national perspective with additional attention to the current European Economic Community's supranational integration development process.

GOVT 350 National Policy Issues (4) Study of the politics of policy formation and implementation by the national government in selected areas (e.g., foreign policy, welfare, political economy, and environment). *Preq./coreq. GOVT 250*

GOVT 370 Global Politics (4) Emphasis on international conflict and cooperation, interdependency, and the increasing importance of economic and transnational relations in the contemporary world. A critical examination of a variety of analytic concepts concerning types of international systems and political behavior. *GE* *Preq. ENGL 115S*

GOVT 399 Special Topics in Government (1-4) Individual or small-group study, under the supervision of instructor, of topics not otherwise available to students. Repeatable for credit.

GOVT 401 State of the World (4) A critical analysis of the relationship between humans and their physical environment at the local, regional, and global level. Surveys issues, identifies problems, and examines actual and possible solutions pertinent to this relationship by utilizing an interdisciplinary approach incorporating students' backgrounds from previous social science courses. Required course for all social science majors. *GE* *Preq. junior standing*

GOVT 420 International Political Economy (4) Historical development of the world economy from 1700s to the present with emphasis on international and transnational actors and institutions, dependency and imperialism, and other selected issues and problems (e.g., trade, debt, and finance).

GOVT 499 Special Topics in Government (1-4) Individual or small-group study, under the supervision of instructor, of topics not otherwise available to students. Repeatable for credit. *Preq. eight hours GOVT*

History

HIST 111 American History to 1828 (4) Exploration and colonization; political, social, and economic life of the English colonies to 1763; struggle for independence; constitutional development and the Federalist era; Jeffersonian democracy and the War of 1812; rise of Jackson.

HIST 112 American History, 1828-1900 (4) Jacksonian democracy, territorial expansion, growth of sectionalism, Civil War, reconstruction, impact of expanded Industrial Revolution.

HIST 113 American History Since 1900 (4) Progressive movement, WWI, Republican prosperity, the Great Depression and the New Deal, WWII and problems of the cold war era, turmoil and reform in the 1960s, crisis of confidence in the 1970s, and renewal in the 1980s.

- HIST 199 Special Topics in History (1-4)** Individual or small-group study, under the supervision of instructor, of topics not otherwise available to students.
- HIST 201 Ancient History (4)** A survey of antiquity from the rise of civilization in ancient Sumeria and Egypt to the end of the Roman empire.
- HIST 202 Medieval and Early Modern Europe (4)** A survey of European history from the beginning of the Middle Ages to 1789.
- HIST 203 Modern Europe (4)** A survey of European history from the French Revolution to the present.
- HIST 299 Special Topics (1-4)** Separate courses repeatable for credit. *Preq. HIST 111, 112, and 113, or HIST 201, 202, and 203*
- HIST 301 Formation of the American Nation, 1750-1815 (4)** Causes and consequences of the American revolution, Confederation period and establishment of new constitutional order, survival and development of the republic in an unfriendly world, 1789-1815.
- HIST 303 American Civil War (4)** A survey of the Civil War era from the Compromise of 1850 through Reconstruction. The course focuses on the major events of the war, including the experiences of presidents, generals, diplomats, statesmen, slaves, and “ordinary” soldiers. *Preq. sophomore or higher class standing*
- HIST 305 From FDR to Reagan (4)** A survey of domestic history from the New Deal to the present. The Great Depression and the New Deal, domestic consequences of World War II and the cold war, reform efforts of the 1960s, Vietnam trauma, exhaustion of liberalism in the 1970s.
- HIST 310 Nazi Germany (4)** An examination of Adolf Hitler, Nazi ideology, World War II, the concentration camps, and genocide.
- HIST 320 History of American Foreign Relations (4)** A survey of U.S. foreign relations since 1914. World War I and the Versailles Treaty, interwar efforts to avoid the responsibilities of hegemony, World War II diplomacy and the origins of the cold war, Soviet-American conflict in the Third World, Vietnam War and efforts at detente, exhaustion of the cold war in the 1980s, and possible “end of history.”
- HIST 325 History of Russia (4)** An overview of Russian history since the Age of Peter the Great. Emphasis on the period from the Crimean War to the present, examining the ambivalent modernization efforts of the late Empire, the collapse of the autocracy in WWI, and subsequent triumphs and travails of the Soviet Experiment.
- HIST 330 History of Southern Africa (4)** A survey of the African and European experiences in southern Africa from the 17th century to the present. *GEP Preq. ENGL 115S*
- HIST 350 History of Ohio (4)** A history of the “Buckeye State” from prehistory to the space age, emphasizing economic, social, and political topics.
- HIST 360 East Asian History (4)** A survey of the history of China and Japan, emphasizing the past two centuries. *GEP Preq. ENGL 115S*
- HIST 371 Islamic Religion, Culture, and Civilization (4)** Survey of the cultural legacy of Islam through an integrated look at the religion, social customs, economic practices, arts, and literature. *GEP Preq. ENGL 115S*
- HIST 399 Special Topics in History (1-4)** Individual or small-group study, under the supervision of instructor, of topics not otherwise available to students. *Preq. HIST 111, 112, and 113, or HIST 201, 202, and 203*
- HIST 401 History of Medicine (4)** An in-depth survey of the history of medicine from antiquity to the modern era. Topics include shamanism and magical methods of healing, exorcism, Chinese acupuncture, classical Greek medicine, and the rise of modern dentistry, obstetrics, surgery, and psychiatry.

HIST 410 - JOUR 289

HIST 410 Intellectual History 1 (4) Part one of a course examining humanity's ideas about the cosmos, the earth, and the human species. Topics in this course include creation myths, the history of astronomy, concepts of the afterlife, and the ideas about "imaginary places" (from Atlantis to Shambala). **GEP**

HIST 411 Intellectual History 2 (4) Topics in this course include the history of geology and ideas about the earth, "creation of man" legends and the ideology of Darwinism, "the devil, the Antichrist, and perceptions of evil," ideas about "imaginary creatures" (from unicorns to vampires), and scientific theories about the "end of the world." **GEP**

HIST 420 Middle East in Modern Times (4) An examination of recent conflicts and turmoil in the Middle East through the following sequence: concise overview of Middle East history, relationships between today's turmoil and the development of nationalism and emergence of nation-states, specific conflicts like the Soviet invasion of Afghanistan, Arab-Israeli conflict, and the Gulf war. **GEP** *Preq. ENGL 115S*

HIST 499 Special Topics in History (1-4) Individual or small-group study, under the supervision of instructor, of topics not otherwise available to students. Separate courses repeatable for credit. *Preq. HIST 111, 112, and 113, or HIST 201, 202, and 203*

Interdisciplinary Studies

IDST 199 Special Topics in Interdisciplinary Studies (1-4) A study of interdisciplinary topics not otherwise available to students.

IDST 225S Civilization and Literature 1 (4) This course is an interdisciplinary introduction to the major thoughts important in the development of western civilization. **GEP** *Preq. ENGL 115S*

IDST 226S Civilization and Literature 2 (4) An interdisciplinary introduction to the major thoughts important in the development of American civilization. **GEP** *Preq. ENGL 115S*

IDST 227S Civilization and Literature 3 (4) An interdisciplinary introduction to the major thoughts of various non-western civilizations. **GEP** *Preq. ENGL 115S*

IDST 399 Special Topics in Interdisciplinary Studies (1-4) A study of interdisciplinary topics not otherwise available to students.

IDST 490S Senior Seminar (4) Provides an opportunity for students to place their chosen field of study in an interdisciplinary context with intellectual, ethical, and historical perspectives. The seminar focuses on the synthesis and integration of various concepts by applying them to the analysis and solution of problems chosen in the context of their academic disciplines. Oral and written presentations of a persuasive paper are required. **GEP** *Preq. senior standing and 44 general education program hours*

Journalism

JOUR 105 Introduction to Mass Communication (4) Introduces all forms of mass communication, including newspapers, magazines, radio/television, book publishing, public relations, advertising, and photojournalism. Begins with an analysis of the communication process and ends with media career opportunities.

JOUR 199 Topics in Journalism (1-4) Study of selected newspaper topics not otherwise available. Includes hands-on experience in various newspaper positions. *\$ H*

JOUR 231 News Reporting and Writing (4) Methods of gathering and evaluating news and writing news stories. Practice work includes covering assignments and writing news copy. *Preq. typing proficiency; \$ H*

JOUR 289 Magazine Feature Writing (4) Writing and marketing free-lance magazine articles of various types, including personal narrative, informative, how-to, historical, personality sketch, investigative, and interpretative. Students learn how to generate ideas, get photos, propose article ideas to editors, and survey regional and specialty magazine markets. *\$ H*

JOUR 295 Practicum 1 (2) Permits students interested in the school newspaper and other school-related publications to receive two hours of credit for their work if this work is directly supervised by a member of the Arts/Humanities department or the sponsor of the designated publication. Students must collect their work in a portfolio which will be evaluated by the instructor/sponsor in consultation with the chair of Arts/Humanities. *Req. permission of supervising instructor or publication sponsor; 2 lec. 3 lab; \$ H*

JOUR 299 Topics in Journalism (3) Study of various topics in journalism not otherwise available to students. *\$ H*

JOUR 395 Practicum 2 (2) Permits students interested in the school newspaper and other school-related publications to receive two hours of credit for their work if this work is directly supervised by a member of the Arts/Humanities department or the sponsor of the designated publication. Students must collect their work in a portfolio which will be evaluated by the instructor/sponsor in consultation with the chair of Arts/Humanities. *Req. permission of supervising instructor or publication sponsor; 2 lec. 3 lab; \$ H*

Mathematics

SPECIAL NOTE: Admission to MATH courses is determined either by placement testing or by having successfully completed a prerequisite course. Please see the diagram on page 85. Questions about placement into appropriate courses should be directed to the Department of Mathematical Sciences (351.3301). Inquiries about placement testing should be directed to the Student Success Center (351.3594).

MATH 099 Fundamental Mathematics (4) A brief review of the fundamentals of arithmetic, including addition, subtraction, multiplication, and division of integers and rational numbers. An introduction to the elementary concepts of basic algebra with emphasis on manipulations of algebraic expressions, solutions to simple equations, graphs, and formula rearrangement. (Does not count toward a degree.) *Req. placement*

MATH 101 Basic Algebra (4) A course for students with a good background in arithmetic but little or no background in algebra. Topics include solving linear equations, graphing linear equations in two variables, solving systems of linear equations in two variables, simplifying expressions that involve integral exponents; operations with polynomials. *Req. MATH 099*

MATH 105 Basic Algebra 2 with Geometry (4) A continuation of topics from basic algebra. Rational and radical expressions, graphing lines and linear equations, radical expressions, and an introduction to informal geometry. *Req. MATH 101*

MATH 110S Mathematics Core Course (4) This course addresses questions about the nature and historical development of mathematical thought and knowledge and the impact of mathematics on modern life. The course focuses on problem solving techniques, heuristics, critical thinking, and the collection and interpretation of data. In addition, one or more of the following topics is included: probability, statistical inference, symbolic logic, graph theory, numeration systems, measurement, basic programming, linear programming, and spreadsheet software with business applications. **GEP** *Req. placement or MATH 105; 3 lec. 1 discussion/activity; \$ M*

MATH 125 Business Mathematics (4) Emphasis on estimating answers, percentages, reconciliation of a checking account, mark-up, taxes, depreciation, payroll and payroll deductions, inventory evaluation, financial statements, simple and compound interest on investments and loans, and use of calculators. *Req. placement or MATH 101*

MATH 130 Intermediate Algebra (4) Presentation of a variety of techniques for simplifying algebraic expressions, solving equations and word problems, and graphing. Topics include linear functions, right triangle trigonometry and its applications, rational expressions, rational exponents, and quadratic equations. *Req. MATH 105 or placement*

MATH 131 - MATH 230

MATH 131 Precalculus 1 (4) This college algebra course focuses on functions and their graphs. Students learn the basic properties of linear, polynomial, rational, exponential, and logarithmic functions. Topics also include conditionally defined functions, inverse functions, and operations on functions. Students learn to use functions and graphs as tools for modeling. *GED* *Preq. MATH 130 or placement*

MATH 132 Precalculus 2 (4) This trigonometry course provides an in-depth study of the trigonometric functions, including graphs, equations, identities, and applications. Conic sections are also included. *Preq. placement or MATH 131*

MATH 140 Elementary Topics in Mathematics 1 (4) Problem-solving, sets, concepts of logic, binary operations, systems of numeration, number theory, rational numbers, real numbers, measurement, and use of calculators and computers. *Preq. MATH 110S*

MATH 141 Elementary Topics in Mathematics 2 (4) Basic algebraic work with equations and inequalities in one unknown, systems of equations, metric and nonmetric geometry, coordinate geometry, introduction of statistics and probability, problem-solving, and computer use. *Preq. MATH 140*

MATH 150 Principles of Statistics (4) Introduction to the vocabulary, concepts, formulas, and presentation of statistics as applied to business, education, and science. Topics include measures of central tendency and dispersion, definition of classical probability, probability distributions with emphasis on binomial and normal distribution. Sampling practices and theory, and computer use. This course satisfies the quantitative reasoning requirement of Shawnee State University's General Education Program. *GED* *Preq. placement or MATH 105; \$ M*

MATH 170 Applied Finite Mathematics (4) Applications of mathematical models for students in business, economics, and life and social sciences. Models selected from linear functions and systems, matrices, linear programming, mathematics of finance, probability, markov chains, and game theory. *GED* *Preq. MATH 130 or placement; \$ M*

MATH 190 Brief Calculus with Applications (4) An intuitive introduction to differential and integral calculus with an emphasis on applications in business, economics, and life and social sciences. *GED* *Preq. MATH 130 or 170 or placement; \$ M*

MATH 201 Calculus 1 (4) This is the first course in the calculus sequence. The main topics are functions, limits, derivatives, and applications. This course satisfies the quantitative reasoning requirement of Shawnee State University's General Education Program. *GED* *Preq. placement or MATH 132*

MATH 202 Calculus 2 (4) Second course in the calculus sequence. The emphasis is on integration. Contents include integration of algebraic functions and applications and differentiation and integration of exponential, logarithmic, trigonometric, and hyperbolic functions. *Preq. MATH 201*

MATH 203 Calculus 3 (4) The third course in the calculus sequence. Indeterminate forms, improper integrals, Taylor's Formula and infinite series, plane curves, and polar coordinates. Introduction to vectors. *Preq. MATH 202*

MATH 204 Calculus 4 (4) The last course in the calculus sequence. The emphasis is on multivariable calculus. Contents include some discussion and applications of vector-valued functions, partial derivatives, multiple integrals, and other topics in vector calculus. *Preq. MATH 203*

MATH 220 Discrete Mathematics (4) Introduces the student to various topics from discrete mathematics. Topics include logic; induction; sets, binary relations, and functions; graph theory; proofs; combinatorics and finite probability. This course satisfies the quantitative reasoning requirement of Shawnee State University's General Education Program. *GED* *Preq. MATH 131*

MATH 221 Discrete Mathematics 2 (4) A continuation of MATH 220. In-depth study of graph theory. Topics include basic counting techniques, recurrence equations, trees and spanning trees, and graphs. *Preq. MATH 220 or instructor consent*

MATH 230 Linear Algebra (5) Solutions to linear systems, matrices and matrix algebra, determinants, n-dimensional real vector spaces and subspaces, linear mappings, diagonalization. Techniques and computational skills emphasized. *Preq. MATH 201*

MATH 250 Statistics 1 (4) Introduction of descriptive statistics and probability. Applications of probability distributions with emphasis on binomial, Poisson, and normal distributions. Introduction to interval estimation and hypothesis testing. Computer use in student project applications. This course satisfies the quantitative reasoning requirement of Shawnee State University's General Education Program. *GED* *Preq.* *MATH 201 (preferably with a grade of C or better); \$ M*

MATH 290 Seminar in Mathematics (1-4) Discussion of topics in mathematics.

MATH 299 Special Topics in Mathematics (1-4) Individual or small-group study, under the supervision of instructor, of topics not otherwise available to students.

MATH 300 History of Mathematics (4) Survey from Babylonian and Egyptian mathematics to 20th century mathematics with emphasis on development of algebra, geometry, and number theory. *Preq.* *MATH 201 or permission*

MATH 301 Ordinary Differential Equations (4) An introduction to ordinary differential equations with emphasis on technique and application. Topics include existence and uniqueness of solutions, first order equations, linear differential equations, and systems. Analytical and numerical methods. *Preq.* *MATH 203*

MATH 305 Mathematics Enrichment for the Teacher (4) The use of manipulative models in the classroom. Computer software selection and its integration into the curriculum. Introductory programming. An introduction to mathematics games and how to use them in teaching mathematics to children. *Preq.* *MATH 141 or permission; \$ M*

MATH 320 Foundations of Geometry (4) Introduction to axiomatic mathematics through a variety of geometry types, including a consideration of the postulates of Euclid, surface topology, and finite geometry. The development of plane Euclidean and non-Euclidean geometries using appropriate models and the consideration of various geometric configurations. *Preq.* *MATH 201*

MATH 325 Introduction to Number Theory (4) Selected number systems. Investigation of properties of natural numbers. Topics include proof techniques, prime factorization, Euclidean algorithm, Diophantine equations, congruences, and divisibility. *Preq.* *MATH 201 and 220*

MATH 335 Intermediate Analysis (4) In-depth study of limits, sequence, series, continuity, mean-value theorem, differentiation, and Riemann integration. *Preq.* *MATH 203*

MATH 350 Statistics 2 (4) A course in multivariate analysis. Includes simple and multiple linear regression, analysis of variance, and categorical data analysis. Use of statistical computer software and course projects. *Preq.* *MATH 250; \$ M*

MATH 360 Introduction to Probability (4) Classical probability, probability theory, conditions of probability, random variables and distribution, characteristic function, central limit theorem, and Law of Large Numbers. *Preq.* *MATH 203*

MATH 370 Operations Research 1 (4) An introduction to the general nature, history, and philosophy of operations research. A study of the theory of linear programming, the simplex algorithm, and applications. A series of special linear programming problems, such as optimal assignment, transportation, transshipment, network flow, minimal spanning trees, shortest path, PERT methods, and traveling salesperson. *Preq.* *BUMG 355 or MATH 230 or instructor consent; \$ M*

MATH 371 Operations Research 2 (4) Dynamic programming and integer programming are studied (or finished if started in MATH 370). Stochastic models of operations research such as markov chains, queuing theory, and simulation are studied. *Preq.* *MATH 150 and 370 or instructor consent*

MATH 405 Mathematics Enrichment for the Secondary Teacher (4) Students explore and communicate secondary (grades 7-12) mathematical concepts from an advanced perspective through the use of manipulatives, technology, and exploratory learning. *Preq.* *admission to teacher education program, MATH 220, 230, and 320*

MATH 410 Modern Algebra 1 (4) Treatment of groups, permutations, subgroups, isomorphisms, homomorphisms, and quotient groups. *Preq.* *MATH 220 and 230; MATH 325 also recommended.*

MATH 411 - MLTC 111

MATH 411 Modern Algebra 2 (4) Treatment of rings and fields, subrings, ideals, homomorphisms, isomorphisms, and Galois theory. *Preq. MATH 410*

MATH 420 Matrix Theory (4) Brief review of Linear Algebra. Matrix functions and applications, including linear programming, inner products, diagonalization, generalized inverses, and applications to differential equations and optimization. Numerical linear algebra. *Preq. MATH 230 or permission*

MATH 430 Numerical Analysis (5) Polynomial interpolation and approximation, numerical integration and differentiation, numerical solution to differential equations. Computer use emphasized. This course is strongly recommended for those who are interested in or would like to pursue a career in applied mathematics, actuarial or computer sciences. *Preq. MATH 202 and one computer programming language; MATH 203 and/or 301 are recommended; \$ M*

MATH 440 Mathematical Models (4) Construction and analysis of mathematical models and their use in investigation of physical, chemical, biological, engineering, statistical, social, and environmental problems. This analysis is conducted using calculus-based techniques and applicable computer models. *Preq. MATH 202; \$ M*

MATH 450 Complex Variables (4) Algebra of complex numbers, analytic functions, mappings, Cauchy Integral Theory, Residue Theory, and applications. *Preq. MATH 204*

MATH 460 Real Analysis (4) Topics include set theory, real number theory, compactness, completeness, Lebesgue measure and general introduction of metric spaces. *Preq. MATH 335*

MATH 470 Teaching Mathematics in Grades 7-12 (4) Designed to acquaint students with the practices and problems involved in teaching secondary (grades 7-12) mathematics. Problem solving, inquiry based teaching, and the use of technology are emphasized. General teaching methods, patterns of instruction, and diagnostic techniques, as they apply to the secondary mathematics curriculum, are used in a laboratory context and practiced in field experiences. *Preq. MATH 405, at least 56 credit hours of required mathematical content, and admission to licensure program; coreq. EDAE 400 and 485; 3 lec. 2 lab*

MATH 480 General Topology (4) Concepts of general topological space and metric space, compact and connected spaces, and separation axioms. *Preq. MATH 335*

MATH 490 Advanced Seminar in Mathematics (1-4) Discussion of advanced topics in mathematics.

MATH 495 Undergraduate Research (1-4) Independent mathematics investigation under the direction of a faculty member.

MATH 496 Senior Research Project 1 (1) The first of a three-quarter sequence, taken near the end of the student's bachelor program. The student's in-depth investigation of a mathematical topic culminates in the presentation of a senior paper. *Preq. department permission*

MATH 497 Senior Research Project 2 (2) Continuation of MATH 496. *Preq. MATH 496*

MATH 498 Senior Research Project 3 (1) Continuation of MATH 497. *Preq. MATH 497*

MATH 499 Special Topics in Mathematics (1-4) Individual or small-group study, under the supervision of instructor, of topics not otherwise available to students.

Medical Laboratory Technology

MLTC 111 Medical Laboratory Orientation (2) Introduction to the profession of Medical Laboratory Technology, including history, philosophy, development, educational requirements, current trends, and role and responsibilities of the medical lab technicians. Ethics, employment opportunities, certification and licensure, professional organizations, interpersonal relationships, basic medical terminology, as well as the safe handling of potentially infectious materials. *Preq. admission or alternate status in the medical laboratory program; \$ HS*

MLTC 112 Basic Laboratory Skills (3) Introduction to basic laboratory procedures and techniques. Emphasis is placed on phlebotomy, microscopy, spectrophotometry, pipetting, use of centrifuges, analytical balances, bookkeeping, lab safety, and basic laboratory instruments. Laboratory mathematics, particularly in solution preparations, dilution, calculation of concentrations, and standard curve are included. *Preq. BIOL 151, CHEM 141, and MLTC 111; 2 lec. 3 lab; \$ HS*

MLTC 201 Urinalysis (3) Physical, chemical, and microscopic examination of urine. Theory and applications of various laboratory tests in relation to kidney function. Brief discussion of other important body fluids. *Preq. BIOL 162 (or 310 and 320) and MLTC 112; 2 lec. 3 lab; \$ HS*

MLTC 202 Immunoserology (3) Introduction to basic immunology with emphasis on the principles and applications of serological techniques in diagnostic tests. *Preq. BIOL 162 (or 310 and 320) and MLTC 112; 2 lec. 3 lab; \$ HS*

MLTC 203 Blood Banking (4) Lectures and laboratory procedures in blood banking. Principles of blood grouping and human blood group genetics. Routine procedures for pretransfusion testing, antibody screening, and identification. Donor selection, blood collection, and processing are discussed. Hemolytic diseases of the newborn, preparations of blood components, and their storage and utilization are also introduced. *Preq. MLTC 202; 2 lec. 6 lab; \$ HS*

MLTC 204 Parasitology (1) Introduction to medically important human parasites. Emphasis is on collection, preservation, and laboratory identification. *Preq. MLTC 112; 1 lec. 2 lab; \$ HS*

MLTC 207 Clinical Microbiology (5) Diagnostic procedures for identification of medically important bacteria, viruses, and fungi. Emphasis is on the morphological, cultural, biochemical, and serological characteristics of various pathogenic bacteria, viruses, and fungi. *Coreq. BIOL 350; 3 lec. 6 lab; \$ HS*

MLTC 209 Hematology 1 (4) Basic laboratory methods in hematology, including cell counting, hemoglobinometry, and cell morphology. Detailed studies of blood cell maturation and development. *Preq. BIOL 162 (or BIOL 310) and MLTC 112; 2 lec. 6 lab; \$ HS*

MLTC 210 Hemostasis (2) Study of hemostatic mechanism and hemorrhagic disorders as well as their laboratory evaluations. *Preq. BIOL 162 (or BIOL 310) and MLTC 112; 2 lec. 2 lab; \$ HS*

MLTC 211 Hematology 2 (3) Continuation of MLTC 209 with emphasis on blood cell abnormalities, including anemias, leukemias, and special procedures in the study of blood diseases. *Preq. MLTC 209; 2 lec. 3 lab; \$ HS*

MLTC 212 Clinical Chemistry 1 (4) Principles, practices, and techniques of analyses of chemical components in serum, as well as other body fluids, are studied. Instrumentation associated with specific analyses is introduced. Emphasis on the specific chemical reactions and/or analytical principles, sources of error, quality control, practical applications, and theoretical aspects of the above procedures as related to normal and abnormal states. *Preq. MLTC 112; 2 lec. 6 lab; \$ HS*

MLTC 213 Clinical Chemistry 2 (3) Continuation of MLTC 212. *Preq. MLTC 212; 2 lec. 3 lab; \$ HS*

MLTC 215 Lab Simulation (3) A simulated laboratory environment is designed for students to participate in performing various tests in chemistry, hematology, urinalysis, blood banking, coagulation, and microbiology. Students are required to organize their work assignments, complete the assignments efficiently, and monitor quality control within established criteria. *Preq. successful completion of all MLTC coursework below MLTC 215; 6 lab; \$ HS*

MLTC 216 Medical Technology Seminar (1) Issues and trends in Medical Laboratory Technology, government regulations, professional development, employment opportunities, resume writing, and job-seeking skills are discussed. *Preq. successful completion of all MLTC coursework below MLTC 215; \$ HS*

MLTC 217 Case Studies (1) In conjunction with MLTC 215, students present case studies assigned in MLTC 215 to interpret and evaluate the clinical correlations and significance of the lab data. *Preq. successful completion of all MLTC coursework below MLTC 215; \$ HS*

MLTC 220 - MUSI 170

MLTC 220 Clinical Practicum 1 (4) Eighteen weeks of internship providing a practical application of the skill and knowledge learned during the previous quarters of the curriculum. Students are assigned to accredited hospital laboratories as trainees. The rotation schedule consists of three weeks in hematology-coagulation, four weeks in chemistry, four weeks in microbiology, four weeks in blood banking, one week in urinalysis, and one week of elective. *Preq. completion of all required MLTC courses with a minimum of "C" in the lab and lecture portion of each and a minimum GPA of 2.5; \$ HS*

MLTC 221 Clinical Practicum 2 (8) Continuation of MLTC 220. *\$ HS*

MLTC 225 Special Problems in Med Lab (2) Review of problems and progress during clinical practicum. Students are required to keep a daily log of the scope and degree of activities in the laboratory. The log book is filed with the department at the end of the clinical practicum. Students are also required to participate in laboratory inservice activities (and/or professional meetings if possible). Review exercises during the clinical rotation and a four-day Registry Exam review at the end of the internship are included. *Preq. MLTC 220; \$ HS*

MLTC 226 Special Topics in Med Lab (2) Individualized study of Medical Laboratory Technology in a selected area of interest: laboratory instrumentation, lab management, quality control, laboratory computer, hematology, clinical chemistry, immunology, immunohematology, microbiology, and histology. The selected topic must be approved by the faculty member and the clinical coordinator. The student is required to do library and/or laboratory studies, and a typewritten report on the topic is submitted to the department before the end of the clinical practicum. *Preq. MLTC 220; \$ HS*

Music

MUSI 100 Introduction to Music Theory (3) Developmental theory course used to make up deficiency. Introduction to staff, pitch, rhythmic notations, chords, ear training.

MUSI 101 Music Theory 1 (3) Melodic, harmonic, and rhythmic principles of music and notation. *Preq. theory placement exam*

MUSI 102 Music Theory 2 (3) Continuation of MUSI 101. *Preq. MUSI 101*

MUSI 103 Music Theory 3 (3) Continuation of MUSI 102. *Preq. MUSI 102*

MUSI 105 Ear Training and Sight Singing (3) Music studies based on the structure and aural recognition of intervals and rhythmic, melodic, and harmonic progressions through ear training and written dictation. Analyzes structures of harmony through keyboard application. *Coreq. MUSI 103*

MUSI 120 Introduction to Music Literature (4) Development of listening skills for understanding elements of musical style in historical perspective and significance of music as a fine art. **GEP**

MUSI 121 Introduction to Baroque Music (3) Study of selected works from Baroque style periods through readings, tapes, recordings, and other media. *Preq. MUSI 120 or permission; non-humanities majors*

MUSI 122 Introduction to Music of the Classical and Romantic Periods (3) Study of selected works from the Classical and Romantic style periods through readings, tapes, recordings, and other media. *Preq. MUSI 120 or permission; non-humanities majors*

MUSI 123 Introduction to 20th Century Music (3) Study of selected works of 20th Century, both traditional and electronic, through readings, scores, tapes, recordings, and other media. *Preq. MUSI 120 or permission; non-humanities majors*

MUSI 160 Fundamentals of Music (3) Principles of notation, meter, major, and minor scales, rhythmic and melodic reading, singing, and keyboard.

MUSI 170 Class Voice (1) Basic techniques of voice production: breathing, diction, projection, tone-color, and interpretation. Repeatable for credit—maximum of six quarters. *Preq. music reading; Must be taken in sequence or by permission of instructor.*

- MUSI 180 College Chorus (2)** Repeatable for credit—maximum of six quarters. *Preq. permission of instructor (audition); 4 lab; \$ FA*
- MUSI 181 College Band (2)** Repeatable for credit—maximum of six quarters. *Preq. permission of instructor (audition); 4 lab*
- MUSI 185 Vocal Ensemble (2)** Repeatable for credit—maximum of six quarters. *Preq. permission of instructor (audition); 4 lab; \$ FA*
- MUSI 186 Instrumental Ensemble (2)** Repeatable for credit—maximum of six quarters. *Preq. permission of instructor (audition); 4 lab*
- MUSI 190 Class Piano 1 (1)** Study of scales and finger techniques for beginning players. *\$ FA*
- MUSI 191 Class Piano 2 (1)** Continuation of MUSI 190. *\$ FA*
- MUSI 192 Class Piano 3 (1)** Continuation of MUSI 191. *\$ FA*
- MUSI 220 Music Literature (4)** Survey of musical forms, styles, and performance media from Gregorian to present. Humanities majors. **GEP**
- MUSI 221 Music History and Literature 1 (3)** Study of literature and musical styles to 1600. *Preq. MUSI 220 or permission*
- MUSI 222 Music History and Literature 2 (3)** Study of literature and musical styles 1600-1850. *Preq. MUSI 221 or permission*
- MUSI 223 Music History and Literature 3 (3)** Study of literature and musical styles 1850 to present. *Preq. MUSI 222 or permission*
- MUSI 225 Country and Appalachian Music History 1 (4)** Understanding of the history of Appalachian music and the people, locations, and stories that underlie the music. Examines the evolution and influences of Appalachian music.
- MUSI 226 Country and Appalachian Music History 2 (4)** Continuation and expansion of MUSI 225, including study of ballads, children's songs, dance, and musical families.
- MUSI 227 Country and Appalachian Music History 3 (4)** Continuation and expansion of MUSI 226, including country and Appalachian music and musicians that have not yet been covered in MUSI 225 and 226.
- MUSI 230 Music-Theater (3)** Participation through production or performance of selected musical theater projects.
- MUSI 270 Intermediate Class Voice (1)** Continuation of MUSI 170 series. Repeatable for credit—maximum of six quarters. *Preq. permission of instructor*
- MUSI 280 Intermediate Chorus (2)** Continuation of MUSI 180 series. Repeatable for credit—maximum of three quarters. *Preq. permission of instructor; \$ FA*
- MUSI 299 Topics in Music (1-5)** Study of various music topics not otherwise available to students: folk and country, rock forum. Repeatable for credit—maximum of three quarters.
- MUSI 361 Teaching Music in Elementary Grades (3)** Materials and methods for teaching elementary vocal music. *Preq. MUSI 103*
- MUSI 370 Applied Voice (1)** Repeatable for credit—maximum of six quarters. Recital performance and recital attendance required. *Preq. music concentration; permission of instructor; \$ FA*
- MUSI 371 Applied Piano (1)** Repeatable for credit—maximum of six quarters. Recital performance and recital attendance required. *Preq. music concentration; permission of instructor; \$ FA*
- MUSI 372 Applied Organ (1)** Repeatable for credit—maximum of six quarters. Recital performance and recital attendance required. *Preq. music concentration; permission of instructor; \$ FA*
- MUSI 373 Applied Woodwind (1)** Repeatable for credit—maximum of six quarters. Recital performance and recital attendance required. *Preq. music concentration; permission of instructor; \$ FA*

MUSI 180 - MUSI 373

MUSI 374 - OTAT 110

MUSI 374 Applied Brass (1) Repeatable for credit—maximum of six quarters. Recital performance and recital attendance required. *Preq. music concentration; permission of instructor; \$ FA*

MUSI 390 Conducting (3) Conducting basic beat patterns; conducting techniques for choral groups; style and interpretation. *Preq. music concentration or permission*

Natural Science

NTSC 110S Scientific Reasoning and Methodology (4) Requirement for the General Education Program Option 1. Course addresses scientific reasoning and methodology. GEP credit not allowed for both NTSC 110S and PSCI 110S or NTSC 110S and BIOL 110S. **GEP** \$ NS

NTSC 240 Introduction to Environmental Science (4) Survey of the nature and scope of environmental problems. Emphasis on the physical, biological, and human aspects of environmental science. *Preq. sophomore standing with coursework in the basic sciences, BIOL 151, CHEM 143, or GEOL 201; 3 lec. 2 lab; \$ NS*

NTSC 372 Ohio's Natural Heritage (5) Field and classroom study of Ohio's natural heritage (geology, impact of glaciation, flora, fauna, and natural resources) and the historical impact of human activity on that heritage. Some strenuous, long-distance hiking over rough terrain; course is not suitable for persons unable to accomplish this. Classroom sessions meet for six hours on Fridays; four all-day Friday (7:30 a.m. - 7:30 p.m.) field trips. Enrollment limit 12. **GEP** 3 lec. 3 lab; \$ NS

NTSC 433 Teaching Science in Grades 7-12 (4) Use of a variety of instructional strategies, science curricula, evaluation techniques, and community resources are examined. Establishing and maintaining safety in the classroom, field, and storage areas are emphasized. The use and care for living organisms in an ethical and appropriate manner are experienced. Students participate in the planning and implementation of science experiences for students in the field and clinical setting. *Preq. BIOL 151, CHEM 141, GEOL 111, PSCI 251, EDUC 310, and admission to licensure program; coreq. EDAE 400 and 485; 2 lec. 1 lab/clinical 6 field*

Occupational Therapy Assistant

OTAT 101 Introduction to Occupational Therapy (4) Introduction to the profession of occupational therapy, the roles and functions of occupational therapy personnel, the areas of occupational performance, and the theoretical basis of using goal-directed activities. *Preq. enrollment in OTA program—professional phase; \$ HS*

OTAT 102 Therapeutic Media 1 (3) Introduction to the analysis and therapeutic application of activities. Includes skill development in selected activities, instruction of peers in an activity, and participation in proper care and maintenance of equipment and supplies. *Preq. enrollment in OTA program; \$ HS*

OTAT 103 Disease Pathology 1 (4) Discussion of both physical and psychosocial dysfunctions commonly referred to occupational therapy. Includes the symptoms, etiology, and treatments of various diseases. *Preq. AHN 102, BIOL 101, and OTAT 101/OTST 101; \$ HS*

OTAT 108 Practicum 1 (2) Supervised clinical experience under the direction of qualified personnel in a variety of settings. Emphasis is on developing professional communication skills, learning to accurately document observations, developing an understanding of other health care professionals, and instructing a small group in an activity. See academic requirements of OTA program. *Preq. enrollment in OTA program; \$ HS*

OTAT 109 Applied Anatomy and Kinesiology (2) Study and application of human anatomy and basic movement principles as used in occupational therapy. *Preq. OTAT 101; \$ HS*

OTAT 110 Group Dynamics (2) Study of group behavior. Practice in leading groups, observing group interactions, and participating in various types of groups. *Preq. OTAT 101/OTST 101, PSYC 101, and SOCI 101; \$ HS*

OTAT 203 Occupational Therapy Assistant in Developmental Disabilities (5)

Study of conditions which interfere with normal growth and development. Introduction to the application of occupational therapy in the treatment of developmental disabilities. Emphasis on the role of the O.T. assistant in treatment of developmental disabilities particularly in the public school setting. *Preq. OTAT 108, 109, 110, PSYC 101, and 151; \$ HS*

OTAT 204 Practicum 2 (3) Similar to OTAT 108 but in different types of settings. *Preq. OTAT 108, 109, and 110; \$ HS*

OTAT 205 Therapeutic Media 2 (3) Analysis, adaptation, and therapeutic application of activities not covered in OTAT 102. *Preq. OTAT 101/OTST 101; \$ HS*

OTAT 206 Contemporary Media in Occupational Therapy (2) Analysis, adaptation, and therapeutic applications of “low-tech” and “high-tech” media. Emphasis on computer adaptations, construction of switches, and use of video in patient treatment. *Preq. completion of or concurrent with OTAT 205; \$ HS*

OTAT 208 Practicum 3 (3) Supervised clinical experience under the direction of qualified personnel in a variety of settings. Continuation of skill development of OTAT 204 with additional emphasis on case study, treatment planning, and occupational therapy treatment techniques. *Preq. OTAT 204; \$ HS*

OTAT 209 Occupational Therapy Assistant in Geriatric Program Planning (4)

Introduction to and application of occupational therapy in the treatment of older adults. Emphasis is on developing and implementing both activity and rehabilitative programs in agencies serving the elderly. *Preq. OTAT 210; \$ HS*

OTAT 210 Occupational Therapy Assistant in Physical Dysfunction (5) Exploration of occupational therapy theories in the evaluation and treatment of physically disabling conditions. Lab emphasis on instruction of activities of daily living, work simplification, energy conservation, and fabrication of orthotic and adaptive devices. *Preq. OTAT 109; \$ HS*

OTAT 211 OTA Seminar (2) Discussion of the professional roles and responsibilities of the occupational therapy assistant. Includes orientation to licensure, certification, legal and ethical issues, peer review, and other current professional issues. *Preq. OTAT 208 and 210; \$ HS*

OTAT 212 Occupational Therapy Assistant in Mental Health (4) Exploration of occupational therapy theories in the evaluation and treatment of psychosocial dysfunction. Lab emphasis on the development of observation skills, group dynamics, group leadership, effective communication, and therapeutic use of self. *Preq. OTAT 208, 210, PSYC 101, 151, and SOCI 101; \$ HS*

OTAT 220-221 Clinical Application (8 ea.) Supervised fieldwork placement. Experience in and responsibility for delivery of service to patients/clients. Emphasizes the application of academically acquired knowledge leading to the performance of an entry-level occupational therapy assistant. See academic and clinical requirements of OTA program. *Preq. successful completion of all OTA and other required courses; \$ HS*

OTAT 299 Special Topics in OT (1-3) Provides students an opportunity to gain additional knowledge or experience in a specific area of occupational therapy. *Preq. admission to OT/OTA program and permission of instructor; \$ HS*

Occupational Therapy

OTST 101 Introduction to Occupational Therapy (4) Introduction to the profession of occupational therapy, the roles and functions of occupational therapy personnel, the areas of occupational performance, and the theoretical basis of using goal-directed activities. *Preq. enrollment in OT program-professional phase. \$ HS*

OTST 103 Disease Pathology 1 (4) Discussion of both physical and psychosocial dysfunctions commonly referred to occupational therapy. Includes the symptoms, etiology, and treatments of various diseases. *Preq. AHRN 102, BIOL 101 or 151, and OTST 101; \$ HS*

OTST 110 - OTST 430

- OTST 110 Group Dynamics (2)** Study of group behavior. Practice in leading groups, observing group interactions, and participating in various types of groups. *Preq. OTST 103, PSYC 101, and SOCI 101; \$ HS*
- OTST 205 Therapeutic Media 2 (3)** Analysis, adaptation, and therapeutic application of activities. *Preq. OTST 101; \$ HS*
- OTST 206 Contemporary Media in Occupational Therapy (2)** Analysis, adaptation, and therapeutic applications of “low-tech” and “high-tech” media. Emphasis on computer adaptations, construction of switches, and use of video in patient treatment. *Preq. completion of or concurrent with OTST 205; \$ HS*
- OTST 305 Disease Pathology 2 (4)** The etiology, clinical course, management, and prognosis of congenital, developmental, acute, and chronic disease processes and traumatic injuries. The effect of such conditions on human functioning throughout the life span. Focus is on neuro-muscular, musculoskeletal, and neurological systems. *Preq. admission to OT program or OTAT 103; \$ HS*
- OTST 310 Practicum 1 for OTS (2)** Level 1 Fieldwork. The first competency based fieldwork course to develop professional skills in health service delivery. Students gain an appreciation of the role of occupational therapy in health care. Students are assigned to a variety of agencies serving health care needs. *Preq. admission to OT program and OTST 101; \$ HS*
- OTST 330 Orthotics (3)** Includes theoretical basis and application of orthotics to enhance independent daily living performance in work, play/leisure, and self care. Designing, fabricating, and using orthotic devices. *Preq. admission to OT program and OTST 206; \$ HS*
- OTST 410 OT in Physical Disabilities 1 (4)** Theories, approaches, and principles of occupational therapy programming for physical function throughout the life span. Includes theoretical basis, assessment, and treatment to foster age-appropriate skills in daily living activities, work, and play/leisure. Emphasis is on theory and assessment. *Preq. BIOL 311, OTST 305, and PHYS 201; \$ HS*
- OTST 411 OT in Physical Disabilities 2 (4)** Continuation of theory application covered in OTST 410, with emphasis on treatment planning, adaptations, prevention, health maintenance, and remediation. *Preq. BIOL 314 and OTST 410; \$ HS*
- OTST 412 OT in Mental Health 1 (4)** Theories, approaches, and principles of occupational therapy programming for mental health services throughout the life span. Includes theoretical basis, assessment, and treatment to foster age-appropriate skills in daily living activities, work, and play/leisure. Emphasis is on theory and assessment. *Preq. OTST 305 and PSYC 400; \$ HS*
- OTST 413 OT in Mental Health 2 (4)** Continuation of theory application covered in OTST 412, with emphasis on treatment planning, adaptation, prevention, health maintenance, and remediation. *Preq. BIOL 314 and OTST 412; \$ HS*
- OTST 416 OT in Gerontology (4)** Theories, approaches, and principles of gerontic occupational therapy. Theories of aging, normal physiological and psychological changes of aging, specific diseases and conditions, and common problems of the aging population. Includes quality assurance, consultative role of the OTR in nursing homes, and legal issues regarding aging. *Preq. BIOL 314, OTST 410, and 412; \$ HS*
- OTST 420 Practicum 2 for OTS (2)** Level 1 Fieldwork. The second competency based fieldwork to develop professional skills in occupational therapy service delivery. Focus on observation, evaluation, and documentation of client abilities. Students are assigned to agencies different from those in OTST 310. *Preq. OTST 410 and 412; \$ HS*
- OTST 421 Practicum 3 for OTS (2)** Level 1 Fieldwork. The third competency based fieldwork to develop professional skills in occupational therapy service delivery. Focus on treatment planning and implementation. Students are assigned to agencies different from those in OTST 310 and OTST 420. *Preq. OTST 411, 413, and 420; \$ HS*
- OTST 430 OT in Developmental Disabilities 1 (5)** Theories, approaches, and principles of occupational therapy programming for issues related to normal and abnormal patterns of human development. Evaluation, program planning, and treatment application as it pertains to individuals and their families. *Preq. BIOL 314, OTST 411, 413, and PSYC 151; \$ HS*

OTST 431 OT in Developmental Disabilities 2 (4) Continuation of material covered in OTST 430, with emphasis on neurodevelopmental and sensory integration theory and treatment. *Preq. OTST 430; \$ HS*

OTST 450 Research Designs and Methods in OT (4) Students learn to be consumers of research data, conduct literature searches, examine methods of research design and data collection, and prepare a research proposal related to occupational therapy. *Preq. MATH 150, OTST 411, 413, 416, and 430; \$ HS*

OTST 451 Occupational Therapy Management and Program Planning (4) Occupational therapy service management skills. Includes health care trends, quality assurance, and legal issues. Students develop a model for the delivery of occupational therapy services in a selected agency or facility. *Preq. BUAI 101 or BUIS 101 and OTST 430; \$ HS*

OTST 495 Clinical Application 1 (12) Level 2 Fieldwork. Three months of supervised, in-depth field experience in a selected practice area of occupational therapy. Student is supervised by a Registered Occupational Therapist. *Preq. successful completion of all required courses in OT curriculum; \$ HS*

OTST 496 Clinical Application 2 (12) Level 2 Fieldwork. Three months of supervised, in-depth field experience in a practice area different from OTST 495. Student is supervised by a Registered Occupational Therapist. *Preq. OTST 495; \$ HS*

OTST 497 Clinical Application 3 (Optional) (4, 8, or 12) Level 2 Fieldwork. One to three months of supervised, in-depth field experience in a specialty practice area of occupational therapy. Student is supervised by a Registered Occupational Therapist. *Preq. OTST 496; \$ HS*

OTST 499 Topics in Occupational Therapy (5) A study of topics not otherwise available to students. *\$ HS*

Philosophy

PHIL 105 Rhetoric and Reasoning (4) An introductory course in deductive and inductive reasoning, with particular emphasis upon the analysis, evaluation, and construction of arguments. This course also examines the use of rhetoric in argumentation, especially in advertising, politics, and public speaking.

PHIL 200 Introduction to Philosophy (4) An introduction to some of the central philosophical issues within the Western intellectual tradition from ancient Greece to the present through selected primary texts. *GEP Preq. ENGL 115S*

PHIL 230 Social and Political Philosophy (4) An examination of theories of society and the state that have significantly influenced Western thought. Special emphasis is placed upon the controversy between communitarianism and classical liberalism. *GEP*

PHIL 260 Philosophy of Religion (4) Inquiry into the rationality of religious belief, including the proofs for the existence of God, divine foreknowledge and human freedom, the problem of evil, the epistemic status of mystical experience, and religious epistemology.

PHIL 282 Old Testament (4) Reading and interpretation of selected portions of the Old Testament. Literary, historical, theological, and philosophical interpretations; relation to the New Testament.

PHIL 283 New Testament (4) Reading and interpretation of selected portions of the New Testament. Literary, historical, theological, and philosophical interpretations; relation to the Old Testament.

PHIL 284 East Asian Philosophy (4) A survey of Oriental philosophical traditions including Hinduism, Buddhism, Confucianism, and Taoism. The relationship between Taosim and Native American world views is examined. *GEP Preq. ENGL 115S*

PHIL 299 Special Topics in Philosophy (1-6) Individual or small-group study of topics not otherwise available. May be repeated for credit with permission of the instructor.

PHIL 300 - PHYS 211

PHIL 300 Philosophy and Film (4) Viewing, analysis, and interpretation of international and domestic films and their philosophical, aesthetic, and moral dimensions. **GEP**

PHIL 320S Ethics in Public and Private Life (4) Exploration of the major currents in Western ethical thought, with application to contemporary ethical controversies. Special emphasis is placed upon entering into rational dialogue with moral views other than one's own. **GEP** *Preq. ENGL 115S*

PHIL 330 Ethics and Technology in the 21st Century (4) Introduces the student to the major ethical theories in their historical context and examines technological advances and their ethical implications in two major fields: information technology and biomedical technology. Areas of inquiry include the effects of the Internet and immediate access to information on society and the implications of the human genome project, genetic engineering, and cloning on family planning and health. **GEP** *Preq. ENGL 115S*

PHIL 331 Business Ethics (4) Examination of the relationship between economic and moral constraints. **GEP** *Preq. ENGL 115S*

PHIL 332 Biomedical Ethics (4) Ethical issues in medicine, medical research, and biotechnology; relations within the health team, informed consent; wellness and illness; right to health care; moral implications of bioengineering.

PHIL 334 Environmental Ethics (4) Theories of the environment; alternative views of our responsibility for the environment, including deep ecology; environmental vs. economic values; methods of resolving environmental issues.

PHIL 340 Philosophy of Sport (4) Does the meaning of sport lie in the pleasure of the English gentleman or the egolessness of the Zen master? What do athletes mean when they speak of "expressing" or "realizing" themselves? Can we speak of ourselves as living through our bodies in the same way that we speak of ourselves as living through our intellect or our aesthetic sense? Is sport a metaphor for life? *Preq. sophomore standing*

PHIL 399 Topics in Philosophy (1-4) A study of topics not otherwise available to students.

PHIL 499 Special Topics in Philosophy (1-5) A seminar in selected topics in philosophy. Course content varies from year to year. May be repeated for credit.

Physics

PHYS 099 Fundamental Physics (4) A course intended for special programs and not considered a prerequisite for the college entry-level physics courses. Students desiring a basic course in physics should refer to PHYS 201.

PHYS 201 Physics 1 (Mechanics) (4) Newton's Laws of Motion. Other appropriate topics may be included. Laboratory and demonstrations related to lecture. **GEP** *Preq. MATH 130 or equivalent; 6 hrs., lecture & lab; \$ NS*

PHYS 202 Physics 2 (Electricity and Magnetism) (4) Basic properties of electric and magnetic fields. Other appropriate topics may be included. Laboratory and demonstrations related to lecture. *Preq. PHYS 201; 6 hrs., lecture & lab; \$ NS*

PHYS 203 Physics 3 (Energy) (4) First and second laws of thermodynamics. Other appropriate topics may be included. Laboratory and demonstrations related to lecture. *Preq. PHYS 201; 6 hrs., lecture & lab; \$ NS*

PHYS 210 Astronomy (4) Fundamental ideas of astronomy. Topics include the solar system, stars, galaxies, black holes, and the history of ideas about the universe. **GEP** *3 lec. 3 lab; \$ NS*

PHYS 211 Calculus-Based Physics 1 (4) Introductory survey of mechanics for science and engineering students. Introduces the use of calculus in interpreting physical phenomena. Topics include vectors, kinematics, and Newton's theory of motion. **GEP** *Preq. coreq. MATH 201; 6 hrs., lecture & lab; \$ NS*

PHYS 212 Calculus-Based Physics 2 (4) Introductory survey of thermodynamics for science and engineering students. Introduces the use of calculus in interpreting physical phenomena. Topics include the first and second laws of thermodynamics. *Preq. PHYS 211 or instructor permission; preq./coreq. MATH 202; 6 hrs., lecture & lab; \$ NS*

PHYS 213 Calculus-Based Physics 3 (4) Introductory survey of electricity and magnetism for science and engineering students. Introduces the use of calculus in interpreting physical phenomena. Topics include some of Maxwell's equations. *Preq. MATH 202 and PHYS 212 or instructor permission; 6 hrs., lecture & lab; \$ NS*

PHYS 214 Calculus-Based Physics 4 (4) Introductory survey of waves and oscillations for science and engineering students. Introduces the use of calculus in interpreting physical phenomena. *Preq. PHYS 213; 3 lec. 3 lab; \$ NS*

PHYS 290 Seminar in Physics (1-4) Discussion of advanced topics in physics.

PHYS 295 Independent Study (1-4) Independent physics investigation under the direction of a faculty member.

PHYS 299 Special Topics in Physics (1-4) Individual or small-group study, under the supervision of instructor, of topics not otherwise available to students.

PHYS 300 Modern Physics (4) Introductory survey of modern physics, including spatial relationships, quantum mechanics, and atomic and nuclear physics. *Preq. PHYS 214*

PHYS 390 Seminar in Physics (1-4) Discussion of advanced topics in physics.

PHYS 485 Senior Project (1-4) In-depth study of a selected topic in physics culminating in the preparation of a senior paper. *Preq. junior or senior standing; \$ NS*

PHYS 490 Seminar in Physics (1-4) Discussion of advanced topics in physics. *Preq. junior or senior standing*

PHYS 495 Undergraduate Research (1-4) Independent physics investigation under the direction of a faculty member. *Preq. junior or senior standing; \$ NS*

PHYS 499 Special Topics in Physics (1-4) Individual or small-group study, under the supervision of instructor, of topics not otherwise available to students. *Preq. junior or senior standing; \$ NS*

Physical Science

PSCI 251 Physical Science by Inquiry 1 (4) An inquiry-based (lab-oriented) course in the physical sciences designed primarily for those students who expect to teach the physical sciences (K-12) or those who learn better with a hands-on approach to science. Topics include properties of matter (mass, volume, density, concentration, and solubility) and heat and temperature (calorimetry, phase change, and heat transfer). *GE 6 lab; \$ NS*

PSCI 252 Physical Science by Inquiry 2 (4) A continuation of PSCI 251. Topics include electric circuits (current, voltage, power, energy, d.c. circuits) and light and optics (refraction, reflection, image formation, and color). *GE 6 lab; \$ NS*

PSCI 295 Independent Study (1-4) Independent physical science investigation under the direction of a faculty member.

PSCI 299 Topics in Physical Science (1-4) Individual or small-group study, under the supervision of instructor, of topics not otherwise available to students.

Psychology

PSYC 098 Learning Orientation (4) Techniques for learning definitions, vocabulary, lists, etc. to assist in academic achievement. (The four hours of credit do not apply toward a degree but do apply toward total hours accumulated at the University.)

PSYC 101 - PSYC 361

- PSYC 101 Introduction to Psychology (4)** A study of the individual in terms of maturational, learning, thinking, emotional, motivational, sensory, and perceptual processes. Required course for all social science majors.
- PSYC 105 Career Planning (4)** Exploration of student values, interests, and skills in relation to careers and choosing a college major. Special emphasis on career counseling. Career exploration on the computer is available.
- PSYC 151 Human Growth and Development (4)** Study of the factors affecting human growth and development through the life cycle from infancy to advanced maturity. *Preq. PSYC 101*
- PSYC 199 Special Topics in Psychology (1-4)** Individual or small-group study, under the supervision of instructor, of topics not otherwise available to students. Separate courses repeatable for credit
- PSYC 260 Neurobiology of Behavior (4)** Basic neurology, neurophysiology, and neuropharmacology, with emphasis on how they relate to human behavior. *Preq. BIOL 110S and PSYC 101*
- PSYC 273 Psychology of Human Adjustment (4)** An examination of the individual's adjustments and conflicts in modern society. Considers problem-solving strategies and anxiety reducing behavior. Required course for all social science majors. *Preq. PSYC 101*
- PSYC 290 Psychological Tests and Measurements (4)** Study of the nature, construction, and use of tests and measurements in education, industry, and government, including aptitude, ability, and achievement tests; attitude and rating scales; and opinion surveys. *Preq. PSYC 101*
- PSYC 295 Quantitative Methods (4)** Examination of statistical procedures that are commonly used in psychological research. Students collect real data in a variety of computer-based experiments. Statistical software is used for data analysis. Emphasis is on choosing appropriate statistical procedures based on research design and interpreting results. Taught in the computer lab. *Preq. MATH 150; \$ M*
- PSYC 299 Special Topics in Psychology (1-4)** Courses repeatable for credit. *Preq. PSYC 101 and/or permission*
- PSYC 300 Theories of Personality (4)** Understanding of human personality through examination of psychoanalytic, humanistic, and learning theories and current biologically-based research on personality. *Preq. PSYC 101*
- PSYC 304 Psychology of Learning (4)** Study of learning: classical and instrumental conditioning, discrimination, generalization, verbal, information processing, memory, problem solving, and concept formation. *Preq. PSYC 101*
- PSYC 310 Child Psychology (4)** A survey of the course of development during the first 12 years of life, with emphasis on patterns of physical, cognitive, and mental development; parent/child relations; and the influences of TV and divorce on children. *Preq. PSYC 101*
- PSYC 312 Adolescent Psychology (4)** Study of major theories of adolescent development and explanation of biological, cognitive, social, emotional, and personality processes. Focus is on recent trends and changes in family relationships, adolescent autonomy, educational and vocational roles, moral development and religion, teenage creativity, depression, substance abuse, eating disorders, runaways, suicide, pregnancy, and parenthood. *Preq. PSYC 101*
- PSYC 316 Behavior Problems in Children (4)** Analysis of personal and school-related problems of children. Cases of behavior problems with specific intervention techniques. *Preq. PSYC 101*
- PSYC 340 Psychology of the Adult (4)** Theoretical study of adulthood with an emphasis on the applications of psychological research for a better understanding of later life. Class presentations and discussions cover age-related changes in physical, cognitive, social, and personality development and address issues in adult psychopathology, death, and dying. *Preq. PSYC 101*
- PSYC 361 Industrial Psychology (4)** Applies social/psychological approach to individual's work behavior. Topics include management approaches to organizational processes resulting in productivity and satisfaction, change, turbulent environment, and psychologist's role. *Preq. PSYC 101 or SOCI 101*

PSYC 375 Educational Psychology (4) Psychological foundations of education with emphasis on the teacher as a person and professional, the characteristics of developing students, learning, motivation and discipline, and evaluation strategies. Students are encouraged to apply the newly gained psychological knowledge in solving critical teaching incidents and classroom behavior problems. *Preq. PSYC 101*

PSYC 380 Psychology of Exceptional Children and Youth (4) Psychological study of exceptionality, including the physically, socially, and emotionally handicapped, and the intellectually handicapped and gifted. The psychological characteristics of the exceptional children and youth are investigated, and current programs used to help them are identified and evaluated. *Preq. 12 credit hours of PSYC and/or instructor permission*

PSYC 399 Special Topics in Psychology (1-4) Individual or small-group study, under the supervision of instructor, of topics not otherwise available to students.

PSYC 400 Abnormal Psychology (4) Study of anxiety, mood, psychotic, personality, and psychoactive substance use disorders as well as substance-induced organic mental disorders. Several theories and strategies of psychotherapy are examined during discussion of each disorder. *Preq. at least 12 credit hours of PSYC*

PSYC 405 Death and Dying (4) Focus on increased ability to deal with one's own mortality; skills for working with terminally ill and their families; understanding the complex social system of death in American society; and moral, ethical, and philosophical issues surrounding death. *Preq. PSYC 101 or SOCI 101*

PSYC 410 Psychology of Counseling (4) Survey of the basic concepts and theories of counseling: psychodynamic, behavioral, cognitive, and humanistic. Focus is on individual and group counseling, including school, career, family and marriage, mental health, cross-cultural, crisis intervention, and consultation. *Preq. 20 credit hours of PSYC and/or instructor permission*

PSYC 420 Community Psychology (4) Analysis of historical precedents, epidemiology, community resources, primary prevention programs, and the role of psychologists as agents of social change. *Preq. PSYC 101*

PSYC 430 Experimental Psychology (4) Focuses on research methods in psychology. Fundamental research skills are developed with an emphasis on experimental control and research design. Students design and conduct an independent research project. Strongly recommended for students who are considering graduate work in psychology. *Preq. PSYC 295; 3 lec. 1 lab*

PSYC 440 Environmental Psychology (4) Psychological investigation of the relationship between individual behavior and physical environment with analysis of the impact of crowding, noise, temperature, lighting, pollution, and architecture on individual behavior. *Preq. 16 credit hours of PSYC and/or instructor permission*

PSYC 475 Psychological Study of Contemporary Problems (4) In-depth analysis of current issues, problems, and controversies in psychology. *Preq. 24 credit hours of PSYC (senior students in psychology)*

PSYC 499 Special Topics in Psychology (1-4) Individual or small-group study, under the supervision of instructor, of topics not otherwise available to students. *Preq. senior standing and permission*

Physical Therapist Assistant

PTAT 111 Principles of Physical Therapist Assistant (3) The purpose, philosophy, history, and development of the physical therapy profession, including the function of the American Physical Therapy Association. The development of the PTA, duties, function, legal responsibilities, and scope of practice, including medical ethics and standard documentation. Teaching and learning, cultural sensitivity, rural health care, conflict management, wellness and disability models, basic OSHA training, psychosocial aspects of care. *Preq. admission to PTA program; \$ HS*

PTAT 112 - PTAT 231

PTAT 112 Physical Therapist Assistant Procedures 1 (5) The first of three, sequential PTA procedural courses. Basic bio-physiology and theory of heat, hydrotherapy, cold, massage, body mechanics, burns, isolation techniques, patient positioning, and traction. Interventions in the therapeutic application of these modalities with simple cases for clinic and home. Data collection and standard documentation to support safe and legal care. *Preq. AHNR 104 and PTAT 111; 3 lec. 6 lab; \$ HS*

PTAT 113 Physical Therapist Assistant Procedures 2 (5) The second in a series of three procedural courses, involving the theory and therapeutic application of athermal and thermal agents, such as low and high frequency currents, biofeedback, TENS, Jobst extremity pump/compression therapy, hazardous materials, and diathermy for clinic and home care, as appropriate. Data collection and standard documentation to support safe and legal care. *Preq. PTAT 112; 3 lec. 6 lab; \$ HS*

PTAT 114 Anatomy and Kinesiology (5) Advanced anatomy course designed specifically for the PTA. Palpation of bone and muscular structures in detail as well as a kinesiological and research review of locomotion, work and force, body composition, tissue healing, as applied to PT cases and dysfunctions. *Preq. PTAT 113 and BIOL 311; 3 lec. 6 lab; \$ HS*

PTAT 115 P.T. in Physical Dysfunction (3) Discussion of physical dysfunctions commonly referred to physical therapy. Includes symptoms, etiology, and medical/therapeutic interventions of various diseases for each major human system. Introduction to the *Guide to PT Practice* and review of *Disability/Wellness Models*. *Preq. PTAT 111; \$ HS*

PTAT 116 Neurology for PTA (1) Introduction to the central and peripheral nervous systems as they relate to physical therapy. *Preq. PTAT 115; \$ HS*

PTAT 117 Clinical Practicum and Seminar (2) Introductory experience in clinical settings in which the student performs learned interventions for patient care under close supervision and direction of a licensed physical therapist or assistant. Current topics are discussed in seminar lecture style, including a formal debriefing session, as well as the CPI, OH State Competencies, and documentation/data collection. *Preq. PTAT 111 and 113; 1 lec. 4 clinical; \$ HS*

PTAT 202 Physical Therapist Assistant Procedures 3 (5) The third in a series of three procedural courses, primarily involving the theory and application of principles of muscle testing and goniometry. Includes study and use of rehabilitative interventions relating to prosthetics, orthotics, postural dysfunctions, cardiac conditions, and pre- and post-partum conditions for clinic and home education. Data collection and standard documentation to support safe and legal care. *Preq. PTAT 113; 3 lec. 6 lab; \$ HS*

PTAT 212 Clinical Practicum 1 (4) A full-time three-week intermediate experience in a clinical setting, during which the student performs previously learned, competent interventions for patient care under the close supervision of a licensed physical therapist or assistant. The CPI is the primary performance tool utilized. Includes seminar lectures and debriefing. *Preq. PTAT 114, 115, and 117; 2 lec. 12 clinical; \$ HS*

PTAT 213 Clinical Practicum 2 (4) Intermediate three-week, full-time experience in a clinical setting, performing previously learned, competent interventions under supervision of a licensed physical therapist or assistant. Utilizes the CPI as primary performance evaluation tool. Students submit case history report, generated from the clinical experience. *Preq. PTAT 202, 212, and 231; 2 lec. 12 clinical; \$ HS*

PTAT 214 Clinical Practicum 3 (10) Advanced experience in clinical settings, consisting of two, five-week full-time clinical experiences. Includes complex medical cases in the areas of pediatrics, geriatrics, and rehabilitation. A patient/client case report or an ethical, legal, or financial dilemma is identified and researched for the requisite seminar (PTAT 255) course. Includes debriefing and utilizes the CPI evaluative tool. *Preq. PTAT 213, 232; coreq. PTAT 255; 38 clinical; \$ HS*

PTAT 231 Rehabilitation Procedures 1 (4) The first of two sequential, rehabilitation intervention courses, relating primarily to orthopedic/joint dysfunction. Includes study and application of range of motion, balance, and coordination exercises and flexibility training for clinic and patient home education use. Data collection and standard documentation to support safe and legal care. *Preq. PTAT 113; 3 lec. 3 lab; \$ HS*

PTAT 232 Rehabilitation Procedures 2 (4) The second of two rehabilitation intervention courses, emphasizing applied conceptual knowledge and technical competency for interventions involving complex cases within the central nervous system, peripheral nervous system, and respiratory system. Included are progressive rehabilitation training for stroke and traumatic brain injuries, spinal cord injuries, pediatric conditions, diabetic, advanced orthopedics, and respiratory dysfunctions. Home education and training included, as appropriate. Data collection and standard documentation to support safe and legal care. *Preq. PTAT 231; 3 lec. 3 lab; \$ HS*

PTAT 235 Physical Therapy Trends and Administrative Procedures (2) Identification of concepts, techniques, and administrative skills used in the efficient operation of the physical therapy department in various stages within a total episode of care. The landscape of the health care arena, including the function of cost containment strategies, within managed care systems and networks. Overview of *The Guide to PT Practice*, direct access, outcomes measurement, quality improvement, time management, and resume production. Special emphasis on establishing and maintaining patient data collection. *Preq. PTAT 117; \$ HS*

PTAT 255 PTA Seminar (2) Students present a case study of a patient treated in their PTAT 214 clinical assignments. Specifically, a case history analysis or an ethical, legal, or financial dilemma is identified and researched. Special topics include state board documentation preparation/testing, job placement/career development, and lifelong learning. Debriefing of clinical education PTAT 214 included, along with exit surveying. *Preq. PTAT 213; coreq. PTAT 214; \$ HS*

Radiologic Technology

RDLT 101 Radiologic Technology 1 (4) A course designed to acquaint the student with the goals, philosophies, and organizations of the radiography program and the radiology department. Medical ethics, medicolegal considerations, elementary radiation protection, fundamentals of radiographic exposure, and radiographic positioning of the chest and abdomen are covered. *Preq. admission to radiologic technology program; \$ HS*

RDLT 102 Radiologic Technology 2 (4) Concentration on radiographic positioning of the appendicular skeleton with application of theory in the laboratory. Selected clinical experiences reinforce learning and provide the opportunity to apply principles and techniques. *Preq. RDLT 101; \$ HS*

RDLT 103 Radiologic Technology 3 (3) Concentration on radiographic positioning of the axial skeleton with application of theory in the laboratory. *Preq. RDLT 102; \$ HS*

RDLT 104 Radiologic Technology 4 (3) Concentration on radiographic procedures using contrast media, radiographic practices for surgery, pediatric radiography, and other specialized areas of radiography. *Preq. RDLT 103 and 111; \$ HS*

RDLT 105 Radiologic Technology 5 (3) Continuation of RDLT 104 with emphasis on vascular and neurological examination, including analysis of equipment used. *Preq. RDLT 104; \$ HS*

RDLT 106 Radiologic Technology 6 (3) Examination of advanced radiographic techniques and imaging modalities, quality control, fluoroscopy, image intensifiers, conventional tomography, stereo radiography, xeroradiography, computed tomography, magnetic resonance imaging, ultrasound, and other specialized areas of imaging. *Preq. RDLT 105; \$ HS*

RDLT 107 Radiologic Technology 7 (3) A series of lectures on pathologic conditions and their impact on the radiographic process. Includes student participation in film evaluation and case studies. *Preq. RDLT 106; \$ HS*

RDLT 108 Radiologic Technology 8 (2) Designed as a self assessment of the independent cognitive areas utilized in the clinical situation. *Preq. RDLT 107 and 113; \$ HS*

RDLT 111 Radiologic Physics (4) A study of the fundamentals of matter, electrostatics, electrodynamics, magnetism, rectification, production, and properties of x-rays, x-ray tubes, and x-ray circuitry. *Preq. MATH 130, RDLT 102, and 200; \$ HS*

RDLT 112 Radiobiology and Radiation Protection (3) Lectures on the radiobiological areas of radiation interactions, radiosensitivity, radiation dose/response relationships, early and late radiation effects, radiation protection, and health physics. *Preq. RDLT 201; \$ HS*

RDLT 113 - RPTT 115

RDLT 113 Radiographic Processing (2) Includes discussions of film characteristics, artifacts, film storage and handling, processing room design and function, methods, principles and chemistry of processing systems, silver reclamation, and quality control. *Preq. RDLT 112 and 201; \$ HS*

RDLT 200 Patient Care (3) Provides knowledge and basic skills necessary for care of the patient. Includes medical and professional ethics, medical terminology, and interpersonal relationships. *Preq. RDLT 101; \$ HS*

RDLT 201 Radiographic Exposure (4) Lectures on establishing and manipulating radiographic exposure factors and on the proper utilization of accessory devices such as grids, intensifying screens, and beam limitation devices. Concentration is on overall image quality, as well as factors affecting patient exposure. *Preq. RDLT 104; \$ HS*

RDLT 211 Clinical Experience 1 (2) Practical application of radiologic technology principles, positioning, and techniques with emphasis on upper and lower extremity examinations in the radiology departments of affiliate hospitals. Includes film critique sessions. *Preq. RDLT 102; \$ HS*

RDLT 212 Clinical Experience 2 (3) Continuation of RDLT 211 with emphasis on spine and skull examinations. *Preq. RDLT 211; \$ HS*

RDLT 213 Clinical Experience 3 (3) Continuation of RDLT 212 with emphasis on urographic, biliary, and gastrointestinal examinations. *Preq. RDLT 212; \$ HS*

RDLT 214 Clinical Experience 4 (3) Continuation of RDLT 213 with emphasis on gastrointestinal, portable, and advanced bonework examinations. *Preq. RDLT 213; \$ HS*

RDLT 215 Clinical Experience 5 (3) Continuation of RDLT 214 with emphasis on headwork, surgery, and advanced radiographic examinations. *Preq. RDLT 214; \$ HS*

RDLT 216 Clinical Experience 6 (4) Continuation of RDLT 215 with emphasis on advanced imaging modalities. *Preq. RDLT 215; \$ HS*

RDLT 312 Sectional Anatomy (3) This lab-oriented course is designed to introduce students to human anatomy displayed in sections. Emphasis is on anatomical structures visualized in computed tomography, magnetic resonance imaging, and ultrasonography. *Preq. BIOL 162, 310, or instructor permission; 2 lec. 2 lab*

Reflections on Community Involvement

ROCI 485S Reflections on Community Involvement (4) An outgrowth of the purposes and objectives of the University. The series of activities integral to the community involvement course enhances the education of the student, complements the senior seminar, and promotes reflection on the student's obligation to human beings in need and society at large. *GEQ Preq. ENGL 115S*

Respiratory Therapy

RPTT 101 Basic Patient Care (3) Introduction to respiratory therapy as a profession and to basic clinical assessment and care of patients. Professional duties and responsibilities, ethics and liability, and basic patient care skills (patient assessment, record keeping, patient monitoring, pulmonary care techniques) are included. *Preq. admission to respiratory therapy program; 2 lec. 3 lab; \$ HS*

RPTT 102 Cardiopulmonary/Renal Anatomy and Physiology (5) Detailed presentation of the anatomy and physiology of the pulmonary, cardiac, and renal systems. Topics include basic structure and function, system interactions, and basic pathophysiology with emphasis on the pulmonary system. *Preq. admission to respiratory therapy program; \$ HS*

RPTT 110 Medical Gas Therapy (4) Presentation of topics related to the production, handling, and administration of medical gases, including humidity and aerosol therapy, medical gas therapy, equipment required for their administration, and the indications, contraindications, and hazards of their use. *Preq. RPTT 101 and 102; 3 lec. 3 lab; \$ HS*

RPTT 115 Clinical Application 1 (1) Introduction to the clinical setting, as well as instruction in running EKGs, processing of equipment, body mechanics, and patient transfers, as well as providing an opportunity to practice the skills and techniques learned in RPTT 101. *8 clinical; \$ HS*

- RPTT 120 Perioperative Care (4)** Detailed discussion of respiratory therapy techniques used before and after surgery to minimize complications. Topics include respiratory pharmacology, incentive spirometry, bronchopulmonary drainage, and intermittent positive pressure breathing. *Preq. RPTT 101, 110, and 115; 3 lec. 3 lab; \$ HS*
- RPTT 121 Airway Management (2)** A study of artificial airways, airway obstruction, and defense mechanisms of the lungs. Topics include design, selection, and insertion of artificial airways as well as protective mechanisms of the lungs. *Preq. RPTT 101, 110, and 115; 1 lec. 3 lab; \$ HS*
- RPTT 125 Clinical Application 2 (1)** Continuation of RPTT 115, with emphasis on the application of skills and techniques learned in RPTT 120 and 121. *Preq. RPTT 101, 110, and 115; 8 clinical; \$ HS*
- RPTT 130 Pediatric and Neonatal Respiratory Care (4)** Study of the pathology, pathophysiology, diagnosis, and treatment of diseases of the newborn and pediatric patient. Topics include developmental and comparative anatomy and physiology and specific respiratory care considerations required for these age groups. *Preq. RPTT 120, 121, 125, 131, and 200; \$ HS*
- RPTT 131 Pulmonary Function Testing (3)** Study of the methods used for testing the function of the lungs. Topics include the indications and standards for testing, equipment used, interpretation, and quality control systems. *Preq. RPTT 101, 110, and 115; \$ HS*
- RPTT 132 Arterial Blood Gases/Acid Base (1)** Study of the techniques for collecting and analyzing arterial blood samples and detailed discussion of the interpretation of results. Emphasis on acid-base, fluid, and electrolyte balance and regulation. *Preq. RPTT 120, 121, 125, 131, and 200; \$ HS*
- RPTT 133 Laboratory Procedures (1)** Laboratory practice of the skills discussed in RPTT 131 and 132. *Preq. RPTT 120, 121, 125, 131, and 200; \$ HS*
- RPTT 135 Clinical Application 3 (2)** Continuation of RPTT 125, with emphasis on those skills developed in RPTT 131, 132, and 133. *Preq. RPTT 120, 121, 125, 131, and 200; \$ HS*
- RPTT 200 Pharmacology (3)** Study of the general principles of pharmacology, including drug types, methods of administration, dosage, effects, indications, contraindications, and regulation. Drug groups related to respiratory care are emphasized, including bronchodilators, wetting agents, mucolytics, antibiotics, muscle relaxants, and corticosteroids. *Preq. RPTT 101, 110, and 115; \$ HS*
- RPTT 201 Continuous Mechanical Ventilation (6)** Study of the therapeutic and diagnostic techniques used for patients receiving mechanical ventilatory support. Topics include the selection process for ventilators, indications and hazards of mechanical ventilation, maintenance of patients, respiratory and hemodynamic monitoring, and weaning of patients from ventilatory support. *Preq. RPTT 130, 132, 133, and 135; 5 lec. 3 lab; \$ HS*
- RPTT 202 Pathophysiology (3)** Study of the etiology, diagnosis, pathophysiology, and treatment of some of the most commonly encountered cardiopulmonary diseases. Topics include chronic obstructive pulmonary diseases and common restrictive, pleural, occupational, and cardiac related diseases. *Preq. RPTT 120, 121, 125, 131, and 200; \$ HS*
- RPTT 205 Clinical Application 4 (2)** Continuation of RPTT 135 with emphasis on the skills and techniques learned in prerequisite courses. *Preq. RPTT 130, 132, 133, and 135; 16 clinical; \$ HS*
- RPTT 210 Critical Care (4)** Study of the assessment, monitoring, and treatment of the acutely ill and traumatized patient. *Preq. RPTT 201 and 205; \$ HS*
- RPTT 211 Advanced Cardiopulmonary Assessment (1)** Study of advanced techniques for the monitoring of cardiopulmonary function. *Preq. RPTT 201 and 205; \$ HS*
- RPTT 212 Pulmonary Rehabilitation and Home Care (1)** Study of the care and management of patients receiving pulmonary rehabilitation or home care. Topics include patient selection, education, follow-up, program design, progress assessment, regulatory implications, and equipment. *Preq. RPTT 201 and 205; \$ HS*
- RPTT 215 Clinical Application 5 (3)** Continuation of RPTT 205, with emphasis on the skills and techniques learned in RPTT 201. *Preq. RPTT 201 and 205; \$ HS*

RPTT 220 - SOCI 311

RPTT 220 Seminar (4) Designed to provide final curricular preparation for graduation. Includes oral case presentation, program assessment, systematic content review, and a comprehensive, cumulative student evaluation. *Coreq. RPTT 225; \$ HS*

RPTT 225 Clinical Application 6 (8) Continuation of RPTT 215 with emphasis on skills and knowledge developed in RPTT 130, 201, 210, 211, 212, and 213. *Preq. RPTT 115, 125, 135, 205, and 215; \$ HS*

Sociology

SOCI 101 Introduction to Sociology (4) Studies the nature of human society and factors affecting its development, including concepts of culture, groups, organizations, collective behavior, and institutions. Required course for all social science majors. **GEP**

SOCI 199 Special Topics in Sociology (1-4) Individual or small-group study, under the supervision of instructor, of topics not otherwise available to students.

SOCI 201 Introduction to Social Welfare (4) Overview of the field of social welfare: fundamental concepts and services in social welfare, social policies, historical development.

SOCI 204 Introduction to Social Work (4) Introduces students to the profession of social work. Includes an overview of the historical development of social work as a profession; social work practices with individuals, groups, and communities; and theory and practice of social work.

SOCI 205 Current Social Problems (4) An overview of major perspectives on social problems and their relevance in contemporary life. Topics include poverty, sexism, racism, aging, alienation, crime, human ecology, and colonialism in the third world. *Preq. SOCI 101*

SOCI 206 Social Institutions (4) Examines the major institutions: family, economy, religion, government, and health and medicine. Other important areas of study include populations and urbanization, the natural environment, collective behavior, social systems, and social change.

SOCI 224 Urban Sociology (4) Ecological and nonecological theories are used to study the processes of urbanization and the involvements and problems of the urban community. *Preq. SOCI 101*

SOCI 234 Sociology of Aging (4) Various aspects of aging are examined with special emphasis on theories of aging, demographics, physical, psychological, and sociological aspects of the aging process.

SOCI 299 Topics in Sociology (1-4) Separate courses repeatable for credit on topics not otherwise available to students.

SOCI 303 Introduction to Social Psychology (4) Behavior of the individual as influenced by other individuals, social groups, and culture. Examines group dynamics, leadership, attitude, and group conflict. *Preq. PSYC 101 or SOCI 101*

SOCI 305 Social Work Practice (4) Social work theory, methodology, and application. Areas of study include theory and concept formation, research design, data collection, client-worker relationship, interviewing, and problem-solving. *Preq. SOCI 201 or 204*

SOCI 307 Sociology of Work (4) Examines the history, methods, and context of work. Emphasis on the sociological perspectives of work, industry, and occupations. The future of the workplace is examined. *Preq. SOCI 101*

SOCI 310 Gender Socialization (4) Focuses on the socio-cultural dynamics involved in the socialization process. Examines differential expectations, male and female identity formation, sex roles in the family, occupational stereotypes, and the changing nature of sex roles. *Preq. SOCI 101*

SOCI 311 Human Sexuality (4) An in-depth view of the current status of human sexuality in the U.S. Examines current research; modes of sexual expression and enhancement; physiological, sociological, and psychological basis of human sexuality; sexual variations; and sex ethics. *Preq. SOCI 101*

- SOCI 312 Sociology of Religion (4)** General theories concerning the place of religion in social processes. Religion and its place in the modern world, secularization, fundamentalism, new movements; religion in relation to class, ethnicity, gender, politics, and education. Durkheim's work on religion as the basis of social order and Weber's work on religion and the rationalization process are emphasized. *Preq. SOCI 101*
- SOCI 320 Sociology of Culture (4)** Introduction to the fascinating and complex concept of culture, which is shown to vary in complexity, inventiveness, cohesion, and totality. Various theories of culture are explored. This course reveals how culture has developed over history, with special emphasis on industrialization and the postmodern world. *Preq. SOCI 101*
- SOCI 325 Sociology of the Family (4)** Historical perspective for understanding American family systems. Of central concern are the contemporary marriage process and context, family relationships, sexuality, family dysfunctions, and changes. *Preq. SOCI 101*
- SOCI 326 Small Group Dynamics (4)** Analysis of small-group structure and processes; examination of roles, interpersonal relations, and leadership; and current theory and research on small group interaction. *Preq. SOCI 101*
- SOCI 330 Social Theory (4)** A study of major classical and contemporary sociological theories and their exponents. *Preq. SOCI 101*
- SOCI 340 Sociology of Appalachia (4)** Intensive study of Appalachia from sociological perspective. Emphasizes demography of Appalachia, sub-cultural characteristics, religion, arts and crafts, social change, and community power in Appalachia. *Preq. SOCI 101 or by permission*
- SOCI 380 Sociological Methods (4)** Overview which includes scientific method, measurement, experimentations, survey research, observational methods, case study techniques, and content analysis. *Preq. SOCI 101*
- SOCI 399 Special Topics in Sociology (1-4)** Individual or small-group study, under the supervision of instructor, of topics not otherwise available to students.
- SOCI 400 Complex Organizations (4)** Sociological analysis of complex organizations. Topics include theories, types of organizations, organizational change and conflict, and research in organizations. *Preq. SOCI 101*
- SOCI 403 Field Experience in Social Work (4)** Controlled experience in a social work setting supervised by a qualified professional in an established agency. Designed to expose students to realistic conditions and "hands-on" learning. *Preq. SOCI 204 and 305*
- SOCI 410 Social Stratification (4)** Analyzes stratification in the U.S. and other societies, focusing on income and wealth, role of family and education on social mobility, and inequality and influence of social class on public policy. *Preq. SOCI 101*
- SOCI 425 Industrial Sociology (4)** Focuses on the growth of technology in the U.S. Emphasizes the social organization of industry, life in the work place, and the organizational culture. *Preq. SOCI 101*
- SOCI 429 Contemporary Minority Relations (4)** Basic approaches are used to analyze American minority groups and their contemporary situation. Special emphasis is placed on patterns of prejudice and discrimination as well as the dynamics of race relations. *Preq. SOCI 101*
- SOCI 435 Teaching Social Studies in Grades 7-12 (4)** Provides preservice teachers with essential experiences in theory and practice for teaching social studies students, ages 12 through 21. Instructional strategies and design, classroom management, differentiated learning needs, and implementation are addressed in field and clinical practice. *Preq. admission to licensure program, EDAE 385, social studies education core; coreq. EDAE 400 and 485*
- SOCI 444 Social Deviance (4)** Examination of the concept of deviance in sociology and its implications for the study of contemporary social behavior. How people develop a concept of some being different from others and act on this definition. Possible topics include mental illness, crime, sexual deviance, nonconformity, and subcultures of deviance. *Preq. SOCI 101*

SOCI 450 - SPCH 299

SOCI 450 Sociology of Occupations and Professions (4) Sociological analysis of contemporary occupations and professions in the U.S., social stratifications in the workplace, technology, and the individual in the workplace. *Preq. SOCI 101*

SOCI 499 Special Topics in Sociology (1-4) Individual or small-group study, under the supervision of instructor, of topics not otherwise available to students. Separate courses repeatable for credit. *Preq. SOCI 101*

Social Sciences

SOSC 110S Foundations of Social Science (4) Introduction to the methods and concerns of social science. Studies perspectives of anthropology, economics, history, geography, political science, psychology, and sociology as related to specific themes or topics. **GEP**

SOSC 370 Alternative Religions and Cults (4) An analysis of nontraditional religions, their histories, beliefs, and ethics. Apocalyptic, racist, eastern, Magickal, Neo-Pagan, Satanic, UFO, and sexual cults are examined.

Spanish

SPAN 111 Elementary Spanish 1 (4) Development of comprehension, speaking, reading, and writing skills in a cultural context. Basic grammar. Lab required. Initial course of three-quarter, first-year sequence. **GEP** \$ H

SPAN 112 Elementary Spanish 2 (4) Continuation of SPAN 111. **GEP** *Preq. SPAN 111; \$ H*

SPAN 113 Elementary Spanish 3 (4) Continuation of SPAN 112. **GEP** *Preq. SPAN 112; \$ H*

SPAN 211 Intermediate Spanish 1 (4) Offers selected readings in Hispanic issues and literature to continue the development of communicative skills. Lab required. *Preq. SPAN 113 or 2-3 years of high school Spanish; \$ H*

SPAN 212 Intermediate Spanish 2 (4) Continuation of SPAN 211. *Preq. SPAN 211 or instructor's approval; \$ H*

SPAN 213 Intermediate Spanish 3 (4) Emphasizes the ability to read with detailed understanding, creative and accurate use of vocabulary items, use of subordinate structures in oral communication, and the ability to communicate in writing using complex sentence structures. *Preq. SPAN 212 or instructor's approval; \$ H*

SPAN 311 Composition and Conversation (4) A follow-up to SPAN 213 with special emphasis on oral proficiency and applied grammatical concepts. In preparation to reading and writing, contemporary videos and films are used to stimulate discussion. *Preq. SPAN 213 or fluency in Spanish communicative skills*

SPAN 399 Special Topics (1-4) Designed for native speakers of Spanish or nonnative speakers who have acquired communicative skills in the language. The course analyzes the work of contemporary Latin-American writers, as well as Hispano-American writers in the U.S. *Preq. native speaker fluency in communicative skills (listening, speaking, reading, and writing)*

Speech

SPCH 103 Public Speaking and Human Communication (3) Principles of public speaking and practice in presenting informative and persuasive speeches with emphasis on the human communication process.

SPCH 215 Group Discussion (4) Study of structure and internal dynamics of small groups, nature and functions of leadership and group participation, and problem solving and decision making. Frequent participation in group discussion activities.

SPCH 220 Oral Interpretation of Literature (4) Techniques of oral interpretation and development of adequate intellectual and emotional responsiveness to meaning of literature.

SPCH 299 Topics in Communications (1-4) Study of various topics not otherwise available to students. Repeatable for credit.

Athletic Training

SSAT 220 Introduction to Athletic Training (3) Introduces the profession of athletic training, the roles and functions of the certified athletic trainer, and standards of practice of the National Athletic Trainers Association and the State of Ohio Athletic Trainers Licensing Board. This course covers the educational preparation and employment opportunities for athletic training as well as the foundations of the prevention, assessment, treatment, and rehabilitation of athletic injuries.

SSAT 222 Taping and Strapping Laboratory (2) Study of strapping and taping techniques, and fitting of protective equipment commonly used in athletics or for the physically active. *\$ Ed*

SSAT 224 Bracing and Splinting Laboratory (2) Study of the principles and procedures of applying various bracing and splinting materials to the physically active population. Topics include construction of orthotics and orthopedic appliances and fitting of protective equipment commonly used in the field of athletic training. *Preq. SSAT 220 and 222; \$ Ed*

SSAT 227 First Aid (4) Provides information and practical experience dealing with hemorrhaging, traumatic shock wounds, respiratory failure, serious illnesses, transportation of the sick and injured, cardiopulmonary resuscitation, splinting of broken bones, hypothermia, specific injuries, choke-saving, poisoning, burns, heat illnesses. Students are certified in CPR and first aid (infant through adult) through the American Red Cross.

SSAT 310 Athlete Health Maintenance (4) Study of modern health concerns of today's physically active population. Focus is on drug use/misuse, ergogenic aids, sports nutrition, and eating disorders. *Preq. sophomore rank*

SSAT 320 Prevention and Assessment of Upper Extremity Injuries (3) Study of techniques in prevention, assessment, and management of common upper extremity injuries in athletics. *Preq. HPER 220 and acceptance into athletic training program*

SSAT 322 Prevention and Assessment of Lower Extremity Injuries (4) Study of techniques in evaluating, preventing, and managing common lower body injuries and illnesses in athletics. *Preq. HPER 222 and acceptance into athletic training program; \$ Ed*

SSAT 324 Prevention and Assessment of Head, Neck, and Spinal Injuries (4) Study of techniques in evaluating, preventing, and managing athletic injuries to the head, neck, and spine.

SSAT 325 Rehabilitation of Athletic Injuries (4) Study of principles and procedures of therapeutic exercises. Topics include muscle testing, goniometry, flexibility, and progressive resistance exercises in the rehabilitation of common injuries occurring in athletics. *Preq. HPER 320 and acceptance into athletic training program*

SSAT 326 Therapeutic Modalities in Sportsmedicine (4) Theory and therapeutic application of modalities such as cryotherapy, thermotherapy, low and high volt electrical currents, diathermy, intermittent compression, traction, and massage in the rehabilitation of athletic injuries. *Preq. HPER 320 and acceptance into athletic training program*

SSAT 396 Practicum 1 in Athletic Training (3) Application of theories and techniques of athletic training in a variety of on campus clinical settings. Classroom periods focus on the discussion of case studies, special procedures and techniques, and problem solving from the students' clinical experiences. *Preq. HPER 320, 322, and admission to the athletic training program*

SSAT 397 Practicum 2 in Athletic Training (3) Continuation of SSAT 396. Further application of theories and techniques of athletic training in a variety of on campus clinical settings. Classroom periods focus on the discussion of case studies, special procedures and techniques, and problem solving from the students' clinical experiences. *Preq. SSAT 396 and admission to the athletic training program*

SSAT 398 Practicum 3 in Athletic Training (3) Continuation of SSAT 397. Further application of theories and techniques of athletic training in a variety of on campus clinical settings. Classroom periods focus on the discussion of case studies, special procedures and techniques, and problem solving from the students' clinical experiences. *Preq. SSAT 397 and admission to the athletic training program*

SSAT 220 - SSAT 398

SSAT 420 - SSPE 106

SSAT 420 Physiology of Exercise (4) Study of the physiological response of the cardiovascular, respiratory, endocrine, neural, and muscular systems in the human body during exercise. *Req. BIOL 162, 310, and 311*

SSAT 422 Prevention and Assessment of Non-Orthopedic Injuries (4) Study of techniques in prevention, assessment, and management of common non-orthopedic injuries and illnesses in athletics. *Req. SSAT 222*

SSAT 428 Athletic Training Administration (4) Study of standards, policies, and procedures in the organization and administration of an athletic training program.

SSAT 496 Practicum in Athletic Training 4 (3) Level III Fieldwork. 12 weeks of supervised in-depth field experience in a hospital based, physician office, or private practice clinical setting. Students are on site 20 hours each week. Summative assessment includes a combination of performance checklists and evaluations by the on-site clinical supervisor. *Req. completion of all athletic training program level I and II competencies*

SSAT 497 Practicum in Athletic Training 4 (3) Level III Fieldwork. 11 weeks of supervised in-depth field experience in a hospital based, physician office, or private practice clinical setting. Students are on site 20 hours each week. Summative assessment includes a combination of performance checklists and evaluations by the on-site clinical supervisor. *Req. completion of all athletic training program level I and II competencies*

SSAT 498 Practicum in Athletic Training 4 (3) Level III Fieldwork. 11 weeks of supervised in-depth field experience in a hospital based, physician office, or private practice clinical setting. Students are on site 20 hours each week. Summative assessment includes a combination of performance checklists and evaluations by the on-site clinical supervisor. *Req. completion of all athletic training program level I and II competencies*

Sports Studies Fitness Development

SSFD 261 Principles of Personal Fitness (2) Presents scientific information concerning the need for physical activity and a personal fitness prescription. Provides background information on the eleven parts of fitness. Students are shown step-by-step how to work out a lifetime fitness program that meets their needs and interests.

SSFD 440 Exercise Prescription (4) A study of the application of exercise prescription for individuals varying in age, physique, and initial fitness levels. *Req. BIOL 162, 310, 320, SSAT 420, and SSFD 261*

SSFD 450 Exercise Testing and Measurement (4) A study of the theory and application of graded exercise testing and measurement in the evaluation of physical activity. *Req. SSFD 440*

SSFD 490 Internship in Fitness Development (12) Practical experience in off-campus health club or fitness center under direct supervision of certified personal fitness trainer or exercise physiologist. Requires 20 hours per week, 200 hours per quarter. *Req. SSFD 450 and senior rank*

Health, Physical Education, and Recreation

SSPE 100 Dance: Concert and Recreational (1) Demonstration of various forms of dance and appreciation of their development.

SSPE 103 Introduction to Human Nutrition (2) Study of nutrients, nutritional diets, deficiencies, and the role of nutrition in promoting health.

SSPE Physical Education Activities (1) Basic rules and fundamentals for each of the following activities. Special emphasis on strategies, team, and individual play. An appreciation of each of the activities is developed to carry over into later life. All courses graded on pass/no-credit basis only.

SSPE 104 Beginning Table Tennis

SSPE 105 Archery

SSPE 106 Beginning Ballet 1

SSPE 107 - SSPE 203

- SSPE 107 Beginning Ballet 2
 SSPE 111 Basketball
 SSPE 113 Billiards
 SSPE 115 Bowling
 SSPE 116 Gymnastics
 SSPE 117 Volleyball \$ Ed
 SSPE 119 Walleyball \$ Ed
 SSPE 120 Beginning Golf
 SSPE 121 Intermediate Golf
 SSPE 122 Handball
 SSPE 124 Softball \$ Ed
 SSPE 125 Soccer \$ Ed
 SSPE 130 Beginning Racquetball
 SSPE 131 Intermediate Racquetball
 SSPE 132 Advanced Racquetball
 SSPE 140 Beginning Tennis
 SSPE 141 Intermediate Tennis
 SSPE 142 Advanced Tennis
 SSPE 149 Badminton
 SSPE 150 Swimming
 SSPE 151 Intermediate Swimming
 SSPE 152 Life Saving
 SSPE 153 Advanced Life Saving
 SSPE 154 Life Guard Training
 SSPE 155 Advanced Swimming
 SSPE 156 Fitness Swimming
 SSPE 157 Aqua-Aerobics
 SSPE 158 Diving
 SSPE 159 Water Volleyball
 SSPE 160 Aerobics
 SSPE 161 Yoga
 SSPE 162 Advanced Yoga
 SSPE 163 Modern Dance
 SSPE 165 Beginning Gymnastics
 SSPE 170 Karate
 SSPE 171 Judo
 SSPE 172 Self Defense
 SSPE 180 Jogging
 SSPE 181 Skiing
 SSPE 182 Orienteering
 SSPE 183 Rock Climbing
 SSPE 184 Caving
 SSPE 185 Backpacking
 SSPE 186 Road Cycling
 SSPE 187 Conditioning and Weight Training 1
 SSPE 188 Conditioning and Weight Training 2
 SSPE 189 Horseback Riding
 SSPE 190 Beginning Scuba
 SSPE 191 Scuba—Open Water
 SSPE 197 Canoeing

 SSPE 202 **Health and Nutrition Across the Lifespan (4)** Fundamentals, practices, and appreciation of healthful living. Course addresses health, nutrition, and safety issues from early childhood through adulthood. Emphasis on promotion of healthy lifestyle choices across the lifespan.
 SSPE 203 **Human Nutrition (4)** A study of nutrients, including sources, composition, function, and metabolism in the human body. The human life cycle is considered in planning appropriate diets.

SSPE 235 - SSSM 201

SSPE 235 Orientation to Sport Industry Employment (1) Resume writing, job application, interviewing, contact follow-up, letter writing, job hunting strategies, and potential employers. *Preq. senior rank or permission; 1 lec. 1 lab*

SSPE 236 Field Experience in Sport Industry (2-6) Supervised work experience while gaining skills and knowledge of various aspects of the sports industry.

SSPE 239 Athletic Officiating—Football (3) Rules, mechanics, and procedures in officiating. Practice under actual game conditions. State certification upon successful completion of state examination. OHSSA fee for certification and books.

SSPE 240 Athletic Officiating—Basketball (3) Rules, mechanics, and procedures in officiating. Practice under actual game conditions. State certification upon successful completion of state examination. OHSSA fee for certification and books.

SSPE 241 Athletic Officiating—Baseball (3) Rules, mechanics, and procedures in officiating. Practice under actual game conditions. State certification upon successful completion of state examination. OHSSA fee for certification and books.

SSPE 242 Athletic Officiating—Volleyball (3) Rules, mechanics, and procedures in officiating. Practice under actual game conditions. State certification upon successful completion of state examination. OHSSA fee for certification and books.

SSPE 245 Introduction to Coaching (2) Introduction to high school interscholastic athletics, including history, structures, job opportunities, and contemporary programs.

SSPE 252 Youth and Sports (3) Exploration of opportunities, controversies, organization, safety, values, rules, leadership, benefits, and settings of youth sports programs.

SSPE 281 Administration of Intramural Athletics (4) Organizing and administering a program of intramural sports for all age levels. Designed especially for elementary and secondary teachers. *Preq. education and sports studies majors*

SSPE 295 Independent Study (2) Study, observation, and research in selected physical education fields. Under the direction of HPER faculty member. *Preq. permission of instructor*

SSPE 340 Coaching of Volleyball (2) Theory of coaching volleyball. Analysis of skills, strategies, methods, duties, and responsibilities.

SSPE 341 Coaching of Basketball (2) Theory of coaching basketball. Analysis of skills, strategies, methods, duties, and responsibilities.

SSPE 342 Coaching of Football (2) Theory of coaching football. Analysis of skills, strategies, methods, duties, and responsibilities.

SSPE 343 Coaching of Track (2) Theory of coaching track. Analysis of skills, strategies, methods, duties, and responsibilities.

SSPE 344 Coaching of Softball (2) Theory of coaching softball. Analysis of skills, strategies, methods, duties, and responsibilities.

SSPE 352 Sports for the Disabled (3) A presentation of sports programs and assessments that can be made available to the disabled. How to organize and administer such sporting events as competing aquatics, wheelchair basketball, archery, bowling, track and field, softball, and tennis.

SSPE 360 Drugs/Substance Abuse (4) An in-depth study of alcohol, tobacco, and other drugs and how chemical dependency on these drugs can affect individual performance and behavior.

SSPE 495 Special Topics (1-4) Study, under the supervision of instructor, of topics not otherwise available to students. *Preq. permission of instructor*

Sports Management

SSSM 201 Introduction to Sports Management (3) An introduction to the various aspects of athletics, intramural, and recreation administration.

SSSM 228 Law and Liability in Sports (4) Designed to provide information concerning the role of law in sport and physical activity for those who must deal with and manage a variety of legal concerns on a routine basis.

SSSM 366 Aquatics Management (4) A survey of the recreational aquatics environment. Hands on training in filtration systems and their general operation, an understanding of federal and state guidelines and licenser for pool operation and maintenance. Legal aspects of the aquatics area. Staffing requirements and training of aquatics personnel for indoor and outdoor facilities. *Preq. HPER 392*

SSSM 368 Introduction to Sport Law (4) Survey of the legal framework of the athletic environment. The nature of the legal system and law pertaining to sports, including tort law, contractual agreements, and civil law. *Preq. SSSM 228 and sophomore rank*

SSSM 370 Ethical Aspects of Sport (3) Identification and discussion of ethical conduct in sport as it relates to professionals in the sports industry. Discussion of appropriate conduct in handling ethical/moral situations facing the sport industry professional.

SSSM 385 Psychology of Sports (4) Offers students the opportunity to learn correct principles and applications of sport psychology. Provides a better understanding of how individuals can enhance peak performance through recent advances in sport psychology. *Preq. sophomore rank or above*

SSSM 386 Sociology of Sport (4) Designed to investigate the role physical education and sports play in the lives of individuals, societies, and countries. Considers the context of sport, focusing on the meaning of what happens in sport, where sport fits—or does not fit—into society and why. *Preq. sophomore rank or above*

SSSM 390 Sport Facility and Event Management (4) An advanced study of the facilities required for the recreational environment. An analysis of indoor and outdoor designs and utilization. An overview of the personnel process, staffing requirements, and staff development procedures. A study of activity programming for the recreational environment, including class structure, tournament procedures, proper selection of activities, and equipment needed and its care and storage. *Preq. SSSM 201 and junior rank*

SSSM 392 Sport Marketing (4) An advanced study of sports marketing strategies for the recreational environment, both internal and external. Promotional guidelines and discussion of promotional activity. Study of the budgetary process, differentiations of budget styles, and implementation of the budgetary process in both the private and public sector. *Preq. SSSM 201, BUMK 310, and junior rank*

SSSM 407 Practicum 1 (4) Practical training in general operation of recreational setting. Includes activity preparation, personnel evaluation, and budget analysis. Also includes an on campus seminar to discuss issues relating to the profession. Summative assessment includes a combination of performance checklists and evaluations by the on-site supervisor. *Preq. senior rank and faculty approval*

SSSM 408 Practicum 2 (6) Supervised field experience at an off-campus sport organization. *Preq. SSSM 407, senior rank, and faculty approval*

SSSM 450 Organization and Administration of Sport Programs and Athletics (4) Study of policies, standards, and procedures in the organization and administration of physical education and athletic programs. *Preq. SSSM 368, 390, 392, and senior rank*

Theater

THAR 100 Introduction to Theater (4) Survey of development of theater from classical to modern times, emphasizing the artists and craftspersons of the theater and their contributions to its development. *GEP \$ FA*

THAR 120 Stagecraft: Scenery and Props (3) Principles, techniques, and practice in the construction of stage props and scenery. *2 lec. 1 lab; \$ FA*

THAR 135 Practicum 1 (2) Introductory supervised studio practice in theatrical production. May be repeated up to 8 credit hours. *\$ FA*

THAR 205 - UNIV 199

THAR 205 Theater Planning and Management (3) Principles and practices of managing theatrical-producing organizations. Problems of finance, personnel, policy, program building, advertisement, publicity, and public relations.

THAR 210 Acting 1 (4) Studio acting class with emphasis on developing trust and freedom. Warm-up techniques, theater games, improvisation, acting exercises. \$ FA

THAR 211 Acting 2 (4) Studio acting class with emphasis on physical and character movement. Body awareness, dance, mask work, improvisation. \$ FA

THAR 212 Acting 3 (4) Studio acting class with emphasis on voice, scene development, and text exploration. Acting exercises, scene work, performance. \$ FA

THAR 235 Practicum 2 (2) Intermediate studio practice in theatrical production. May be repeated up to 8 credit hours. *Req. THAR 135; \$ FA*

THAR 299 Topics in Theater (1-4) A study of topics not otherwise available to students.

THAR 310 Scene Development (4) Studio in advanced acting, using various techniques to explore prepared scenes. Emphasis on ensemble work. *Req. THAR 212 or permission of instructor; \$ FA*

THAR 331 Directing 1 (4) Principles and practices of directing for stage. *Req. THAR 212*

THAR 332 Theater History (3) Development of theater and drama.

THAR 335 Advanced Practicum in Production (1-4) Advanced supervised studio practice in acting, directing, stagecraft, design, or production management work for performance of SSU theater productions. *Req. THAR 212 or 235 or permission of instructor; 1 lec. 2-6 lab; \$ FA*

THAR 420 Stage Management (4) Theory and practice of stage management as the organizational center of theatrical production. *Req. THAR 235*

THAR 431 Directing 2 (4) Advanced principles, procedures, and practices in direction are explored in a studio format. *Req. THAR 331 or permission of instructor; \$ FA*

THAR 499 Special Topics in Theater (1-4) Study of various topics not otherwise available to students. May be repeated for credit.

University

UNIV 101 Academic Development Skills (4) A course recommended for students who place into at least two developmental education courses and optional for any student on campus. Recommended for entering freshmen with a high school GPA of 2.0 or lower. Teaches study skills and test-taking techniques. Emphasis on goal setting, time management, note taking, studying and marking textbooks, taking exams, finding and using learning resources, and improving memory and concentration.

UNIV 102 Personal Development Skills (4) A course recommended for students who place into at least two developmental education courses and optional for any student on campus. Designed to help students improve their personal skills in order to become more involved members of the academic community and to have richer personal lives. Topics include attitudes, self-esteem, communication, wellness/health, anxiety and stress, creativity, problem-solving, money management/personal finance, career exploration, and orientation to university services.

UNIV 199 Topics (1-4) Individual or small group study, under the supervision of an instructor, of topics otherwise not available to students.



TRUSTEES, **STAFF**
& **FACULTY**

Board of Trustees

Davis, George L., III Chairperson
 Harcha, Howard H., Jr.
 McCoy, Jack
 McKinley, William
 Payne, A. Burton, M.D.
 Reynolds, Kay
 Teichman, Robert
 Warren, Jim
 Leo, Tracy Student

Trustee Emeritus

Ferguson, Orville R., The Late
 Hyland, Frank D., The Late

President Emeritus

Taylor, Frank C., The Late
 Veri, Clive C., Ph.D.

President and Executive Staff

Morris, Rita Rice (2003)
 President and Professor
 B.A., California State University at Long Beach
 M.A., Northern Illinois University
 Ph.D., State University of New York at Buffalo

Donohue, Stephen P. (1994)
 Vice President and General Counsel
 B.S., U.S. Military Academy
 M.B.A., Colorado State University
 J.D., Stetson University College of Law

Field, Michael (1999)
 Vice President for Academic Affairs and Provost
 B.A., SUNY at Stony Brook
 M.A., Ph.D., Cornell University

Mangus, Larry L. (1995)
 Vice President for Student Affairs
 B.S., M.Ed., Ohio University
 Ed.D., Indiana University

Murphy, Roger T. (1996)
 Vice President for Business Affairs
 B.A., M.B.A., Michigan State University

Deans

Rader, Martha C. (2002)
 Dean, Professor
 College of Professional Studies
 B.S., M.S., Ph.D., The Ohio State Univ.

Holt, Jerry G. (1990)
 Dean, Professor
 College of Arts and Sciences
 B.S., Oklahoma State University
 M.A., Ph.D., University of Oklahoma

Department Heads

Coppoletti, Sam (2001)
 Program Director, Senior Instructor
 Physical Therapist Assistant
 College of Professional Studies
 B.S., Northern Illinois University
 M.P.T., University of Iowa

Fiske, Michael B. (2001)
 Chairperson, Associate Professor
 Dept. of Mathematical Sciences
 College of Arts and Sciences
 A.B., Univ. of California at Santa Cruz
 M.A., School of Theology, Claremont
 M.A., The Ohio State University
 Ph.D., The Ohio State University

Gemmer, Gary P. (1983)
 Chairperson, Professor
 Department of Natural Sciences
 College of Arts and Sciences
 B.S., Morehead State University
 M.A.T., Miami University

Hilgarth, Carl O. (1990)
 Chairperson, Associate Professor
 Department of Industrial and Engineering Technologies
 College of Professional Studies
 B.S., The City College of New York
 M.S., University of Missouri-Rolla

Kehres, Edward C. (1996)
 Program Director, Senior Instructor
 Occupational Therapy Assistant
 College of Professional Studies
 B.S., M.S., The Ohio State University

Miller, James M. (1989)
 Chairperson, Assistant Professor
 Department of Social Sciences
 College of Arts and Sciences
 B.S., Manchester College
 Ph.D., Kent State University

Murray, Nancy L. (1992)
 Program Director, Assistant Professor
 Dental Hygiene
 College of Professional Studies
 B.S., The Ohio State University
 M.S., Marshall University

Scheurer, Timothy E. (2001)
 Chairperson, Professor
 Department of English and Humanities
 College of Arts and Sciences
 B.A., St. Mary's University
 M.A., Mankato State University
 Ph.D., Bowling Green State University

Scurlock, Debra (2000)
 Program Director, Senior Instructor
 Occupational Therapy
 College of Professional Studies
 B.S., The Ohio State University
 M.A., Ohio University

Stead, Thomas D. (1969)
 Chairperson, Associate Professor
 Department of Fine, Digital, and Performing Arts
 College of Arts and Sciences
 B.F.A., M.F.A., Ohio University

Sykes, William W. (1981)
 Chairperson, Associate Professor
 Radiologic Technology
 College of Professional Studies
 A.A.S., Central Ohio Technical College
 B.S., The Ohio State University
 M.B.A., Xavier University

Thomas, Donald L. (1986)
 Chairperson, Associate Professor
 Respiratory Therapy
 College of Professional Studies
 A.S., Kettering College of Medical Arts
 B.S., Georgia State University
 M.S., Marshall University

Thoroughman, Marla H. (1989)
 Chairperson, Associate Professor
 Medical Laboratory Science
 College of Professional Studies
 B.S., M.A., Morehead State University
 M.S., Morehead State University

Todt, David E. (1978)
 Chairperson, Professor
 Department of Teacher Education
 College of Arts and Sciences
 B.S., M.En.S., Miami University
 Ph.D., The Ohio State University

Turner, William (2000)
 Interim Program Director, Instructor
 Emergency Medical Technology
 College of Professional Studies
 A.A.S., Shawnee State University
 B.S., Columbia Southern University

Administration

Amburgey, Tim (2001)

Program Assistant, UB Math Science
and Educational Talent Search
B.S., Ohio University

Arnzen, James W. (1988)

Director, Athletics
B.S., Defiance College
M.S., University of Dayton

Ballengue, Greg (1996)

Assistant Controller
A.S., Shawnee State Community College
B.S., Miami University

Blanchard, Jerry (1999)

Project Director, 21st Century
Community Learning Centers
B.A., M.A., Morehead State University

Blanton, Lee B. (1996)

Accountant
B.S., Berea College

Boyles, Elinda C. (1988)

Director, HR/Payroll/EEO
B.S., Eastern Kentucky University
M.Ed., University Nevada Las Vegas

Bradbury, Barbara L. (1980)

Director, Pre-College Programs/Staff
Ombuds
B.S., Ohio University
M.S., University of Dayton

Burchett, Mark (1991)

Science Laboratory Assistant
Department of Natural Sciences
College of Arts and Sciences
B.S., M.S., Morehead State University

Carson, Pat L. (1984)

Director, Purchasing and Printing Svcs.

Charles, Joanne T. (1979)

Controller
B.B.A., Temple University
M.B.A., Morehead State University
C.P.A.

Charles, Thomas K. (1979)

Academic Skills Specialist/Counselor
Student Support Services
A.S., Henry Ford Community College
B.S., M.A., Western Michigan University

Chrisman, Fred (1998)

Assistant Dir./Counselor, Talent Search
B.S., Ohio University
M.Ed., Xavier University

Congos, Dennis (2003)

Director, Student Success Center
B.A., Cleveland State University
M.S.Ed., Indiana University

Crawford, Matthew (1998)

Programmer/Analyst
B.B.A., Morehead State University

Crawford, Vickie (1998)

Senior Analyst/Programmer
B.B.A., Eastern Kentucky University

Cummings, Mary Elizabeth (1988)

Librarian, Reference
B.S.Ed., Ohio University
M.S.L.S., University of Kentucky
M.A., Marshall University

Daehler, Carl (1995)

Exec. Dir., Vern Riffe Ctr. for the Arts
B.M.E., M.M.E., D.M.A., University
of Michigan

Davidson, Tom (1998)

Counselor, Talent Search
B.A., M.A., Marshall University

Donnally, April (2002)

Athletic Trainer
B.S., Shawnee State University

Duncan, William Peter (1983)

Director, Instructional Technology
B.S., Ohio University

Evans, Elaine N. (1994)

Assistant Director/Counselor
Student Support Services
B.A., Anderson University
M.S.W., The Ohio State University

Ferguson, Cindy (2001)

Director, Children's Learning Center
B.A., Mount Union College
M.Ed., Kent State University

Gerlach, Leigh A. (1996)

Internet Manager
A.A.B., Shawnee State University

Gregory, Stephen (1989)

Director, Career Services
B.B.A., Ohio University
M.S., University of Dayton

Grundler, Mark W. (1992)

Assoc. Dir., Administrative Computing
A.S., Iowa Technical Institute
B.S., University of Iowa

Haffner, Ruthie J. (1991)

Coordinator, SOACDF

Hamilton, Jeff (2002)

Head Coach, Athletics
B.A., College of Wooster
M.S., Ohio University

Hannah, William A. (1987)

Associate Dir., Instructional Technology
B.S., M.A., Ohio University

Hapney, Terry L., Jr. (1998)

Director of Communications and
Assistant to the President
B.A., University of Kentucky
M.A.J., Marshall University

Harr, Rebecca (2000)

Assistant Director, Upward Bound
B.S., Shawnee State University

Hedrick, Amanda (2000)

Preschool Teacher, Children's Learning
Center
B.S., The Ohio State University

Horne, Megan, (1998)

Program Manager, School-to-Work and
University Outreach Services
B.A., Berea College

Howard, Richard R. (1971)

Counselor, Talent Search
B.S., The Ohio State University
M.A., Eastern Kentucky University

Hughes, Michael J. (1990)

Director, Counseling and Psych. Services
B.S., M.S., University of Scranton
Ed.D., West Virginia University

Kotcamp, Lloyd (Butch) (1990)

Director, Facilities

Lata, Kimberly A. (1998)

Institutional Research Analyst
B.A., M.A., Edinboro University of
Pennsylvania

Lawson, George (2001)

Project Director, Ohio South Tech Prep
Consortium
B.S.Ed., Ohio University
M.Ed., Xavier University

Madden, Jaime M. (1995)

Project Manager, UIS
B.S., University of Dayton

Madden, Paul M. (1992)

Director, Preprofessional Services
College of Arts and Sciences
B.S.Ed., University of Dayton
M.Ed., Ohio University

Malone, Mary Ann (1993)

Project Dir., Student Support Services
B.S., Ohio Dominican College
M.A., Ohio University

Maroudis, Mary (2001)

Manager, Education for Industry
B.S., The Ohio State University
M.Ed., University of Rio Grande

Matthews, Eustace P. (1990)

Coord., Multicultural Student Services
A.A., Shawnee State University
B.A., M.Ed., Ohio University

McCall, Ryan (1999)

Director, UB Math Science and
Educational Talent Search
B.S., Shawnee State University
M.S., Morehead State University

McGraw, Judith E. (1990)

Manager, Human Resources

McKenzie, DeAnn (2002)

Accountant
B.S., Shawnee State University

McKenzie, Teresa (1998)

Outreach Coordinator, EOC
B.S., Western Carolina University

Meeker, Judy (1991)

Program Mgr., Ohio South Tech Prep
Consortium and Univ. Outreach Svcs.
A.S., B.S., Shawnee State University

Merb, Rick (1994)

Associate Director, Admission
B.S., M.Ed., Bowling Green State Univ.

Midkiff, Stephen J. (1975)

Registrar
B.A., University of Kentucky
M.Ed., Harvard University
Ph.D., Ohio University

Midkiff, Tess D. (1975)

Director, Library
B.A., University of Kentucky
M.L.S., Simmons College

Minnix, David (2001)

County Coordinator (Pike), 21st
Century Community Learning Centers
B.S., M.A., Xavier University

Moore, Mark A. (1987)

Associate Registrar
A.A.S., Shawnee State Community Col.
B.A., Ohio University

Moore, Patricia J. (1971)

Dir., Financial Aid/Veteran's Affairs
A.S., Shawnee State University
B.B.A., Ohio University
M.Ed., University of Dayton

Moore, Virginia C. (1984)

Director, University Outreach Services
B.S.Ed., M.B.A., Ohio University

Mullins, Cathy (1990)

Academic Grants Officer/Assistant to
the Provost
B.S., M.B.A., Ohio University

Musick, Larry (2002)

Manager, Contract Training, Education
for Industry
B.A., Marshall University

NG, Man Tjun (2000)

Accountant
B.S., University of Kentucky
M.B.A., Eastern Kentucky University

Osborn, H. Garry

Director, GEAR-UP
B.S. Ohio University
M.A., Marshall University

Phillips, Hetty (1999)

Head Teacher, Children's Learning Ctr.
B.A., Ohio University
M.Ed., Rio Grande University

Pinson, Michael (1990)

Systems/Network Manager
A.A.S., Shawnee State University

Powell, Sherri (1989)

HEI Coordinator
A.A.B., Shawnee State Community Col.
B.B.A., Ohio University
M.S., University of Dayton

Preston, Deanna (2001)

Admission Officer
B.A., Shawnee State University

Rader, Lisa (2002)

Accountant
B.S., Shawnee State University

Rase, Lois (1993)

Coordinator, BEARS Program
B.S., M.S., Ohio University

Redoutey, Teresa (1994)

Coordinator, Academic Support
B.S., Ohio University
M.S.Ed., University of Dayton

Rockwell, C. William (1997)

Coord., Housing and Residence Life
B.B.A., University of Cincinnati

Rodgers, David R. (2000)

Librarian, Technical Services
B.A., Hendrix College
M.L.S., Indiana University
M.Div., Vanderbilt University

Russell, Mark (2000)

Programmer/Analyst
B.S., Morehead State University

Salyer, Gary (2000)

County Coord. (Scioto), 21st Century
Community Learning Centers
B.A., M.S., Marshall University

Salyers-Stoner, Connie E. (1988)

Associate Dir., Library/Public Services
B.S., Wright State University
M.L.S., George Peabody College for
Teachers

Saul, Brian (2000)

Admission Officer
B.A., Shawnee State University

Schlosser, Leo A. (1995)

Tech. Dir., Vern Riffe Ctr. for the Arts
B.A., Northern Kentucky State College
M.F.A., Ohio University

Seals, David D. (2000)

County Coordinator (Lawrence), 21st
Century Community Learning Ctrs.
B.A., M.A., Morehead State University

Shimfessel, Lois (1999)

Preschool Teacher, Children's Learning
Center
B.S.Ed., Union College

Shoemaker, Jared (1999)

Assistant Director, Athletics/Sports
Information Director
B.A., M.S., University of Kentucky

Short, Ann Marie (1997)

Librarian, Circulation
B.A., Mary Washington College of the
University of Virginia
M.S.L.S., University of Tennessee

Stephens, Danny R. (2000)

Coordinator, GEAR-UP
B.S., Shawnee State University

Stewart, Janet (2001)

Systems Librarian
B.A., Stephen F. Austin State University
M.L.S., Kent State University

Taylor, Dale F. (1988)

Coordinator, Student Academic
Assessment Services
A.I.S., Shawnee State Community Col.
B.G.S., Ohio University
M.H.E., Morehead State University
L.S.W., State of Ohio

Tomlin, Mary A. (1975)

Assistant Director, Financial Aid
A.A.B., Shawnee State University

Trusz, Robert J. (2000)

Director, Admission
B.S., M.S.Ed., Purdue University

VanDeusen, Joseph (2003)

Assistant Director, Facilities
A.S., Shawnee State University
B.S., M.B.A., University of Findlay

Warman, Randall K. (1992)

Dir., Student Activities and Auxiliaries
B.S.C., Ohio University

Warner, Charles (2000)

Director, University Information Services
B.A., M.B.A., The Ohio State Univ.

Warsaw, Susan S. (1983)

Executive Director, Development
B.A., The Ohio State University

Watson, Deborah E. (1991)

Coordinator, Academic Advising
B.A., M.A., Morehead State University

Weaver, Tiffany (2002)

Coordinator, Student Activities
B.A., Shawnee State University

Webb, Regina (1991)

OACHE Program Specialist
A.A.B., Shawnee State University

Weber, Debbie (1997)

Coord., Clinical and Field Experiences
B.A., Shawnee State University

White, Dan (1995)

User Support Manager
B.S., Shawnee State University

White, Wayne (1993)

Exec. Director, Ohio Appalachian
Center for Higher Education
M.A.Ed.Admn., Ohio University

Yager, Rhonda L. (1997)

Systems Manager/Assistant Director,
Financial Aid
A.A.B., B.S., Shawnee State University

Yarnell, Mark A. (1997)

Network Systems Engineer

Faculty**Basham, Julia L. (1982)**

Professor, Biology
College of Arts and Sciences
B.A., B.S., M.S., Univ. of Cincinnati
M.S., Marshall University

Bauer, Jeffrey A. (1987)

Professor, Geology
College of Arts and Sciences
B.S., Bowling Green State University
M.S., Ph.D., The Ohio State University

Blau, Phil (2000)

Associate Prof., Mathematical Sciences
College of Arts and Sciences
B.A., SUNY Binghamton
Ph.D., Univ. of Massachusetts, Amherst

Bostick, Trudy (1977)

Sr. Instructor, Mathematical Sciences
College of Arts and Sciences
B.S., Ohio University
M.S., Wright State University

Bullock, Barbara (Beth) (1998)

Senior Instructor, Nursing
College of Professional Studies
B.S.N., Indiana University
M.S.N., University of Phoenix

Burke, Robbie A. (1974)

Professor, Business Management
College of Professional Studies
B.A., West Virginia Wesleyan
M.S., M.B.A., Marshall University

Burns, Eugene H., Jr. (1999)

Associate Professor, Biology
College of Arts and Sciences
B.S., Ph.D., University of Tennessee

Byrne, Francis X. (1987)

Professor, English/Linguistics
College of Arts and Sciences
B.A., M.A., Colorado State University
M.A., Ph.D., University of Arizona

Canter, Mary Ann (1987)

Clinical Coordinator, Assoc. Professor
Respiratory Therapy
College of Professional Studies
B.S.A.S., Youngstown State University
M.H.S.A., Ohio University

Chaffin, Cathy M. (1980)

Professor, Office Administration
College of Professional Studies
B.S., Berea College
M.B.E., Morehead State University

Chrisman, Elizabeth A. (1980)

Professor, Dental Hygiene
College of Professional Studies
A.A.S., Scioto Technical College
B.S., M.Ed., Ohio University

Coll, Julia R. (1987)

Professor, Spanish
College of Arts and Sciences
Licenciada en Educacion,
Universidad de Oriente
M.A., M.Ed., Ph.D., Univ. of Arizona

Conn, Barbara J. (1997)

Associate Professor, Nursing
College of Professional Studies
B.S., The College of St. Teresa
M.S., The Ohio State University

Cram, Matthew S. (1999)

Instructor, Art
College of Arts and Sciences
B.F.A., Morehead State University
M.F.A., Vermont College of the Union
Institute

Crummie, Karen S. (1993)

Associate Professor, Legal Assisting
College of Professional Studies
B.A., Mount Vernon Nazarene College
J.D., Valparaiso University School of Law

Darbro, Douglas G. (1998)

Assistant Prof., Mathematical Sciences
College of Arts and Sciences
B.S., Morehead State University
M.A., Ph.D., University of Kentucky

Day, D. James (1987)

Professor, Business Management
College of Professional Studies
B.S., West Liberty State College
M.B.A., Eastern New Mexico University
Ph.D., The University of Iowa

Deal, D. Robert (1988)

Professor, Biology/Research Officer
College of Arts and Sciences
B.A., Capital University
M.A., Miami University
Ph.D., Cornell University

Denning, Leeann (2001)

Senior Instructor, Nursing
M.S.N., University of Phoenix

Dillard, Mary L. (1989)

Professor, English
College of Arts and Sciences
B.S.Ed., M.S.T., Georgia Southern Col.
Ed.D., University of Tennessee

Dixon, W. Dean (2001)

Instructor, Emergency Medical Tech.
College of Professional Studies
A.A.S., B.I.S., Shawnee State University

Doster, Steven J. (1989)

Professor, Accounting
College of Professional Studies
B.S., The Col. of William and Mary
M.B.P.A., Southeastern University
D.B.A., Argosy University
C.P.A., C.M.A.

Duncan, Barbara S. (1980)

Professor, Dental Hygiene
College of Professional Studies
A.A.S., Scioto Technical College
B.S., M.Ed., Ohio University

Dzik, Anthony J. (1988)

Associate Professor, Geography
College of Arts and Sciences
B.A., Roosevelt University
M.A., University of Toledo
Ph.D., Northwestern University

Essman, Larry C. (1975)

Professor, Accounting
College of Professional Studies
B.A., M.B.A., Ohio University
C.P.A.

Estep, Larry M. (1972)

Associate Prof., Business Management
College of Professional Studies
B.B.A., Ohio University
M.S., M.B.A., Marshall University

Ferguson, Orville R. II (1989)

Professor, Mathematics
Developmental Education
College of Arts and Sciences
B.S., West Virginia State University
M.S. Ed.Ad., Xavier University

Finlow, David E. (1999)

Assoc. Prof., Plastics Engineering Tech.
College of Professional Studies
B.S., University of Liverpool
M.S., Univ. of Newcastle-Upon-Tyne
Ph.D., University of Rhode Island

Flavin, James P. (1983)

Professor, English
College of Arts and Sciences
B.A., M.A., Ft. Hays Kansas State Univ.
Ph.D., Miami University

Forrey, Robert J. (1989)

Professor, English
College of Arts and Sciences
B.A./M.A., Wesleyan University
Ph.D., Yale University

Gallaher, Janna B. (1991)

Associate Prof., Computer Eng. Tech.
College of Professional Studies
B.S., St. Louis University
M.S., University of Missouri
Ph.D., Ohio University
P.E.

Gampp, Anna R. (1971)

Associate Professor, Nursing
College of Professional Studies
B.S.N., The Ohio State University
M.Ed., Ohio University

Goetting, Melvin J. (1987)

Assistant Prof., Business Info. Systems
College of Professional Studies
B.B.A., M.B.A., University of Toledo

Hadjiyannis, Stylianos I. (1989)

Professor, Political Science
College of Arts and Sciences
B.A., California State University
M.A., Ph.D., University of California

Hagen-Smith, Robin G. (1984)

Senior Instructor, Physical Education
College of Arts and Sciences
B.S., Rio Grande College
M.Ed., Xavier University

Hamilton, Virginia M. (1987)

Professor, Mathematical Sciences
College of Arts and Sciences
B.A., M.S., Ball State University

Hanlon, William J. (1988)

Asst. Prof., Business Info. Systems
College of Professional Studies
B.S., University of Pittsburgh
M.B.A., Cleveland State University
C.D.P.

Harris-Fain, Darren (1995)

Associate Professor, English
College of Arts and Sciences
A.B., Ohio University
M.A., Ph.D., Kent State University

Herrmann, Sibylle R. (1969)

Assoc. Professor, Biological Sciences
College of Arts and Sciences
B.S., Ohio University
M.S., University of Michigan

Houser, Jean P. (1997)

Associate Prof., Computer Science
College of Professional Studies
B.S., M.A., Morehead State University
M.S., University of Evansville

Huang, Xiaodan (1993)

Professor, Education
College of Arts and Sciences
B.A., Nanchang Teachers College
M.Ed., St. Bonaventure University
Ph.D., Cornell University

Ison, Steven A. (1996)

Assistant Prof., Environmental Eng. Tech.
College of Professional Studies
B.S.I.E., Texas Tech University
M.S.I.E., Purdue University
M.S.M., Troy State University

Jenkins, Loretta (1982)

Assistant Professor, Accounting
College of Professional Studies
A.A.B., Shawnee State Community Col.
B.B.A., M.Ed., Ohio University

Johnson, Janice (1998)

Sr. Instructor, Business Info. Systems
College of Professional Studies
B.B.A., Shawnee State University
M.B.A., Morehead State University

Kacir, Christopher (2002)

Assistant Professor, Psychology
College of Arts and Sciences
B.A., M.S., Ph.D., Ohio University

Kelley, John L. (1969)

Professor, History/Political Science
College of Arts and Sciences
B.A., Marian College
M.A., Indiana University
Ph.D., Ohio University

Kiser, Shannon (1972)

Associate Professor, English
College of Arts and Sciences
B.A., Morehead State University
M.A., University of Kentucky

Kosan, Julius Ted (1990)

Assistant Professor, Computer Eng. Tech.
College of Professional Studies
B.S., M.S., Bowling Green State Univ.

Kunkle, Barbara K. (1981)

Associate Professor, English
College of Arts and Sciences
B.A., University of Kentucky
M.A., Marshall University
Ph.D., Bowling Green State University

Lawson, Shannon (2001)

Senior Instructor, English
College of Arts and Sciences
B.A., University of the Witwatersand
M.A., Marshall University

Leedom, Wm. Patric (1993)

Associate Professor, Education
College of Arts and Sciences
B.A., San Francisco State University
M.Ed., Xavier University
Ed.D., University of Cincinnati

Leighfield, Kenneth (1998)

Associate Professor, Education
College of Arts and Sciences
B.A., McMaster University
M.Ed., Ed.D., University of Virginia

Li, Jinlu (1989)

Professor, Mathematical Sciences
College of Arts and Sciences
B.S., Beijing University
Ph.D., Wayne State University

Linde, Mary Kathryn (1997)
Professor, Medical Laboratory Science
College of Professional Studies
B.S., Northwestern State University
M.S., Ph.D., The Ohio State University

Locke, Kathryn G. (1999)
Associate Professor, Education
College of Arts and Sciences
B.S.Ed., M.A.Ed., Ed.D., Univ. of Akron
Administrative Cert., Kent State Univ.

Lonney, Larry W. (1989)
Assistant Professor, Physics
College of Arts and Sciences
B.S., Illinois State University
M.S., Purdue University
Ph.D., Washington State University

Lorentz, John H. (1990)
Director, Center for International
Programs/Professor, History
College of Arts and Sciences
B.A., Miami University
M.A., Harvard University
Ph.D., Princeton University

Lyons, Gregory A. (2000)
Assistant Professor, Art
College of Arts and Sciences
B.F.A., Shawnee State University
M.F.A., Memphis College of Art

Massie, Gayle D. (1982)
Associate Professor, Nursing
College of Professional Studies
B.S.N., Spalding University
M.S.N., University of Tennessee

Mauldin, Robert (1994)
Director, General Education Program/
Professor, Chemistry
College of Arts and Sciences
B.S., University of Tennessee at Martin
Ph.D., University of Tennessee

McCoy, Jerry M. (2001)
Senior Instructor, Health Management
College of Professional Studies
B.S., M.S., Ohio University

Meriwether, Nicholas K. (1996)
Associate Professor, Philosophy
College of Arts and Sciences
B.A., Hendrix College
M.A., Trinity Evangelical Div. School
Ph.D., Purdue University

Miller, Larry M. (2001)
Assistant Professor, Plastics Eng. Tech.
College of Professional Studies
B.S., The Ohio State University
M.S., Ph.D., Ohio University

Milliken, Roberta L. (1996)
Associate Professor, English
College of Arts and Sciences
B.A., M.A., Ohio University
Ph.D., University of Toledo

Miner, Edward C. (1983)
Professor, Sociology and Psychology
College of Arts and Sciences
B.A., Youngstown State University
M.A., Kent State University
Ph.D., Kent State University and
University of Akron

Mirabello, Mark L. (1987)
Associate Professor, History
College of Arts and Sciences
B.A., University of Toledo
M.A., University of Virginia
Ph.D., University of Glasgow (Scotland)

Mize, Adair L. (2002)
Senior Instructor, Nursing
College of Professional Studies
B.S.N., M.S.N., Bellarmine University

Moore, Dan M. (1988)
Professor, Business Management
College of Professional Studies
B.S., University of Virginia
M.B.A., D.B.A., Georgia State University

Napper, Andrew M. (2002)
Assistant Professor, Chemistry
College of Arts and Sciences
B.S., University College of Wales,
Swansea University (UK)
Ph.D., University of Pittsburgh

Nickel, Linda K. (1978)
Professor, Dental Hygiene
College of Professional Studies
A.A.S., Scioto Technical College
B.S., M.Ed., Ohio University

O'Connor, Christopher (1992)
Associate Prof., Mathematical Sciences
College of Arts and Sciences
B.A., Univ. of California at Santa Cruz
M.S., San Jose State University
Ph.D., University of Oregon

Oliver, Scott D. (1976)
Professor, Biological Sciences
College of Arts and Sciences
D.D.S., M.S., The Ohio State University

Pambookian, Hagop S. (1987)
Professor, Psychology
College of Arts and Sciences
B.A., American University of Beirut
M.A., Columbia University
Ph.D., University of Michigan

Penn, William H. (1977)
Associate Professor, Computer
Aided Drafting and Design
College of Professional Studies
B.S.A.S., Miami University
M.Ed., Ohio University

Poirot, Clifford S., Jr. (1999)
Director, Honors Program/Assistant
Associate Professor, Economics
College of Arts and Sciences
B.A. Guilford College
Ph.D., University of Utah

Pope, Priscilla G. (2002)
Sr. Instructor, Physical Therapist Asst.
College of Professional Studies
B.S., Pennsylvania State University
M.P.H., University of Hawaii

Powell, Michael (2002)
Senior Instructor, English
College of Arts and Sciences
B.A., Shawnee State University
M.A., Ohio University

Priode, Carl E. (1985)
Associate Professor, Electromechanical
Engineering Technology
College of Professional Studies
B.S.E.T., Franklin University
M.S., East Tennessee State University

Raber, Christine (1998)
Assistant Prof., Occupational Therapy
College of Professional Studies
B.S., M.S., The Ohio State University

Rader, Steven D. (1996)
Associate Professor, Sports Studies
College of Arts and Sciences
B.S.P.E., M.S.A., Ph.D., Ohio University

Raiser, Lane C. (1989)
Associate Professor, Art
College of Arts and Sciences
B.A., Kutztown State College
M.F.A., Brooklyn College

Renfroe, Brenda S. (1991)
Assistant Professor, Radiologic Tech.
College of Professional Studies
A.A.S., B.U.S., Morehead State Univ.
M.S., Midwestern State University

Roach, Rose B. (2002)
Assistant Professor, Nursing
College of Professional Studies
B.S.N., University of Akron
M.S., San Jose University

Robson, Vivian (1995)
Associate Professor, Theatre
College of Arts and Sciences
B.A., University of Massachusetts Boston
M.F.A., Univ. of Wisconsin, Madison

Ruby, Jerry L. (1988)

Professor, Finance
College of Professional Studies
B.B.A., Ohio University
M.B.A., Morehead State University

Scheurer, Pam (2002)

Assistant Professor, Education
College of Arts and Sciences
B.S., College of Saint Teresa
M.A., Ph.D., The Ohio State University

Schwing, Carl M. (1998)

Assistant Professor, Environmental
Engineering Technology
College of Professional Studies
B.S., Xavier University
M.S., Washington University
P.E.

Scott, Sharon M. (1978)

Professor, Nursing
College of Professional Studies
A.D.N., B.S.N., M.Ed., Ohio University
M.S.N., Bellarmine College

Shipley, Gay Lynn (1998)

Associate Professor, Education
College of Arts and Sciences
B.A., Wilmington College
M.S., Ph.D., University of Dayton

Simon, Kathleen M. (1971)

Professor, English
College of Arts and Sciences
B.A., M.A., Eastern Kentucky University
Ph.D., Ohio University

Sissel, Melinda D. (1988)

Instructor, Occupational Therapy
College of Professional Studies
A.A.S., Shawnee State Community Col.
B.I.S., Shawnee State University

Smith, Lyle B. (1975)

Coordinator, Assistant Professor
Plastics Engineering Technology
College of Professional Studies
B.S., Ohio University

Spradlin, Patricia Conley (2000)

Assistant Professor, English
College of Arts and Sciences
B.A., M.A., Marshall University

Strunk, Priscilla A. (Sunny) (1984)

Instructor, Respiratory Therapy
College of Professional Studies
A.A.S., B.I.S., Shawnee State University

Taylor, Krista (1999)

Associate Prof., Mathematical Sciences
B.S., University of Oregon
M.S., Ph.D., Univ. of Nebraska, Lincoln

Thiel, Becky A. (1981)

Associate Professor, Nursing
College of Professional Studies
B.S.N., The Ohio State University
M.S.N., University of Tennessee

Trampe, George M. (1977)

Associate Professor, Chemistry
College of Arts and Sciences
B.S., University of Illinois
Ph.D., Purdue University

Valentine, Eugene J. (1990)

Professor, Philosophy
College of Arts and Sciences
A.B., Harvard University
M.A., Ph.D., Michigan State University

Vestich, Eli T. (1997)

Assistant Professor, Computer Aided
Drafting and Design
College of Professional Studies
B.A., Indiana University of Pennsylvania
M.Ed., Bowling Green State University

Walker, Marsha L. (1987)

Assoc. Prof., Office Administration
College of Professional Studies
B.S., M.A., The Ohio State University

Ward, James Anthony (2001)

Senior Instructor, Sports Studies/
Athletic Training
College of Arts and Sciences
B.A., M.S., Marshall University

Warfield, Kenneth W. (1983)

Assistant Prof., Electromech. Eng. Tech.
College of Professional Studies
B.G.S., Ohio University

Whitaker, John J. (2003)

Assistant Prof., Mathematical Sciences
College of Arts and Sciences
B.S., Birmingham-Southern College
Ph.D., Louisiana State University

Yost, Carlson W. (1987)

Associate Professor, English
College of Arts and Sciences
B.S., Cornell University
B.A., Utica College of Syracuse Univ.
M.A., Ph.D., Texas A & M University

Yost, Paul (1996)

Assistant Professor, Computer Eng. Tech.
College of Professional Studies
B.S., Shawnee State University
M.S., University of Cincinnati

Professor Emeritus

Hodgden, Betty L., The Late
Wilson, Robert L., Ph.D.

Index

A

- Academic Advising, 61, 62
 Academic Assessment, 38
 Academic Calendar, 10-13
 Academic Integrity, 37
 Academic Policies, 36-42
 Academic Probation, 40
 Academic Programs, 53, 54
 Academic Suspension/Dismissal, 40
 Accelerated Bachelor's Degree Programs, 60
 Accounting Technology, Associate of Applied Business in, 137, 138
 Accreditations and Approvals
 associate degree nursing, 9, 151
 dental hygiene, 8, 152
 emergency medical technology, 9, 154
 health management, 9, 134, 135
 medical laboratory technology, 8, 156
 nursing, 9, 145
 occupational therapy assistant (associate degree), 8, 158
 occupational therapy (bachelor's degree), 8, 147
 physical therapist, 8, 160
 radiologic technology, 8, 161
 respiratory therapy, 8, 163
 teacher education, 8
 two-year business programs, 8
 university, of the, 8, 9
 ACT/SAT, 15, 21, 26, 177
 Adding a Class, 41
 Administration, 279-281
 Administrative Hold, 37, 38
 Admission Policies, 14, 23, 42
 ACT/SAT, 15, 21
 advanced placement, 16
 applicants with GED, 15, 16
 bachelor of individualized studies, 61, 62, 128, 129
 degree-seeking high school graduates, 15
 freshman studies, 16
 health science students, 15
 high school students, 21-23
 honors program, 42
 international students, 20, 21
 non-degree students, 21, 23
 senior citizens, 21
 sports studies, 122, 123
 transfer students, 17-20
 transient students, 21
 undeclared major/undecided students, 16
 Adolescent to Young Adult Licensure, 68, 69, 82, 83, 91, 92, 101-103, 114-119
 earth, life, or physical science, 90, 91, 117, 118
 integrated language arts, 68, 69, 114, 115
 integrated mathematics, 82, 83, 115
 integrated science, 91, 92, 118, 119
 integrated social studies, 101-103, 115-117
 Advanced Placement, 16
 for LPNs, 152
 radiologic technology, 161, 162
 respiratory therapy, 162-164
 Associate of Arts, 62, 63
 Associate Degree Nursing, 150-152
 accreditation, 151
 admission requirements, 148-150
 guidelines for appealing dismissal, 145
 program requirements, 151
 Associate of Individualized Studies, 64, 129
 Associate of Science, 63
 Athletic Training, Bachelor of Science in Sports Studies, 122, 123
 Athletics, Intercollegiate, 47
 Athletics, Intramural, 47
 ATM, 50
 Attendance, 40
 Audit, 40
 Awarding of Credit, 37
- Advanced Technology Center, 6
 Advising, 40, 61
 Affiliated Organizations, 183, 184
 Alumni Association, 52
 American Mideast Conference (AMC), 6, 47
 American or British Literature Minor, 69
 Appeal Procedure, 18, 20, 35, 39, 145
 dismissal from health science programs, 145
 financial aid, 35
 grades, 39
 transfer credit, 18, 20
 Applicants with GED, 16
 Application, 15-23, 31, 122
 bachelor of science, sports studies, 122
 financial aid, 31
 for admission, 15-23
 high school students, 22, 23
 Art Education, Bachelor of Fine Arts in, 74-76
 Articulation Agreements, 16
 Articulation and Transfer, State Policy, 17, 18
 Arts and Sciences, College of, 58-125
 academic advising, 61
 accelerated bachelor's degree programs, 60
 associate of arts, 62, 63
 associate of science, 63
 associate of individualized studies, 64
 baccalaureate degree requirements, 61
 bachelor of individualized studies, 61, 62
 course scheduling and offerings, 64
 double major guidelines, 61
 English and humanities, department of, 65-71
 faculty, 60
 fine, digital, and performing arts, department of, 72-78
 mathematical sciences, department of, 79-85
 minors, 62
 natural sciences, department of, 86-95
 pass/no-credit policy, 64
 preparation for teacher licensure, 64
 programs offered, 59, 60
 selecting and declaring a degree major, 60, 61
 social sciences, department of, 96-106
 teacher education, department of, 107-125
 telephone number, 4, 59
 Assessment, 38
 Associate of Applied Business, 137-142
 accounting, 137, 138
 business information systems, 138, 139
 business management, 139, 140
 legal assisting, 140, 141
 office administration technology, 141, 142
 Associate of Applied Science, 150-164, 170-173
 computer aided design, 170, 171
 dental hygiene, 152, 153
 early childhood development, 121
 electromechanical engineering technology, 171, 172
 emergency medical technology, 154-156
 medical laboratory technology, 156, 157
 nursing, 150-152
 occupational therapy assistant, 158, 159
 physical therapist assistant, 159-161
 plastics engineering technology, 172, 173
 radiologic technology, 161, 162
 respiratory therapy, 162-164
 Associate of Arts, 62, 63
 Associate Degree Nursing, 150-152
 accreditation, 151
 admission requirements, 148-150
 guidelines for appealing dismissal, 145
 program requirements, 151
 Associate of Individualized Studies, 64, 129
 Associate of Science, 63
 Athletic Training, Bachelor of Science in Sports Studies, 122, 123
 Athletics, Intercollegiate, 47
 Athletics, Intramural, 47
 ATM, 50
 Attendance, 40
 Audit, 40
 Awarding of Credit, 37
- ## B
- Baccalaureate Degree Requirements, 61
 Bachelor of Arts, 66-69, 97-104
 English/humanities, 67-69
 with integrated language arts with adolescent to young adult licensure, 68, 69
 history, 97, 98
 international relations, 98, 99
 psychology, 99, 100
 social science, 100, 101
 with integrated social studies with adolescent to young adult licensure, 101-103
 social science, legal assisting (2 + 2), 101
 sociology, 103, 104
 Bachelor of Fine Arts, 73-78
 art education, 74-76
 ceramics, drawing, painting, and photography/imaging, 74-76
 studio arts, 76, 77
 visualist digital design and interactive media, 77, 78
 Bachelor of Individualized Studies, 61, 62, 128, 129
 Bachelor of Science, 80-84, 88-93, 111-114, 122-124, 131-137, 145-148, 167-170
 biology, 88
 business administration
 accounting, 132, 133
 general business, 134
 health management, 134, 135
 legal assisting (2 + 2), 136
 management information systems, 136, 137
 chemistry, 88, 89
 computer engineering technology, 167, 168
 education, licensure in early childhood, 111, 112
 education, licensure in early childhood intervention specialist, 112
 education, licensure in middle childhood, 112, 113
 education, licensure in multiage intervention specialist, 113, 114

environmental engineering technology, 168-170
 mathematical sciences, 80-82
 integrated mathematics with adolescent to young adult licensure, 82, 83
 natural science, 89-93
 earth, life, or physical science with adolescent to young adult licensure, 90, 91
 integrated science with adolescent to young adult licensure, 91, 92
 mathematics, 83
 mathematics and science with middle childhood licensure, 83, 84, 92, 93
 nursing (RN-BSN), 145, 146
 occupational therapy, 146-148
 plastics engineering technology, 170
 sports studies, athletic training, 122, 123
 sports studies, fitness development, 123, 124
 sports studies, sports management, 124
 Bad Check Policy, 30
 Basic Adult Skills in a College Setting (BASICS), 177
 BEAR CUBS Program, 177
 Biology, Bachelor of Science in, 88
 Biology Minor, 93
 Board of Trustees, 277
 Bookstore, 47
 Bureau of Worker's Compensation, 180
 Business Administration, Bachelor of Science in, 131-137
 accounting, 132-134
 general business, 134
 health management, 134, 135
 legal assisting (2 + 2), 136
 management information systems, 136, 137
 Business Administration, Department of, 130-142
 associate of applied business, 137-142
 accounting technology, 137, 138
 business information systems, 138, 139
 business management technology 139, 140
 legal assisting technology, 140, 141
 office administration technology, 141, 142
 bachelor of science, business administration, 131-137
 accounting, 132-134
 general business, 134
 health management, 134, 135
 legal assisting (2 + 2), 136
 management information systems, 136, 137
 programs offered, 131
 minor, business administration, 142
 minor, health management, 142
 special notes, 131, 132
 telephone number, 4, 131
 Business Information Systems, Associate of Applied Business in, 138, 139
 Business Management Technology, Associate of Applied Business in, 139, 140

C

CADD Certificate Program, 173
 CADD Sequence, 171
 Calendar, 10-13
 Campus Tours, 23
 Campus View Rates (room and board), 31
 Career Counseling, 177
 Career Services, 48
 Career Exploration for Women, 182
 Carriage House Rates (room and board), 31
 Catalog Rights, 37
 Cedar House Rates (room and board), 31
 Center for International Programs and Activities, 6, 43, 44
 Ceramics, Drawing, Painting, and Photography/Imaging, Bachelor of Fine Arts in, 74-76
 Certificates, 93, 125, 173
 computer aided drafting and design, 173
 deaf studies, 125
 environmental science, 93
 plastics engineering technology, 173
 web engineering technology, 173
 Changing Grades, 39
 Chemistry, Bachelor of Science in, 88, 89
 Chemistry Minor, 93
 Children at the University, 41
 Children's Learning Center, 6, 47, 48, 109
 Class Ranking, 37
 Class Scheduling, 144
 Clark Memorial Library, 6, 44, 45
 Clark Planetarium, 6
 College Level Examination Program (CLEP), 39
 College Work Study, 31, 33
 Communication with the University, 4
 Communications System Fee, 31
 Community Education Program, 180
 Composition/Foreign Language Labs, 66
 Computer Aided Design, Associate of Applied Science in, 170, 171
 CADD sequence, 171
 Computer Aided Design, Minor in, 174
 Computer Aided Drafting and Design Certificate in, 173
 Computer Engineering Technology, Bachelor of Science in, 167, 168
 Computer Enrichment Training, 180
 Computer Labs, 44
 Contract Training, 181
 Counseling, 48, 49
 Counseling and Psychological Services, 48
 Course Descriptions, 185-276
 Course Scheduling and Offerings, 64
 Credit by Arrangement, 29, 40
 Credit by Examination, 30, 38, 39
 Credit for Military Educational Experiences, 39

D

Deaf Studies, 125
 Deans, 278
 Dean's List, 38
 Declaring a Major, 60, 61

Degrees Offered, 54
 Dental Hygiene, Associate of Applied Science in, 152, 153
 academic requirements, 153
 accreditation, 152
 admission requirements, 148-150
 guidelines for appealing dismissal, 145
 job opportunities, 152, 153
 program goals, 152
 Department Heads, 278
 Developmental Education, 44
 Dining, 50, 51
 Disability Services, 49
 Dismissal, 40
 District Science Day, 180
 Double Major Guidelines, 61
 Drawing, 74, 76
 Dropping a Class, 41

E

Early Childhood Development, Associate of Applied Science in, 121
 Early Childhood Licensure, 111, 112
 Early Childhood Intervention Specialist Licensure, 112
 Earth, Life, or Physical Science with Adolescent to Young Adult Licensure, 90, 91, 117, 118
 Economics Minor, 104
 Education, Bachelor of Science in, 111-114
 licensure in early childhood, 111, 112
 licensure in early childhood intervention specialist, 112
 licensure in middle childhood, 112, 113
 licensure in multiage intervention specialist, 113, 114
 Education Field Fee, 30
 Educational Opportunity Center, 184
 Educational Testing Service, 16
 Elderhostel, 180
 Electromechanical Engineering Technology, Associate of Applied Science in, 171, 172
 E-mail address, 4
 Emergency Loan Fund, 33
 Emergency Medical Technology, 154-156
 academic requirements, 154, 155
 accreditation, 154
 admission requirements, 148-150
 certification, 154
 employment opportunities, 154
 entrance requirements, 155
 guidelines for appealing dismissal, 145
 Employment, Student, 33
 English/Humanities, Bachelor of Arts in, 67-69
 English and Humanities, Department of, 65-71
 academic advising, 61
 associate of arts, 62, 63
 bachelor of arts, English/humanities, 67-69
 integrated language arts with adolescent to young adult licensure, 68, 69
 composition/foreign language labs, 66
 English sequence, 66
 minors, 69-71

programs offered, 66
 telephone number, 4, 66
 English Language and Linguistics Minor, 69, 70
 English Sequence, 66
 Enterprise Ohio Network, 181
 Environmental Engineering Technology, Bachelor of Science in, 168-170
 Environmental Science Certificate, 93
 Environmental Science Minor, 93, 94
 EOC, 184
 Explore Your Future, 182

F

Faculty, 60, 281-284
 Faculty Advising, 40
 Faculty Expectations and Responsibilities, 40, 41
 Family Educational Rights and Privacy Act, 26
 FAX Number, 4
 Federal Family Education Loan Program, 32
 Federal Parent Loan for Undergraduate Students (PLUS), 33
 Federal Pell Grant, 31, 32
 Federal PLUS Loan, 33
 Federal Stafford Loan, 32, 34
 Federal Subsidized Stafford Student Loan, 32
 Federal Supplemental Educational Opportunity Grant (SEOG), 32
 Federal Unsubsidized Stafford Loan, 32
 Federal Work Study, 33
 Fees, 29-31
 bad check, 29, 30
 campus view (room and board), 31
 carriage house (room and board), 31
 cedar house (room and board), 31
 communications fee, 31
 credit by arrangement, 29
 credit by examination, 30
 education field, 30
 full-time students, 29
 general, 30
 graduation, 30
 graduation re-petition, 30
 health science, 30
 ID card replacement, 30
 instructional, 29
 lab fees, 30
 late payment, 30, 31
 out-of-state, 29
 parking tag replacement, 30
 part-time students, 29
 private music lessons, 30
 refund of, 30, 31
 responsibility for, 30
 room and board, 31
 short term loan, 30
 technology, 29
 transcript, 30
 tuition, 21, 29
 university townhouse (room and board), 31
 Fellowships, 182
 Financial Aid, 31-35
 application procedure, 31
 eligibility requirements, 31, 32

employment, 33
 grants, 32
 loans, 32, 33
 notification and disbursement, 32
 probation, 34
 scholarships, 32
 standards of satisfactory progress for federal financial aid, 33-35
 student loans, 32, 33
 veterans, state programs, 33
 work study, 33
 Fine, Digital, and Performing Arts, Department of, 72-78
 academic advising, 61
 bachelor of fine arts, 73-78
 art education, 74-76
 ceramics, drawing, painting, and photography/imaging, 76
 studio arts, 76, 77
 visualist, 77, 78
 minors, 78
 programs offered, 73
 telephone number, 4, 73
 Fitness Development, Bachelor of Science in, 123, 124
 Free Application for Federal Student Aid (FAFSA), 31-33
 Fresh Start, 40
 Freshman Studies, 16

G

Game Room, 50
 GED, Applicants with, 15, 16, 21
 General Education Program, 55-57, 85, 104
 mathematics requirement, 85
 General Fee, 29
 Geography Minor, 104, 105
 Goals and Priorities of the University, 7
 Grade Appeals, 39
 Grade Point Average, 39
 Grade Reports, 41
 Grading/Awarding of Credit, 37
 Graduate Center, 43
 Graduation Fee, 30
 Graduation Re-Petition Fee, 30
 Graduation Requirements, 30, 41, 42
 fee, 30
 with honors, 42
 Graduation with Honors, 42
 Grants, 32
 Grants Management, 180

H

Health Clinic, 49
 Health Executives and Administrators Learning Society (HEALS), 135
 Health Insurance, 20, 30
 Health Management, Bachelor of Science, 134, 135
 Health Management, Minor, 142
 Health Science Fee, 30
 Health Sciences, Department of, 143-164
 accreditation, 8, 9, 145, 147, 151, 152, 154, 156, 158, 160, 161, 163

admission requirements, 15, 148-150
 appealing dismissal, 145
 associate of applied science, 148-164
 dental hygiene, 152, 153
 emergency medical technology, 154-156
 medical laboratory technology, 156, 157
 nursing, 150-152
 occupational therapy assistant, 158, 159
 physical therapist assistant, 159-161
 radiologic technology, 161, 162
 respiratory therapy, 162-164
 bachelor of science, 145-148
 nursing (RN-BSN), 145, 146
 occupational therapy, 146-148
 class scheduling, 144
 certification, 154, 156, 158, 162, 163
 deadline, application materials, 150
 emergency medical technology, 154-156
 hospital clinical sites, 144
 pass/no-credit policy, 144, 145
 programs offered, 144
 selective admission criteria, 144
 telephone number, 4, 144

Health Services, 49
 High School Students, 21-23
 History, Bachelor of Arts in, 97, 98
 History of the University, 6
 History Minor, 105
 Hodgden Travel Fund, 6
 Hold, Administrative, 37, 38
 Honors, Graduation, 42
 Honors Program, 42
 admission policy, 42
 requirements for graduation, 42
 Hospital Clinical Sites, 144
 Housing and Residence Life, 51
 Housing Fees (see Room and Board)
 Housing Policy, 51
 How to Reach us, 4

I

I-20 Form, 21
 ID Card Replacement Fee, 30
 Identification Cards, 30, 49, 50
 Improper Registration, 25
 Incomplete Grades, 37
 Individualized Studies Degree, Associate of, 64, 129
 Individualized Studies Degree, Bachelor of, 61, 62, 127, 128
 Industrial and Engineering Technologies, Department of, 165-175
 associate of applied science, 170-173
 computer aided design, 170, 171
 electromechanical engineering technology, 171, 172
 plastics engineering technology, 172, 173
 bachelor of science, 167-170
 computer engineering technology, 167, 168
 environmental engineering technology, 169, 170
 plastics engineering technology, 170
 CADD sequence, 171

certificate, 173, 174
 computer aided drafting and design, 173
 plastics engineering technology, 173
 web engineering technology, 173, 174
 industrial and engineering technology
 programs at Shawnee State, 166, 167
 minors, 174
 pass/no-credit policy, 167
 pre-engineering curriculum, 174, 175
 programs offered, 166
 robotics option, 174
 telephone number, 4, 166
 Instruction, Supplemental, 44
 Instructional Fee, 29
 Insurance, Student, 20, 30
 Integrated Language Arts with Adolescent
 to Young Adult Licensure, 68, 69, 114, 115
 Integrated Mathematics with Adolescent to
 Young Adult Licensure, 82, 83, 115
 Integrated Science with Adolescent to Young
 Adult Licensure, 91, 92, 118, 119
 Integrated Social Studies with Adolescent to
 Young Adult Licensure, 101-103, 115-117
 Intercollegiate Athletics, 47
 International Programs and Activities, 43, 44
 International Relations, Bachelor of Arts in,
 43, 98, 99
 International Students, 20, 21
 International Study Programs, 43
 Internet Cafe, 50
 Internship Guidelines, 40
 Internships, 77
 Intramural Sports, 47

J

James A. Rhodes Athletic Center, 6
 Job Placement, 48
 Journalism Minor, 70

L

Lab Fees, 30
 Late Payment, 30, 31
 Legal Assisting Technology, Associate of
 Applied Business in, 140, 141
 Legal Assisting (2 + 2), 136
 bachelor of arts in social science (2 + 2), 101
 bachelor of science in business
 administration (2 + 2), 136
 Library, 6, 44, 45
 Loans, 32, 33
 Lounges, 50

M

Mailing Address, 4
 Management Information Systems, 135, 136
 bachelor of science in, 136, 137
 Mathematical Sciences, Bachelor of Science in,
 80-82
 integrated mathematics with adolescent to
 young adult licensure, 82, 83
 Mathematical Sciences, Department of,
 79-85

academic advising, 61
 associate degrees, 63
 bachelor of science, mathematical sciences,
 80-84
 integrated mathematics with adolescent
 to young adult licensure, 82, 83
 bachelor of science, natural science, 83, 84
 mathematics, 83
 mathematics and science with middle
 childhood licensure, 83, 84
 general education mathematics requirement,
 85
 minor, 84
 programs offered, 80
 telephone number, 4
 Mathematical Sciences, Minor in, 84
 Mathematics Requirement, General Education,
 85
 Medical Laboratory Technology, 156, 157
 academic requirements, 157
 accreditation, 156
 admission requirements, 148-150, 157
 certification, 156
 employment opportunities, 156
 guidelines for appealing dismissal, 145
 health and physical ability requirements,
 157
 scholarships, 156, 157
 Michigan Test of English Language Proficiency
 (MTELP), 20
 Microsoft® IT Academy, 180
 Military Educational Experience, Credit for,
 39
 Middle Childhood Licensure,
 mathematics and science, 119
 Minors, 62, 69-71, 78, 84, 93, 94, 104-106,
 124, 142, 174
 American or British literature, 69
 biology, 93
 business administration, 142
 chemistry, 93
 computer aided design, 174
 economics, 104
 English language and linguistics, 69, 70
 environmental science, 93, 94
 geography, 104, 105
 health management, 142
 history, 105
 journalism, 70
 mathematical sciences, 84
 music, 78
 philosophy, 70
 plastics engineering technology, 174
 political science, 105
 professional writing, 70
 psychology, 105, 106
 sociology, 106
 sport coaching, 124
 teaching English to speakers of other
 languages, 70, 71
 theater, 78
 Miscellaneous Fees, 29, 30
 Mission Statement, University, 6, 7
 Multiage Intervention Specialist Licensure,
 113, 114
 Multiage Visual Arts Licensure, 119-121

Multicultural Student Services, 48, 49
 Music Minor, 78

N

National Association of Intercollegiate
 Athletics (N.A.I.A.), 6, 47
 Natural Science, Bachelor of Science in, 89-93
 earth, life, or physical science with
 adolescent to young adult licensure, 90,
 91
 integrated science with adolescent to young
 adult licensure, 91, 92
 mathematics, 83
 mathematics and science with middle
 childhood licensure, 83, 84, 92, 93
 Natural Sciences, Department of, 86-95
 academic advising, 61
 associate degree, 63
 bachelor of science, 87-93
 biology, 88
 chemistry, 88, 89
 natural science, 89-93
 earth, life, or physical science with
 adolescent to young adult licensure,
 90, 91
 integrated science with adolescent to
 young adult licensure, 91, 92
 mathematics and science with middle
 childhood licensure, 92, 93
 certificate, environmental science, 93
 minors, 93, 94
 premedical studies, 94, 95
 programs offered, 87
 telephone number, 4
 Non-Degree Students, 21-23
 Nursing, Associate of Applied Science in,
 150-152
 Nursing (RN-BSN), Bachelor of Science in,
 145, 146
 admission requirements, 145, 146
 program requirements, 146

O

Occupational Therapy, Bachelor of Science
 in, 146-148
 admission requirements, 147, 148
 accreditation, 147
 guidelines for appealing dismissal, 145
 Occupational Therapy Assistant, Associate
 of Applied Science in, 158, 159
 academic requirements, 158
 accreditation, 158
 admission requirements, 148-150
 clinical requirements, 158, 159
 guidelines for appealing dismissal, 145
 Office Administration Technology,
 Associate of Applied Business in, 141, 142
 Ohio Academic Competitions, 180, 181
 Ohio Appalachian Center for Higher
 Education, 6, 184
 Ohio Appalachian Educational Opportunity
 Center, 184
 Ohio Instructional Grant, 32

OhioLINK, 44, 45
 Online Learning, 181
 Open Enrollment, 74
 Orientation, 23, 26, 27
 for postsecondary options program students, 23
 Outreach Programs, 179-182
 Out-of-State Fees, 29

P

Painting, 76, 77
 Paramedic Program, 154-156
 Parent Loan for Undergraduates, 33
 Parking Tag Replacement Fee, 30
 Pass/No-Credit Policy, 38, 64, 144, 145, 166
 Pell Grant, 32
 Philosophy Minor, 70
 Physical Therapist Assistant, Associate of Applied Science in, 159-161
 accreditation, 160
 admission requirements, 148-150
 guidelines for appealing dismissal, 145
 Placement Testing, 26
 Planetarium, 6
 Plastics Engineering Technology, 170, 172, 173
 associate of applied science in, 172, 173
 bachelor of science in, 170
 certificate in, 173
 minor in, 174
 Political Science Minor, 105
 Postage Stamp Machines, 50
 Postsecondary Options Program, 21-23
 acceptance, notification, and reporting, 23
 application, 22, 23
 college credit (Option A), 22
 deadline, 23
 eligibility, 22
 high school and college credit (Option B), 22
 orientation and registration, 23
 other (non-Pop Program) high school students, 23
 program continuation, 22
 validation of credit, 23
 PRAXIS Series Tests, 110
 Pre-College Programs, 176-178
 Pre-engineering Curriculum, 174, 175
 Preferential Registration, 25
 Premedical Studies, 94, 95
 Preparation for Teacher Licensure, 64
 Prerequisites, 39, 186
 President, 3, 278
 President Emeritus, 278
 President's List, 38
 Previous Keyboard Training, 142
 Probation, Academic, 40
 Probation, Financial Aid, 34, 128, 129
 Professional Development, 182
 Professional Studies, College of, 126-175
 associate of individualized studies, 129
 bachelor of individualized studies, 128, 129
 business administration, department of, 130, 142
 faculty, 127, 128
 health sciences, department of, 143-164

industrial and engineering technologies, department of, 165-175
 programs offered, 127
 telephone number, 4, 127
 Professional Writing Minor, 70
 Professor Emeritus, 284
 Programs of Study, 54
 Psychology Minor, 105, 106
 Psychology, Bachelor of Arts in, 99, 100

R

Radiologic Technology, Associate of Applied Science in, 161, 162
 academic requirements, 161
 accreditation, 161
 admission requirements, 148-150
 guidelines for appealing dismissal, 145
 Reading Education Program, 121, 122
 Reciprocity, 29
 Refund of Fees, 30, 31
 Registration, 22, 24-27
 continuing or returning students, 25
 degree seeking freshmen, 25
 family educational rights and privacy act, 26
 high school students, 23
 improper, 25
 orientation, 26, 27
 placement testing, 26
 residency information, 25
 selective service, 25
 Repeating Coursework, 39
 Residency Information, 25
 Respiratory Therapy, Associate of Applied Science in, 162-164
 academic requirements, 163
 accreditation, 163
 admission requirements, 148-150, 163
 certification, 162, 163
 employment opportunities, 163
 guidelines for appealing dismissal, 145
 Responsibility for Fees, 30
 ROAD:MAP 2005, 184
 Robotics, 174
 Room and Board, 31

S

Satisfactory Academic Progress, 33-35
 Scholarships, 32, 156, 157
 School-to-Work, 181
 Science (See Natural Sciences, Department of)
 Science Degree, Associate of, 62, 63
 Secretarial (See Office Administration Technology)
 Selecting and Declaring a Major, 60
 Selective Admission Criteria, 144
 Selective Service Registration, 25, 32
 Senior Citizens, 21
 Senior Scholar Program, 21
 Short Term Loan, 30
 Social Sciences, Department of, 96-106
 academic advising, 61
 associate of arts, 62, 63
 bachelor of arts, 97-104
 history, 97, 98

integrated social studies with adolescent to young adult licensure, 101-103
 international relations, 98, 99
 psychology, 99, 100
 social science, 100, 101
 social sciences, legal assisting (2 + 2), 101
 sociology, 103, 104
 minors, 104-106
 programs offered, 97
 telephone number, 4, 97
 Social Science, 63, 64, 100, 101
 associate of arts in, 63, 64
 bachelor of arts in, 100, 101
 legal Assisting (2 + 2), 100, 101
 Sociology Minor, 106
 Sociology, Bachelor of Arts in, 103, 104
 Special Non-Degree Students, 21
 Sport Coaching, Minor, 124
 Sports Management, Bachelor of Science in Sports Studies, 124
 Sports Studies, Bachelor of Science in, 122-124
 application for admission, 122, 123
 athletic training, 122, 123
 fitness development, 123, 124
 sports management, 124
 Stafford Student Loan, 32-34
 Standards of Satisfactory Progress for Federal Financial Aid, 33-35
 State Policy on Articulation and Transfer, 17, 18
 Strategic Plan, 7, 8
 Student Activities, 49-52
 Student Emergency Loan Fund, 33
 Student Employment, 33
 Student Insurance, 20, 30
 Student Load, 29
 Student Loans, 32, 33
 Student Lounges, 50
 Student Success Center, 16, 26, 27, 41, 48, 49
 computer labs, 44
 disability services, 49
 multicultural student services, 48, 49
 orientation, 26, 27
 placement testing, 26
 supplemental instruction, 44
 tutoring, 44
 Student Support Services, 49
 Student Visa, 21
 Studio Arts, Bachelor of Fine Arts in, 76, 77
 Summer Honors Institute, 181
 Supplemental Education Opportunity Grant (SEOG), 32
 Supplemental Instruction, 44
 Suspension/Dismissal, Academic, 40, 41
 Suspension, Non-Attendance, 34

T

Talent Search, 177
 Targeted Industries Training Program, 181
 Teacher Education, Department of, 107-125
 academic advising, 61
 adolescent to young adult licensure, 114-119
 earth, life, or physical science, 117, 118
 integrated language arts, 114, 115
 integrated mathematics, 115

integrated science, 118, 119
 integrated social studies, 115-117
 application for admission, sports studies,
 122, 123
 associate of applied science, early childhood
 development, pre-K associate licensure,
 121
 bachelor of science, education, 111-114
 licensure in early childhood, 111, 112
 licensure in early childhood intervention
 specialist, 112
 licensure in middle childhood, 112, 113
 licensure in multiage intervention
 specialist, 113, 114
 bachelor of science, sports studies, 122-124
 application for admission, 122, 123
 athletic training, 122, 123
 fitness development, 123, 124
 sports management, 124
 certificate, deaf studies, 125
 children's learning center, 109
 eligibility criteria, 109, 110
 middle childhood licensure, mathematics
 and science, bachelor of science, natural
 science, 119
 minor, sport coaching, 124
 multiage visual arts licensure, bachelor of
 fine arts, 119-121
 portfolio requirement, 110
 postbaccalaureate, 110, 111
 PRAXIS series tests, 110
 preprofessional services, 109
 programs and licensure offered, 108
 reading education program, 121, 122
 Shawnee State graduates, 111
 teacher licensure programs, 108-121
 telephone number, 4, 108
 transfer, 110, 111
 Teaching English to Speakers of Other
 Languages Minor, 70, 71
 Tech Prep Ohio South Consortium, 181
 Technology Fee, 29
 Telephone Directory, 4
 Test of English as a Second Language
 (TOEFL), 20
 Theater Minor, 78
 Tours, Campus, 23
 Transcripts, 15, 16, 21, 30, 41
 fee, 30
 Transfer of Credit, 17-20
 appeal procedure, 18, 20
 Transfer Module, 17-20
 Transfer Students, 17-20
 Transient Students, 21
 TRIO Programs, 6
 Trustee Emeritus, 278
 Trustees, Staff, and Faculty, 277-284
 Tuition and Fees, 29-31, 186
 Tutoring, 44
 Twenty-First Century Community Learning
 Centers, 182

U

Undeclared Major/Undecided Student, 16
 University Center, 50

University Chronicle, 51, 52
 University Outreach Services, 179-182
 University Townhouse Rates (room and
 board), 31
 Upward Bound, 177, 178
 Upward Bound Math Science Center, 178

V

Vern Riffe Center for the Arts, 6, 73
 Veterans, 33
 Visitors to Class, 41
 Visualist Design and Interactive Media,
 Bachelor of Fine Arts in, 77, 78

W

Waller Conservatory, 87
 Web Engineering Technology, Certificate in,
 173, 174
 Welcome, 3
 Welcome Center, 50
 Withdrawal/Refund Dates, 30, 31
 Withdrawing from College, 41
 Work Study, 31, 33
 World Wide Web Address, 4

Survey

This catalog was prepared for your use by Shawnee State University's Printing & Graphic Services with input from many segments of the university community. Our aim is to provide a publication that is helpful to you—the student, faculty advisor, or counselor.

Please let us know how we're doing by completing the questionnaire below and returning it to: Shawnee State University, Printing & Graphic Services, 940 Second Street, Portsmouth, Ohio 45662-4344.

-
1. Did we leave any information out of the 2003-2005 catalog that would have helped you make your educational plans?

Yes No

If yes, what? _____

2. After using the catalog, were you left with questions that had to be answered in another way?

Yes No

If yes, what? _____

3. Did you find any contradictory or confusing information in the catalog?

Yes No

If yes, what? _____

4. How can we make the information concerning your degree or major more understandable?

5. What was **most** helpful about the 2003-2005 catalog?

(continued on next page)

